



**Republic of South Sudan
Ministry of General Education & Instruction
Secretariat of Examinations**

SOUTH SUDAN CERTIFICATE OF SECONDARY EDUCATION (SSCSE)

EXAMINATIONS PAST PAPERS QUESTION BOOKLET II

**MATHEMATICS AND SCIENCE SUBJECTS:
Mathematics, Physics, Chemistry, Biology, General Science,
Agriculture Principles and Practices.**

2010 - 2012

July 16, 2013

**Copyright: SOUTH SUDAN NATIONAL EXAMINATIONS COUNCIL
MINISTRY OF GENERAL EDUCATION & INSTRUCTION**

FOREWARD

The curriculum from which the South Sudan Certificate of Secondary Education (SSCSE) examinations were prepared to produce these past papers was launched in 2007, soon after the signing of the Comprehensive Peace Agreement (CPA) between Sudan and south Sudan in 2005.

Following the signing of the CPA and the subsequent formation of the government of Southern Sudan, Ministry of Education, Science and Technology (MOEST) as it was known, took it as a priority to devise the above-mentioned curriculum with the aim of improving the quality of education in South Sudan. The objectives of devising a separate curriculum included: to promote self identity of the peoples, to enhance the relevance of what is taught, to promote the diverse cultures and to ensure that the curriculum fulfils social, economical and political aspirations of the peoples South Sudan.

The syllabuses in Volume I of the curriculum, viz: English language, Christian Religious Education, History, Geography, Mathematics, Physics, Chemistry, Biology, General Science, Principles of Agriculture, Commerce, and Principles of Account were distributed to all schools in the ten states in 2008.

In 2009, Sample Question Papers on the above listed subjects were prepared, printed and distributed to schools as guides on what the schools, teachers and students studying these subjects expect in the (SSCSE) examinations.

This was carried out in an attempt to establish a viable system of SSCSE examinations in schools so that every school following the curriculum is aware of what the examinations require so that it can, work towards setting appropriate standards of performance for its students in the examinations which it can up hold.

Since 2010-2012, the Secretariat of Examinations of the Ministry of Education, Science and Technology/Ministry of General Education and Instruction has conducted the South Sudan Certificate of Secondary Education (SSCSE) Examinations with an increasing number of candidates. With the increasing candidatures, there is need to guide the incoming schools on what to expect by making available the past papers to effectively prepare their students for the examinations.

I therefore call, upon all stakeholders to make use of the past papers as guide to improve their students' learning and hence their achievements.

Additionally the past papers should also be used to determine the quality and relevance of the curriculum.

NB. The past papers are a publication of the South Sudan National Examination Council.

Mr. Rajab Sideria
Director General
Secretariat of Examinations
Ministry of General Education and Instruction



**GOVERNMENT OF SOUTHERN SUDAN
 MINISTRY OF EDUCATION
 EXAMINATIONS SECRETARIAT**



**SOUTHERN SUDAN CERTIFICATE OF SECONDARY EDUCATION (S.S.C.S.E)
 EXAMINATIONS**

Nov./Dec. 2010

**031/1 MATHEMATICS
 PAPER ONE**

NB: NAME (CAPITAL LETTERS):

INDEX NUMBER SIGNATURE.....

Must be written on all answer booklets used.

INSTRUCTIONS

Read the instructions carefully before answering any question.

1. The paper consists of Two Sections A and B. Candidates are required to answer all the ten questions in Section A (40 marks) and attempt at least five questions in Section B. (60 marks).
2. All answers to questions attempted must be written in the answer booklet provided; and rough work must be crossed out.
3. Mathematical tables with lists of formulae and squared papers will be provided.
4. Silent, non-programmable scientific calculators may be used.
5. State the degree of accuracy at the end of the answer to each question attempted using a calculator or tables; and indicate 'cal' for calculator, or 'Tab' for mathematical tables.

SECTION A (40 Marks)

Answer all questions in this section

1. Use mathematical tables only to evaluate

$$\frac{39.04 \times 0.04241}{0.0243 \times 2.6628} \quad (4 \text{ marks})$$

2. Solve the equation:

$$3^{2x+3} - 7(3^{x+1}) - 15 = 0 \quad (4 \text{ marks})$$

3. Evaluate

$$x^2 + 2x, \quad (4 \text{ marks})$$

If $x = \sqrt{5}$ and $\sqrt{5} = 2.2361$

4. A two-digit number is such that the sum of the ones and tens digits is 10. If the digit are reversed the new number formed exceed the original by 54. Find the number?

(4 marks)

5. Given $|z|$ and $\arg z = 120$, write down z .

(4 marks)

6. Find the inverse of $\begin{pmatrix} 2 & 3 \\ 1 & 4 \end{pmatrix}$

Hence determine the values of x and y in the equations:

$$2x + 3y = 8 \text{ and } x + 4y = 15$$

(4 marks)

7. Given that A is the set of all even numbers less than 20 and B is set of all triangle numbers less than 20, find $n(A \cap B)$.

(4 marks)

8. The length and the width of a rectangular garden were measured to the nearest centimeter and found to be 12.5 m and 8.4 m respectively. Find the maximum perimeter of the garden.

(4 marks)

9. Adut Paid 270 SDG for a Sofa set after getting a discount of 10%. The shopkeeper made a profit of 16% on the sale of the Sofa set. What profit would the shopkeeper have made if no discount was allowed?

(4 marks)

10. Two points P and Q have position vectors $6\mathbf{i} + 2\mathbf{j} - 4\mathbf{k}$ and $10\mathbf{i} + 10\mathbf{j} + 8\mathbf{k}$ respectively. Find the position vector of the point A if A divides PQ internally in the ratio 3:1.

(4 marks)

SECTION B (60 Marks)

Attempt only five questions in this section

11. The table below shows marks of 40 candidates in an examinations

MARKS	1-10	11-20	21-30	31-40	41-50	51-60	61-70	71-80	81-90	91-100
NUMBER OF CANDIDATES	2	2	3	9	12	5	2	3	1	1

- (a) Calculate the mean mark. (6 marks)
(b) Calculate the standard deviation. (6 marks)
12. (a) Draw the graph of the function $Y=x^3 + 4x^2 - x - 6$ for the range $-5 \leq x \leq 3$. (7 marks)
(b) Use your graph to solve the following:
(i) $x^3 + 4x^2 - x - 6 = 0$
(ii) $x^3 + 4x^2 - 5x - 21 = 0$ (5 marks)
13. Four towns A, B, C and D are such that town B is 120 km due east of town A. Town C is 160 km due north of town B. Town D is on a bearing of 330° from town A and on a bearing of 300° from town C.
(a) Using a ruler and compass only, show the position of towns A,B,C and D. (Take 1cm to represent 50 km).
(b) Determine (8 marks)
(i) the distance DA.
(ii) the bearing of town D from town B. (4 marks)
14. A train starts from rest from station D and accelerates uniformly for two(2) minutes reaching a speed of 60 km^{-1} . It maintains this speed for 10 minutes and then retards uniformly for 3 minutes to come to rest at station M.
Find:
(a) the distance DM in Km. (5 marks)
(b) the average speed of the train. (3 marks)
(c) the acceleration in ms^{-2} . (4 marks)
15. Solve the following trigonometric equations:
(a) $\sin 2x = \cos x$ for $0 \leq x \leq 360$ (4 marks)
(b) $\tan 3x = 2$ for $0 \leq x \leq 180$ (4 marks)
(c) $2\sin\left(x - \frac{\pi}{6}\right) = -\frac{\sqrt{3}}{\pi}$ for $0 \leq x \leq 2\pi$ (4 marks)

16. The displacement of a particle after t second is given by

$$S = 40t^3 - t^2 - 3t + 3.$$

Find the:

(4 marks)

(a) velocity of the particle when $t=2$.

(4 marks)

(b) acceleration of the particle when $t=3$.

(4 marks)

(c) Maximum displacement.

17. (a) The length of a room is 4m more than the width. The width is greater than 5m. The perimeter of the room is less than 36m. Given that the width of the room is b m, find the range of values of b satisfying the inequalities representing the given situation. **(6 marks)**
- (d) Majok is twice as old as her sister Kaya. Kaya's age is greater than 5 years. The sum of their ages is less than 30 years. Given that Kaya is x years old, form all the inequalities in x to represent the above information.
Hence find the ranges of values of x satisfying this inequalities. **(6 marks)**

END



**GOVERNMENT OF SOUTHERN SUDAN
MINISTRY OF EDUCATION
EXAMINATIONS SECRETARIAT**



**SOUTHERN SUDAN CERTIFICATE OF SECONDARY EDUCATION (S.S.C.S.E)
EXAMINATIONS**

Nov./Dec. 2010

**031/2 MATHEMATICS
PAPER TWO
3 HOURS**

NB: NAME (CAPITAL LETTERS):

INDEX NUMBER **SIGNATURE**.....
Must be written on all answer booklets used.

INSTRUCTIONS

Read the instructions carefully before answering any question.

1. The paper consists of Two Sections A and B. Candidates are required to answer all the ten questions in Section A (40 marks) and attempt at least five questions in Section B. (60 marks).
2. All answers to questions attempted must be written in answer booklet provided; and rough work must be crossed out.
3. Mathematical tables with lists of formulae and squared papers will be provided.
4. Silent, non-programmable scientific calculators may be used.
5. State the degree of accuracy at the end of the answer to each question attempted using a calculator or tables; and indicate 'cal' for calculator, or 'Tab' for mathematical tables.

SECTION A (40 Marks)

Answer all questions in this section

1. Given that $g = \sqrt{\frac{K}{P}}$, make K the subject. Hence find the value of K for $P=1$, $g=10$ and $L=5$.
(4 marks)
2. Using elimination method, find the values of x and y in the equations below:
$$\begin{aligned} 2x - y &= 10 \\ 3x + 2y &= 1 \end{aligned}$$
(4 marks)
3. Find the sum of the first 12 terms of the Arithmetic Progression (A.P.)
 $6 + 9 + 12 + \dots$ (4 marks)
4. Simplify: $\log_{10}40 + \log_{10}5 - \log_{10}2$ (4 marks)
5. Given that $f(x) = Px^2 + 7x$ and $f(4) = 44$, find the value of P.
Hence, evaluate $f(10)$ (4 marks)
6. Find the variance of the following scores 10, 21, 12, 14 and 18.
(4 marks)
7. Solve: $\frac{1}{2}(1-q) < \frac{1}{3}(2-q)$.
(4 marks)
8. Given that $\tan \theta = \frac{4}{3}$, find the value of $\sin \theta - \cos \theta$
(4 marks)
9. In the figure below, \overline{PQ} is a tangent to a circle with centre O. Angle $OQP = 30^\circ$ and $\overline{PQ} = 13$ cm.

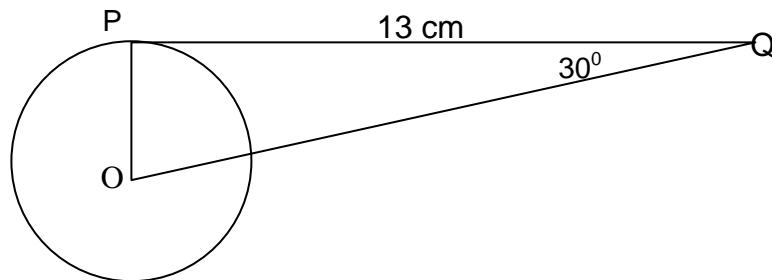

- (a) Find the length of OQ?
- (b) Find the radius of the circle?
(4 marks)

10. Given that p is inversely proportional to q and when $p=4$, $q=5$, find the value of p when $q=10$.

(4 marks)

SECTION B (60 Marks)

Attempt at least **Five** questions in this Section

11. In a certain teacher training workshop, a sample of 55 teachers was picked. It was found that 26 teachers eat fish (F), 31 eat beans (B) and 28 eat meat (M). 10 eat both fish and meat, 13 eat both meat and beans, and 9 eat both fish and beans. Each teacher eats at least one of the three types of food.

- (a) Represent the above information on a Venn diagram. (6 marks)
- (b) Find how many teachers eat all the three types of food. (2 marks)
- (c) What is the probability that a teacher picked at random eats only:
- (i) one type of food?
- (ii) at most two types of foods? (4 marks)

12. A plane flew from town A to town B 500 km apart, at an average speed of 50 km/hr on a bearing of 050° . It then changed its course to a bearing of 150° to town C, 350 km from B at the same speed of 50 km/hr. The plane developed mechanical problems hence delayed at town C for one hour and then continued with the same previous speed to town D 700 km from C on a bearing of 200° . The plane then traveled back from D direct to town A.

- (a) (i) By sketch drawing show the journey of the plane.
(ii) Using a scale of 1 cm: 50 Km draw accurately the journey of the plane.
- (b) Use your drawing to find the (6 marks)
- (i) distance of town A from D. (3 marks)
- (ii) bearing of A from D. (3 marks)
- (c) Determine the time taken by the plane to travel from town A to D and back to A. (3 marks)

13. (a) The vertices of a triangle are P(2, -1), Q(2, 2) and R(4, 2)

- (i) Find the images P^1 , Q^1 and R^1 of P, Q and R respectively, under the matrix transformation $\mathbf{M} = \begin{pmatrix} 2 & 1 \\ -1 & 2 \end{pmatrix}$
- (ii) Find the images P^{11} , Q^{11} and R^{11} of P^1 , Q^1 , and R^1 respectively, under the matrix transformation $\mathbf{N} = \begin{pmatrix} 2 & -3 \\ -1 & 1 \end{pmatrix}$ (6 marks)

- (b) Find a single matrix translation that would map P^{11} , Q^{11} and R^{11} back on to P, Q and R.

(6 marks)

14. In a certain school a teacher's salary includes the following tax-free allowances

TYPE OF ALLOWANCE	AMOUNT
Unmarried teacher	10 SDG
P.T.A	60 SDG
Class Teacher	10 SDG
Games and Sport Master/Mistress	15 SDG
Head of subject/department	20 SDG
Each child under 15 years	5 SDG
Each child over 15 years	3 SDG
Legally married teacher	15 SDG

Mr. Maring and Mr. Taban are teachers in this school. Mr. Maring is married with four children: one child under 15 years and three children over 15 years. He is also a class teacher and head of Mathematics department. Mr. Taban is single but has three children, two of whom are below 15 years and one above 15 years. He is also a class teacher and games and sport master.

Their gross incomes at the end of the month are each subjected to a "P.A.Y.E" (Pay As You Earn) which has the following rates: For the first 100 SDG taxable income the tax rate is 20%, while the rest is taxed at 15%.

At the end of the months Mr. Maring's gross income was 800 SDG and Mr. Taban's gross income was 600 SDG.

Calculate for each teacher the

- (a) total allowance. (4 marks)
 (b) taxable income. (4 marks)
 (c) tax paid. (4 marks)

15. Given that $Z_1 = 2 + 5i$ and $Z_2 = 3 + 2i$,

find

- (a) $|Z_1 + Z_2|$ (4 marks)
 (b) $\frac{Z_1}{Z_2}$ (4 marks)
 (c) $\text{Arg}(2Z_2 - Z_1)$ (4 marks)

16. The figure below shows a rectangular box of length 10 cm, width 8 cm, and height 6 cm. SB is a diagonal of the box and T is the mid point of SR.

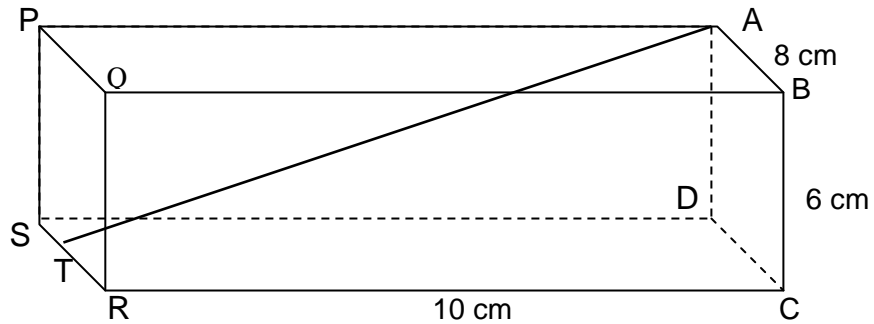

Calculate the

- (a) (i) length SB.
(ii) angle between SB and plane CDSR. (6 marks)
- (b) (i) length AT. (6 marks)
(ii) Angle ATD. (6 marks)

17. In the diagram below $\overrightarrow{QP} = \mathbf{p}$ and $\overrightarrow{OQ} = \mathbf{q}$. The points A and B are such that $\overrightarrow{PA} = \frac{1}{3}\overrightarrow{PQ}$ and $\overrightarrow{OB} = \frac{1}{3}\overrightarrow{OP}$.

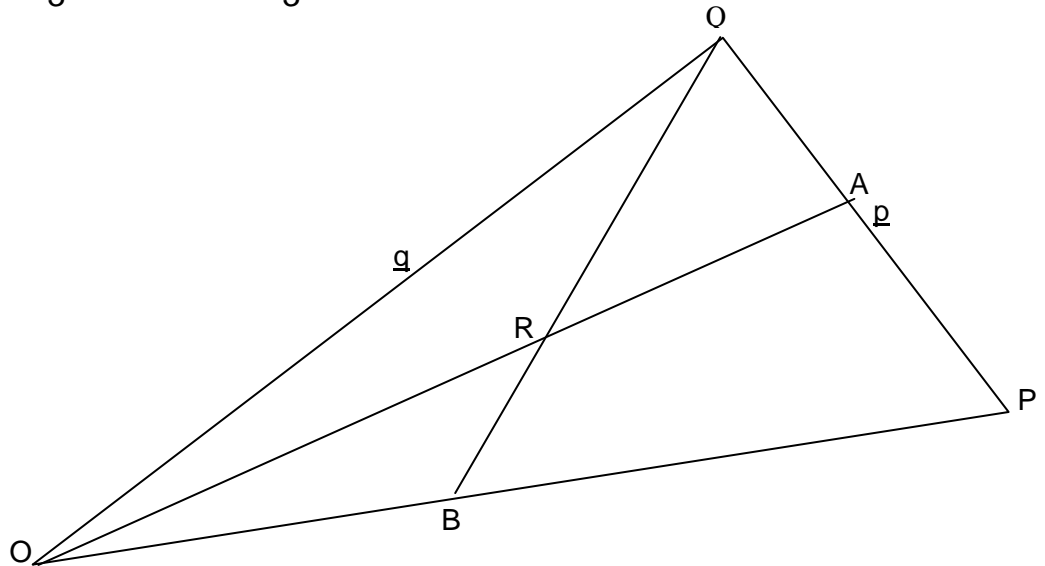

- (a) Express OA and QB in terms of \mathbf{p} and \mathbf{q} . (4marks)
(b) If $\overrightarrow{OR} = h\overrightarrow{OA}$ and $\overrightarrow{QR} = k\overrightarrow{QB}$

Express \overrightarrow{OR} in two ways and hence deduce

- (i) the values of h and k. (8 marks)
(ii) the vector OR in terms of \mathbf{p} and \mathbf{q} only.

END



**Republic of South Sudan
Ministry of General Education & Instruction
Secretariat of Examinations**

031/1
MATHEMATICS
Paper 1
3 hours

SOUTH SUDAN CERTIFICATE OF SECONDARY EDUCATION EXAMINATIONS

**MATHEMATICS
PAPER 1**

TIME: 3 HOURS

INSTRUCTIONS

Read the instructions carefully before answering any question

- 1. This paper consists of two (2) Sections (A and B). Answer all questions in Section A (40 marks) and at least five (5) questions in Section B (60 marks).*
- 2. All answers to questions attempted must be written in the answer booklet provided, and rough work must be crossed out.*
- 3. Mathematical tables with lists of formulae and squared papers will be provided.*
- 4. Silent non-programmable scientific calculators may be used.*
- 5. State the degree of accuracy at the end of the answer to each question attempted, using a calculator or tables; and indicate 'Cal' for calculator, or 'Tab' for Mathematical table.*

SECTION A (40 marks)

1. Without using a calculator or a mathematical table, workout:

(a) $\frac{1.25 \times 8^2}{6.25}$ [2 marks]

(b) $\frac{1.98 \times 0.04}{1.8}$ [2 marks]

2. If $\text{Log}_{10}2 = 0.30103$ and $\text{Log}_{10}3 = 0.47712$, without using mathematical tables or calculators, find:

(a) $\text{Log}_{10}^{1.5}$ [2 marks]

(b) Log_{10}^6 [2 marks]

3. Express $\frac{1}{3 - \sqrt{2}}$ in the form $a + b\sqrt{c}$ where a and b are fractions or integers. [4 marks]

4. $E(4, 3)$ is the midpoint of the line segment XY . Given that the co-ordinates of X are $(6,5)$, find the co-ordinates of Y . [4 marks]

5. If $\begin{pmatrix} 2 & 4 \\ -3 & 3 \end{pmatrix} + q \begin{pmatrix} 3 & 1 \\ 0 & n \end{pmatrix} = \begin{pmatrix} 8 & 6 \\ -3 & -1 \end{pmatrix}$, find the values of q and n . [4 marks]

6.

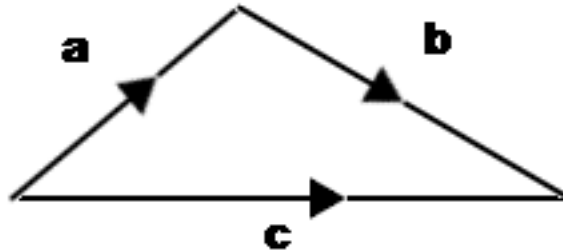

Fig. 1

Fig.1 above shows the relationship between vectors a , b and c .

If $a = 2i + 3j$ and $b = 5i - 2j$ where i and j are unit vectors, express c in terms of i and j .

[4 marks]

7. Given that the universal set $\xi = \{ a, b, c, d, e, f, g \}$ and $A = \{ a, c, e \}$ and $B = \{ b, e, g \}$, then find $A' \cap B'$. [4 marks]

8. Given that $\sin\theta = \frac{1}{2}$ and $90^\circ \leq \theta \leq 180^\circ$. Without using a calculator or a table, find $\cos\theta$ [4 marks]

9.

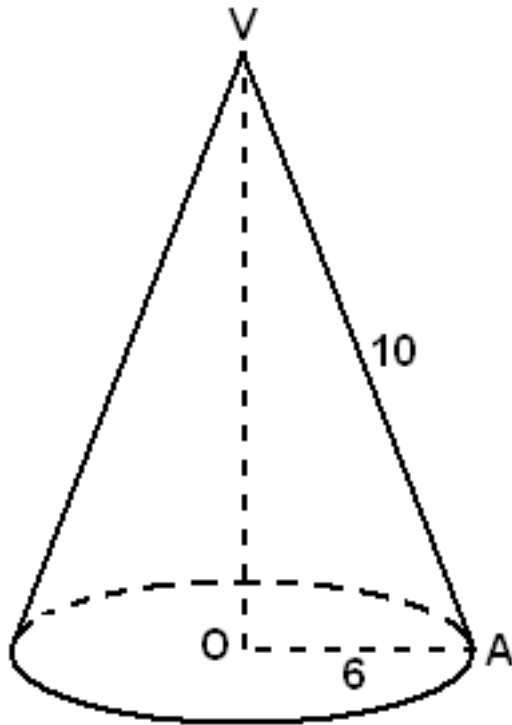

Fig. 2

Figure 2 above represents a right cone standing on a circle with center O and radius 6 cm. Slanting edge $\overline{VA} = 10$ cm. Find the volume of the cone, leaving your answer in terms of π . [4 marks]

10. Given that $Z_1 = 5 - 4i$ and $Z_2 = -4 + 6i$, find $|Z_1|$ and $|Z_2|$ [4 marks]

SECTION B

11. The table below shows the number of students who passed an end of year English promotional examination in terms of marks scored

a) Study the table and complete the missing details. [6 marks]

Scores	Class Mark (x)	Frequency(f)	fx
41 – 49			450
50 – 58		16	
59 – 67	63		1575
68 – 76			864
77 – 85		13	
86 – 94	90	4	360
		$\sum f = \dots\dots$	$\sum fx = \dots\dots$

- (a) (i) State the class interval of the scores. [1 marks]
(ii) Calculate the average score of the marks. [2 marks]
- (b) If all the above students were promoted and represent $\frac{4}{5}$ of the class, find the number of students who sat the examination. [3 marks]

12. (a) Given that $y = x^2 - 3x - 4$, copy and complete the table below. [3 marks]

x	-2	-1	0	1	2	3	4	5
x^2	4			1				25
$-3x$	6			-3		-9		
-4	-4	-4	-4	-4	-4	-4	-4	-4
y			-4					

- (c) Using an appropriate scales, draw the graph of the function $y = x^2 - 3x - 4$ [7 marks]
(c) Use your graph to determine the roots of the equation $x^2 - 3x - 4 = 0$ [2 marks]

13. A plane flies from airstrip K due north for 350 km to airstrip R. It then flies on a bearing of 295° for 250 km to airstrip N. From there it flies on a bearing of 090° for 500 km to another airstrip M.

- a) Draw a sketch diagram to show the route of the plane. Hence draw an accurate diagram using a scale of 1 cm to represent 50 km. [6 marks]
b) From your diagram, find the distance and bearing of airstrip K from M. [2 marks]

c) If the plane flies back to airstrip K by the direct route, and it travels at an average speed of 250 km h^{-1} , find the time (in hours) taken for the whole journey. [4 marks]

14. a) In fig. 3 below, ABC is an isosceles right-angled triangle. The shaded region is bounded by two circular arcs. The outer arc is a semi-circle with AC as diameter and the inner arc is a quarter of the circle with center B.

Find the area of the shaded region [8 marks]

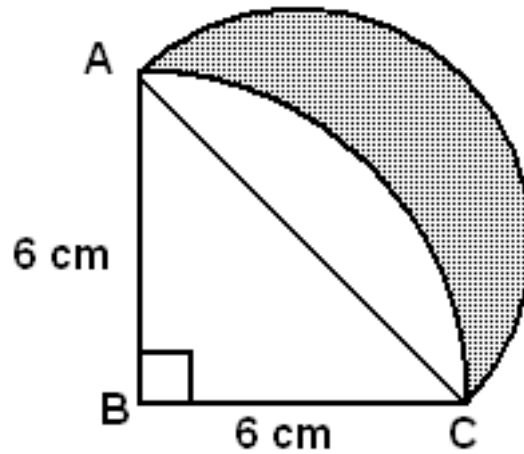

Fig. 3

b). Using matrix methods, solve the pair of simultaneous equations below [4 marks]

- i. $2x - y = 1$
- ii. $3x + 2y = 12$

15. A wholesaler wishes to transport 870 crates of soda from a factory. He has a lorry which can carry 150 crates at a time and a pick-up truck which can carry 60 crates at a time. The cost of each journey for the lorry is SSP 250 and for the pick-up SSP 200. The pick-up makes more journeys than the lorry because it travels faster. The amount of money available for transporting the soda is SSP 2200.

- a) Write down five inequalities representing the above information. [2 marks]
- b) Plot a graph for the inequalities, shading out the unwanted regions. [8 marks]
- c) How many journeys should the lorry and the pick-up make so as to keep the transport cost as low as possible? [2 marks]

16. (a) Differentiate and then simplify the expression $y = (x^2 - 3)(x + 1)^2$ [6 marks]

(b) Workout $\int_{-1}^2 \frac{x}{\sqrt{(x^2+3)}} dx$ [6 marks]

17. Vehicle A left Juba town at 9 a.m. and traveled towards Rumbek, a distance of 40 km, at an average speed of 15 km/h. At 10 a.m. vehicle B left Yei on a journey towards Juba at a speed of 25 km/h.

Determine:

(a) At what time did they meet? [8 marks]

(b) How far from Juba was vehicle B when they met? [2 marks]

(c) If the two vehicles took 10 minutes at the meeting point and then vehicle A continued towards Rumbek at an average speed of 12 km/hr, find the time at which it arrived at Rumbek. [2 marks]

THE END



Republic of South Sudan
Ministry of General Education & Instruction
Secretariat of Examinations

031/2
MATHEMATICS
Paper 2
3 hours

SOUTH SUDAN CERTIFICATE OF SECONDARY EDUCATION EXAMINATIONS

MATHEMATICS
PAPER 2

TIME: 3 HOURS

INSTRUCTIONS

Read the instructions carefully before answering any question

- 1. This paper consists of two (2) Sections (A and B). Answer all questions in Section A (40 marks) and at least five (5) questions in Section B (60 marks).*
- 2. All answers to questions attempted must be written in the answer booklet provided, and rough work must be crossed out.*
- 3. Mathematical tables with lists of formulae and squared papers will be provided.*
- 4. Silent non-programmable scientific calculators may be used.*
- 5. State the degree of accuracy at the end of the answer to each question attempted, using a calculator or tables; and indicate 'Cal' for calculator, or 'Tab' for Mathematical table.*

SECTION A (40 marks)

1. Given that $\frac{23.6}{100,000} = 2.36 \times 10^y$, Solve for y [4 marks]

2.

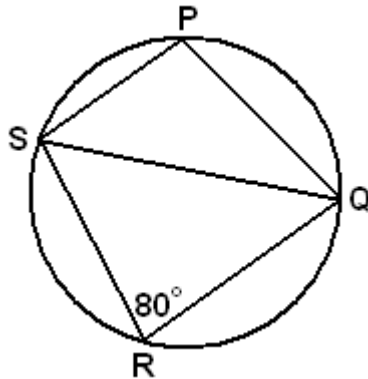

Fig. 1

In fig. 1 above, PQRS is a quadrilateral whose vertices lie on a circle. Angle SRQ = 80°. Find the sum $\angle PSQ + \angle PQS$. [4 marks]

3. If y is directly proportional to x^3 , copy and complete the table below [4 marks]

x	2	6	8	-	10
y	0.1	-	-	12.5	

4. Given that $f(x) = x^2$ and $g(x) = (x + 1)$, determine $f[g(x)]$ and hence find $f[g(-3)]$. [4 marks]

5. Evaluate: $\frac{(5^5 \times 5^4 \times 2^{12})^2}{(5^6 \times 2^7 \times 2^2)}$ [4 marks]

6. A fair die is tossed once. Find the probability that:

- (i) the die shows a number greater than 3 [2 marks]
 (ii) an odd or even number less than 4 shows up [2 marks]

7. Using Pascal's triangle, evaluate $(11.03)^3$ correct to 3 decimal places [4 marks]

8. Given the equation, $r = \sqrt{x^2 + y^2}$, make x the subject. [4 marks]

9. A rectangular tank has a hole in it so that 11cm^3 of water leaks out every 5 seconds.

- (a) Calculate the number of liters of water lost from the tank every hour. [2 marks]
- (b) The water which leaks out is collected in a cylindrical tank which has a base radius and height of 30cm each. Calculate how long it takes to fill the tank. [2 marks]
10. Solve for x in the equation $3x^2 = 5x + 4$. [4 marks]

SECTION B (60 marks)

Answer any five questions in this section.

11. In a class of 60 students, each student takes at least one of the subjects: Agriculture (A), Biology (B) and Chemistry (C). Twelve students take only Agriculture, seven students take only Biology and eleven students take only Chemistry. Six students take all the three subjects.

Given that: $n(A' \cap B \cap C) + n(A \cap B' \cap C) = n(A \cap B \cap C')$

Find the:

- (a) $n(A' \cap B \cap C)$ and $n(A \cap B' \cap C)$ [6 marks]
- (b) Number of students who take Agriculture [2 marks]
- (c) Probability that a student picked at random from the class takes Chemistry [2 marks]
- (d) Probability that a student picked at random from the class takes both Agriculture and Biology [2 marks]
12. (a) **H** represents the transformation "half-turn about the origin".
- (i) Write the 2x2 matrix for the transformation **H**. [1 mark]
- (ii) Describe \mathbf{H}^{-1} the inverse of transformation **H**. [1 mark]
- (iii) Find the single 2x2 matrix for the matrix product $\mathbf{H}^{-1}\mathbf{H}$. [2 marks]
- (b) The 2x2 matrix for the transformation K is $\begin{pmatrix} 0 & 2 \\ -2 & 0 \end{pmatrix}$.
- (i) Given A(2, 1), B(4, 1) and C(4, -1), find the coordinates of A', B' and C', the images of A, B and C under transformation K. [5 marks]
- (ii) Plot on the same graph ΔABC and $\Delta A'B'C'$. [3 marks]

13. (a) Given the function $y = 2x^2 - 8x + 5$
- (i) Find the coordinates of the turning point of the function. [3 marks]
- (ii) Determine if the turning point is a maximum or a minimum. [3 marks]
- (b) The function $y = -x^2 + 4x - 3$ intersects the x-axis at the points $x = 1$ and $x = 3$. Determine the area between the curve and the x-axis between $x = 1$ and $x = 3$. [6 marks]

11. In a certain country, income tax is levied as follows:

- A person's monthly gross income has a certain allowance deducted from it before it is subjected to taxation
- These allowances are as follows:

Married man	SDG	1800
Unmarried man	SDG	1200
Each child below 11 years	SDG	500
Each child above 11 years but below 18 years	SDG	700
Insurance premium	SDG	1200

Ladu earns SDG 665,000. He is married with three children aged between 11 and 18 years and two below 11 years. Given that he is insured and has claimed transport allowance of SDG 1700, calculate

- (a) Calculate Ladu's taxable income [7 marks]
- (b) the tax he pays under the income tax rate below [3 marks]

Taxable income (SDG)	Tax rate (%)
100,000 and less than 200,000	10
200,000 and less than 300,000	20
300,000 and less than 400,000	30
400,000 and less than 500,000	40
500,000 and above	55

- (c) Express Ladu's taxable income as a percentage of his gross income [2 marks]

15. Given that $Z_1 = (3 - 2i)$, $Z_2 = (-2 + 4i)$

(a) Workout: [2 marks]

(i) $Z_1 + Z_2$

(ii) $Z_1 - Z_2$

(b) Represent the following on Argand diagram: [2 marks]

(i) $Z_1 + Z_2$

(ii) $Z_1 - Z_2$

(c) Find the modulus and arguments of :

[8 marks]

(i) Z_1

(ii) Z_2

(iii) $Z_1 + Z_2$

(iv) $Z_1 - Z_2$

16. Using a ruler, pencil and pair of compasses **only**,

(i) construct triangle ABC such that $AB = 8$, angle $ABC = 60^\circ$ and angle $BAC = 45^\circ$,

[4 marks]

(ii) construct the perpendicular from C onto AB to meet it at D. Measure and record the length CD.

[3 marks]

(iii) draw a circle circumscribing triangle ABC. Measure and record its radius.

[3 marks]

(iv) find the area of triangle ABC.

[2 marks]

17. OAB is a triangle. $OA = a$, $OB = b$ points C and E are points on lines OA and AB such that they divide the OA and AB in the ratios 1:2 and 3:1 respectively. Point D lies on OE such that $OD = 2DE$

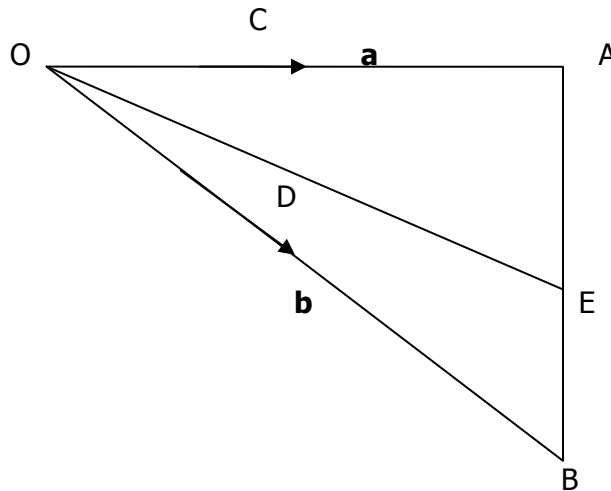

(a) Find the vectors \vec{AB} , \vec{OE} , \vec{C} and \vec{CB} in terms of \mathbf{a} and \mathbf{b} .

[8 marks]

(b) Show that C, D and B are collinear.

[4 marks]

THE END



**Republic of South Sudan
Ministry of General Education & Instruction
Secretariat of Examinations**

031/1
Mathematics
Paper 1
3 hours

SOUTH SUDAN CERTIFICATE OF SECONDARY EDUCATION EXAMINATIONS

**NOV/DEC, 2012
MATHEMATICS
PAPER ONE**

TIME: 3 HOURS

INSTRUCTIONS

Read the instructions carefully before answering any question.

1. This paper consists of two (2) sections: Section A and Section B. Answer all questions in Section A (40 marks) and at least five (5) questions in Section B (60 marks).
2. All answers to questions attempted must be written in the answer booklet provided, and rough work must be crossed out.
3. Mathematical tables with lists of formulae and squared papers will be provided.
4. Silent, non-programmable scientific calculators may be used.
5. State the degree of accuracy at the end of each answer. In answers where a calculator or tables have been used, write CAL to indicate use of a calculator and TAB to indicate use of mathematical tables.

Section A : (40 marks)

Answer all the questions in this section.

1. Without using tables or calculator, evaluate:

(i) $\log 50 + \log 40 - \log 200$

(ii) $\frac{(7550)^2 - (2450)^2}{5100}$ (4 marks)

2. (a) Make G the subject of the formula: $T = 2\pi\sqrt{\frac{H}{G}}$

(b) Express the recurring decimal **0.15909090...** as a fraction in its simplest form. (4 marks)

3. (a) Find the numbers represented by the letters x and y in:

$$\begin{pmatrix} 2 & 0 \\ 3 & 4 \end{pmatrix} \begin{pmatrix} x \\ y \end{pmatrix} = \begin{pmatrix} 4 \\ 18 \end{pmatrix}$$

(b) Given that $OP = \begin{pmatrix} 3 \\ -2 \end{pmatrix}$, $QP = \begin{pmatrix} -4 \\ -1 \end{pmatrix}$, $QR = \begin{pmatrix} -1 \\ 5 \end{pmatrix}$

If **O** is the origin, find the coordinates of point R. (4 marks)

4. (a) A radio was sold for 2250 SSP making a profit of 25%. Calculate the cost price of the radio.

(b) Using mathematical tables, evaluate the cube root of **0.02795** (4 marks)

5. (a) Solve for x:

$$3^x + 3^2 = 90$$
 (2 marks)

(b) Given the matrices: $A = \begin{pmatrix} 2 \\ 1 \end{pmatrix}$, $B = (3 \ -5)$

Find the products:

- (i) AB
 - (ii) BA
- (2 marks)

6. (a) Find the point of intersection of the lines given by:

$$y = -2x + 1 \text{ and } y = \frac{x}{2} + 6 \quad (2 \text{ marks})$$

- (b) A bag contains 5 red marbles and 3 blue marbles all of equal size. A marble is selected at random from the bag and not replaced. A second marble is selected at random.

What is the probability of getting a red marble followed by a blue marble?

(2 marks)

7. Given that $z_1 = 4 + 5i$ and $z_2 = 1 - i$ are complex numbers

Find

(i) the product $(z_1) \times (z_2)$ (2 marks)

(ii) the quotient $\frac{z_1}{z_2}$ (2 marks)

8. The first term of a geometric progression (G.P.) is 36.
The sum of the first three terms of the G.P. is 27.

Find the common ratio.

(4 marks)

9. In Figure 1, $\overline{XY} = 5\sqrt{3}$ is a tangent to the circle centre O.
Angle $XYO = 30^\circ$.

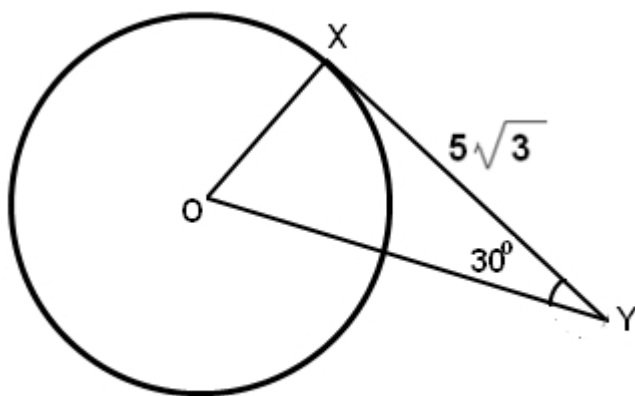

Figure 1

Find:

- (i) length of \overline{OY}
(2 marks)
- (ii) the radius of the circle.
(2 marks)

10. Show that the points $A(3, -1)$, $B(-1, 4)$ and $C(-9, 14)$ are collinear. (4 marks)

Section B: (60 marks)

Answer any FIVE questions from this section.

11. The table below shows the points scored by South Sudan basketball team over one season.

Score	Number of matches (f_i)	Cumulative frequency	Class midpoint (X_i)	$(f_i)(X_i)$
31 – 40	2			
41 – 50	4			
51 – 60	18			
61 – 70	19			
71 – 80	28			
81 – 90	14			
91 – 100	11			
101 – 110	4			

- (a) Copy and complete the table to show the missing information. (2 marks)
- (b) By calculation, estimate the mean score for this season. (2 marks)
- (c) Draw a cumulative frequency curve (Ogive) for this data. (3 marks)
- (d) Use your graph to estimate
- (i) the median score. (2 mark)
- (ii) the upper and lower quartile scores. (2 marks)
- (e) Calculate the inter-quartile range. (1 mark)
12. In Marialbai S.S, all 100 students take English. 46 students take mathematics, 40 take chemistry, 60 take biology. 20 students take math and chemistry, 10 take chemistry and biology, while 30 take math and biology. The number that take none of these three subjects is two and a half ($2\frac{1}{2}$) of the number taking all the four subjects.
- (a) Draw a suitable well-labelled Venn diagram for the above information. (4 marks)
- (b) Hence, determine:
- (i) the number that take all the subjects. (4 marks)
- (ii) the number that take one subject. (4 marks)

13. The displacement, S (centimeters) of a particle, of a point is connected to the time t (seconds) by the equation:

$$S = \frac{t^3}{3} - \frac{9t^2}{2} + 18t$$

- (a) Calculate the displacement when $t = 1$ s. (2 marks)
- (b) Find formulas in terms of t for:
- (i) Velocity of the particle. (3 marks)
- (ii) Acceleration of the particle. (1 mark)
- (c) Find the times, t , when the particle is at rest. (4 marks)
- (d) Determine the rate at which the particle is accelerating or decelerating at $t = 5$ s. Clearly state if your value is an acceleration or a deceleration. (2 marks)
14. (a) $x^2 - 10x + y^2 + 4y + 4 = 0$ is an equation of a circle.
- (i) Show that the point $(5, 3)$ lies on the circle. (1 mark)
- (ii) Write the equation in the form $(x - a)^2 + (y - b)^2 = r^2$ (3 marks)
- (iii) State the coordinates of the center and the radius of the circle. (2 marks)
- (b) Points A and B are 8 cm apart.
Points P and Q are at a distance of 5 cm from both A and B
- (i) Draw an accurate diagram of the figure $APBQ$, labelling the points A, P, B and Q . (3 marks)
- (ii) Calculate the area of the quadrilateral $APBQ$. (3 marks)
15. Using a ruler, pencil and pair of compasses **only**,
- (i) construct triangle ABC such that $AB = 8$, angle $ABC = 60^\circ$ and angle $BAC = 45^\circ$, [4 marks]
- (ii) construct the perpendicular from C onto AB to meet it at D . Measure and record the length CD . [3 marks]
- (iii) draw a circle circumscribing triangle ABC . Measure and record its radius. [3 marks]
- (iv) find the area of triangle ABC . [2 marks]
16. (a) Solve the following inequality:

$$\frac{3}{2}x + 2 \geq 2x \quad (3 \text{ marks})$$

- (b) (i) By shading out unwanted points, show the region which contains the set of points represented by the following inequalities:

$$x > 0, y > 0, 2x + y \geq 6, 2x + y \leq 10 \quad (6 \text{ marks})$$

- (ii) Calculate the area of the unshaded region. (3 marks)

17. Figure 2 shows a right pyramid standing on a square base. The edge of the base is 4 cm. The slanting edges of the pyramid are 7 cm as shown in the figure.

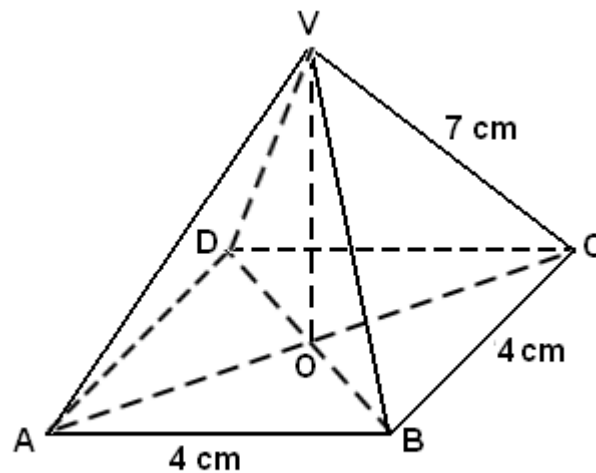

Figure 2

- (a) Calculate the total surface area of the pyramid.
- (b) Calculate \overline{VO} , the height of the pyramid.
- (c) Using the formula: $V = \frac{1}{3} \times (\text{height}) \times (\text{area of base})$
calculate the volume of the pyramid.
- (d) A second pyramid similar in shape to the one shown in Fig 2 has a base of area 100 cm^2 .
Calculate the volume of the second pyramid.

THE END



**Republic of South Sudan
Ministry of General Education & Instruction
Secretariat of Examinations**

**031/2
Mathematics
Paper 2
3 hours**

SOUTH SUDAN CERTIFICATE OF SECONDARY EDUCATION EXAMINATIONS

**NOV/DEC, 2012
MATHEMATICS
PAPER TWO**

TIME: 3 HOURS

INSTRUCTIONS

- 1. This paper consists of two (2) sections: Section A and Section B. Answer all questions in Section A (40 marks) and at least five (5) questions in Section B (60 marks).*
- 2. All answers to questions attempted must be written in the answer booklet provided, and rough work must be crossed out.*
- 3. Mathematical tables with lists of formulae and squared papers will be provided.*
- 4. Silent, non-programmable scientific calculators may be used.*
- 5. State the degree of accuracy at the end of each answer. In answers where a calculator or tables have been used, write CAL to indicate use of a calculator and TAB to indicate use of mathematical tables.*

Section A: (40 marks)

Answer all the questions in this section.

- Solve for x in the equation $3x^2 = 5x + 4$.
- Given that $a^2 - b^2 = 63$ and $a + b = 21$, find the values of a and b .
- Given vector $a = \begin{pmatrix} 9 \\ -12 \end{pmatrix}$, find $|a|$, the length of vector a .
 - Given that vector $b = \begin{pmatrix} 10\sqrt{2} \\ x \end{pmatrix}$ is such that $|b| = |a|$, find the value of x .
- Express $\frac{1}{3 - \sqrt{2}}$ in the form $a + b\sqrt{c}$ where a and b are fractions or integers.
 - If $234_{\text{five}} = X_{\text{ten}}$, find the value of X .
- Figure 1 is a hexagon with five interior angles of α° each and one exterior angle of α° . (The diagram is **not** drawn to scale.)

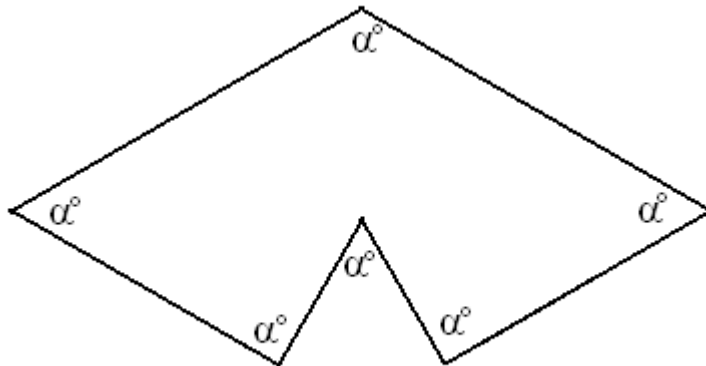

Figure 1

Find the value of α .

6. Solve the simultaneous equations:

$$3x + 4y = 5$$

$$2x + 3y = 3$$

7. The table below shows number of children per family in a village.

Number of children	0	1	2	3	4	5
Number of families	1	3	3	4	2	1

(i) Determine the number of children in the village.

(ii) Calculate the average number of children per family.

8.

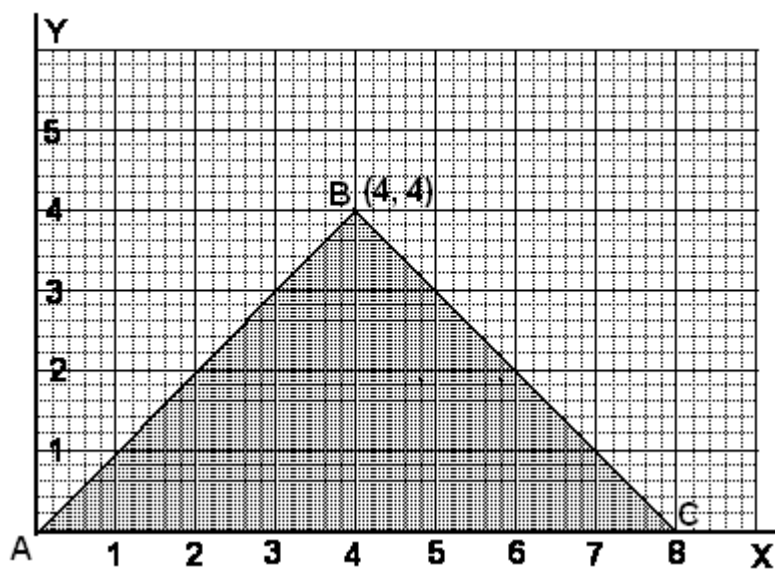
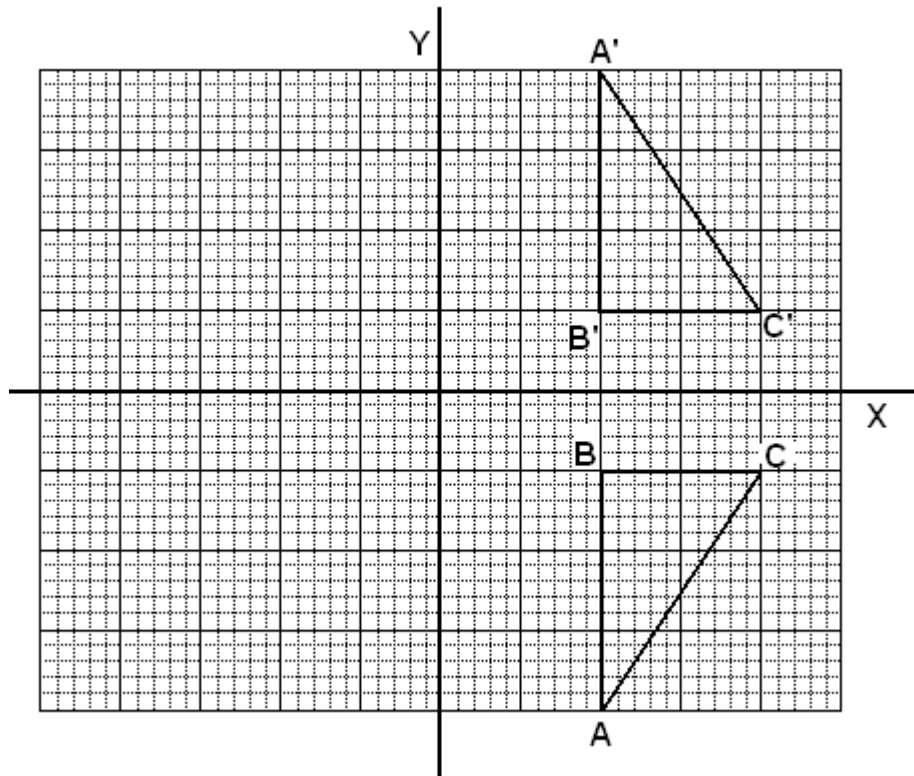

Figure 2

Write three inequalities to describe the points on the interior of triangle ABC as shown in Figure 2.

9. Show that the complex number $2 + 3i$ is a root of the equation $x^2 - 4x + 13 = 0$.

10.



- (i) Describe fully the transformation that maps $\triangle ABC$ onto $\triangle A'B'C'$
- (ii) Find the 2×2 matrix for the transformation in part (i).

Section B: 60 marks

Attempt five questions from this section. All questions carry equal marks.

11. A television valued at \$440 is to be imported to South Sudan. Customs duty is assessed at 25% of the declared value and value added tax (V.A.T.) is assessed at 10% of declared value plus customs duty.
- (a) Calculate the customs duty which is payable in dollars (\$). (2 mks)
 - (b) Calculate the V.A.T., which is payable in South Sudanese pounds (SSP) at an official rate of \$1 = SSP 2.60. (4 mks)
 - (c) A businesswoman imported the television. She now wishes to sell it at a profit of 20%. Given that the market value of SSP is about SSP 450 to \$100
 - (i) convert her dollar expenditures into SSP at the market rate. (2 mks)
 - (ii) calculate her total cost price of the television in SSP. (2 mks)
 - (iii) calculate the price in SSP at which she should sell the television. (2 mks)

12. (a) Copy and complete the following table for the function $y = x^2 - 4x + 1$

x	-2	-1	0	1	2	3	4	5	6
x^2	4		0			9		25	36
$-4x$	8		0	-4			-16	-20	-24
1	1	1	1	1	1	1	1	1	1
y	13		1	-2			1	6	

- (b) Choosing suitable scales, draw the graph of $y = x^2 - 4x + 1$ for $-2 \leq x \leq 6$. (5 mks)
 - (c) Use your graph to estimate roots of the equation $x^2 - 4x + 1 = 0$ (2 mks)
 - (d) (i) Draw a tangent to the curve at the point (5, 6). (2 mks)
 - (ii) Find the slope of the tangent line at (5, 6) (2 mks)
 - (iii) State whether the function is increasing or decreasing at the point (5, 6) (1 mk)
13. (a) If two cards are drawn from a well-shuffled pack of 52 playing cards, what is the probability that
- (i) both cards are Aces (A)? (3 mks)

(ii) neither card is an Ace? (3 mks)

(iii) at least one of the cards is an A? (3 mks)

(b) A committee of two members is to be elected from a group of five eligible members. How many different committees can be formed? (3 mks)

14. (a) The diagram below is a sketch of the function $y = 5 + 4x - x^2$

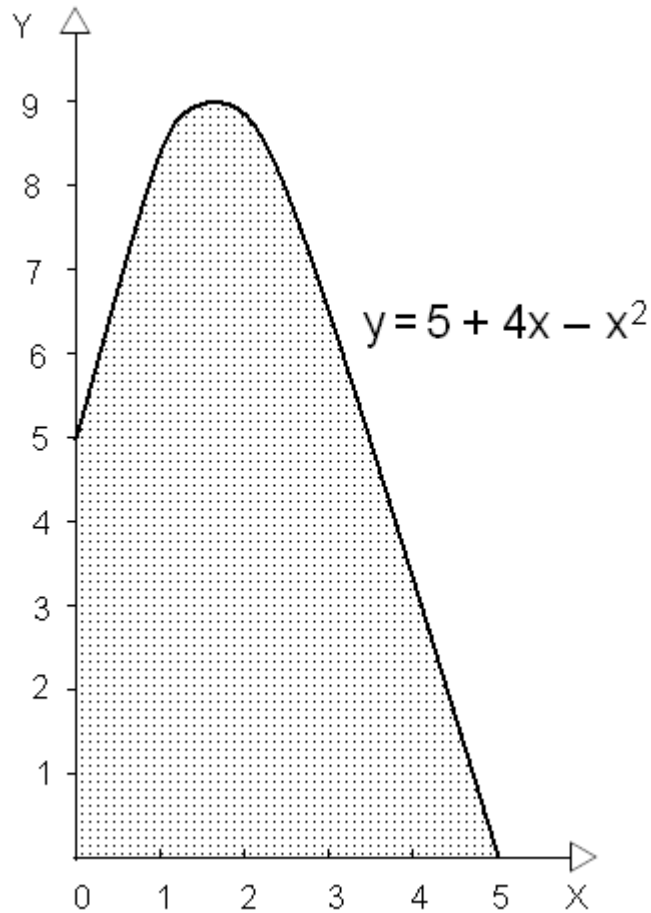

Use the trapezium method, with five equal intervals along the x-axis to estimate the area under the curve for $0 \leq x \leq 5$. (5 mks)

(b) Determine the exact area under the curve by evaluating the

definite integral $\int_0^5 (5 + 4x - x^2) dx$ (5 mks)

(c) Calculate the percentage error associated with your estimate in (a) as compared with the exact value in (b). (2 mks)

15. $z = -2\sqrt{3} + 2i$ is a complex number.

- (a) (i) Show the location of this complex number on an Argand diagram. Indicate where $|z|$ (the modulus of z) and $\arg(z)$ (the argument of z) can be found on the diagram. (4 mks)
- (ii) Calculate the value of $|z|$, the modulus of the complex number. (2 mks)
- (iii) Calculate $\arg(z)$, the principle argument of the complex number. (2 mks)
- (b) A complex number written in the form $a + bi$ is said to be in rectangular form. The same number can be written in trigonometric form as $r(\cos\theta + i \sin\theta)$ where r is the modulus and θ is the argument of the complex number.

(i) Write the complex number z in trigonometric form. (2 mks)

(ii) Making use of the double-angle formulas (2 mks)

$$2 \sin\theta \cos\theta = \sin(2\theta) \quad \text{and} \quad \cos^2\theta - \sin^2\theta = \cos(2\theta)$$

show that $z = [2(\cos 75^\circ + i \sin 75^\circ)]^2$, that is, $2(\cos 75^\circ + i \sin 75^\circ)$ is a square root of z .

16.

Row	Used for	Pascal's Triangle							Sum
1 st	$(a + b)^0$	1							1
2 nd	$(a + b)^1$	1		1					2
3 rd	$(a + b)^2$	1	2	1					4
4 th	$(a + b)^3$	1	3	3	1				8
5 th	$(a + b)^4$	1	4	6	4	1			16
6 th	$(a + b)^5$	1	5	10	10	5	1		32
7 th	$(a + b)^6$	1	6	15	20	15	6	1	64

The diagram above shows the first seven rows of Pascal's Triangle. The column on the right shows the sum of the numbers in each row across the triangle.

- (a) What is the coefficient of the term containing a^3b^3 in the expansion of $(a + b)^6$? (2 mks)
- (b) (i) What is the sum of the numbers in the 10th row of Pascal's Triangle? (1 mk)
- (ii) Write a formula in terms of n for the sum of the numbers in the n^{th} row of Pascal's Triangle. (2 mks)
- (c) (i) Write out the expansion of $(2 - 0.1)^4$ (4 mks)



**GOVERNMENT OF SOUTHERN SUDAN
MINISTRY OF EDUCATION
EXAMINATIONS SECRETARIAT**



**SOUTHERN SUDAN CERTIFICATE OF SECONDARY EDUCATION (S.S.C.S.E)
EXAMINATIONS**

Nov./Dec. 2010

**041/1 PHYSICS
PAPER ONE
3 HOURS**

NAME (CAPITAL LETTERS):

INDEX NUMBER **SIGNATURE**.....

INSTRUCTIONS

Read the instructions carefully before answering any question.

1. This paper consist of two Section A and B.
SECTION A (1 – 40) multiple choice question (40 marks)
SECTION B (41 – 50) structured questions (60 marks)
2. Candidates are required to answer all questions on the question paper.
3. Answers to section A are to be written in the box provided on the right of each question and those to Section B must be written in the spaces provided.
4. You will not be provided with any additional paper.
5. Unnecessary crossing of answers and illegible handwriting may lead to loss of marks.
6. Where necessary take
 - Acceleration due to gravity is 10.0 m/s^2 .
 - Velocity of light in vacuum is $3.0 \times 10^8 \text{ m/s}$.
 - Velocity of sound is 330 m/s .
 - Permittivity of free space is $9 \times 10^9 \text{ Coul}^2/\text{Newton-m}^2$.
 - S.h.C of copper 400J/kgK.
 - S.h.C of water 4200J/kgK.

SECTION A

Q1: Which of the following sets represents fundamental quantities of measurements only in physics?

- A. Mass, Density and Time.
- B. Volume, Mass and Density.
- C. Mass, Length and Time.
- D. Weight, Force and Pressure.

Q2: In machines power is defined as

- A. ability to do work.
- B. rate of doing work.
- C. product of mass and acceleration.
- D. ratio of mechanical advantage to velocity ratio.

Q3: When the hole of a pinhole camera is enlarged,

- A. several images are formed.
- B. a reduced image is formed.
- C. a blurred magnified image is formed.
- D. a clear magnified image is formed.

Q4: Which of the following statements is true about water waves?

- A. The wave length is shorter in shallow water than in deeper water.
- B. The frequency of the wave is inversely proportional to the speed.
- C. The speed of the wave is higher in shallow water than in deeper water.
- D. The wave length is the same in both shallow and deep water.

Q5: A given mass of gas occupies a volume of 3.0m^3 at a temperature of 37°C . Find its volume at 10°C if the pressure remains constant?

A. $\frac{3.0 \times 283}{310}$

B. $\frac{310 \times 3.0}{283}$

C. $\frac{3.0 \times 10}{37}$

D. $\frac{310 \times 283}{3.0}$

Q6: Figure 1 shows an experiment to demonstrate Brownian motion using a smoke cell. What is observed through the microscope when the temperature is raised?

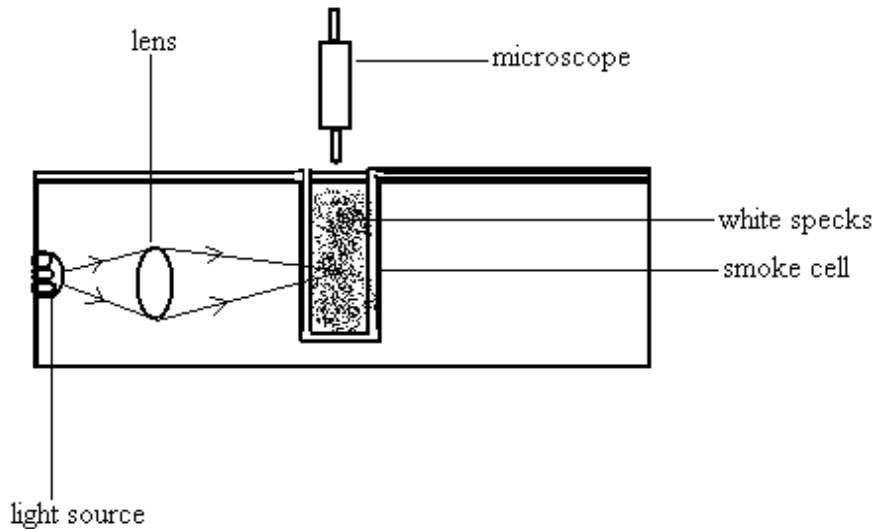

FIGURE 1

- A. The smoke particles increase in number.
- B. The speed and collision of the particles increase.
- C. No change in observation occurs.
- D. The smoke particles will appear stationary.

Q7: Total internal reflection occurs when

- A. the angle of incidence in a denser medium is greater than the critical angle.
- B. the angle of incidence in a less dense medium is 90° .
- C. the angle of incidence is 45° in a less dense medium.
- D. the angle of incidence in a dense medium equals to angle of refraction.

Q8: Which of the following statements is true?

- A. The image in a plane mirror is magnified.
- B. The image in a plane mirror is laterally inverted.
- C. The image in a convex mirror is always magnified.
- D. The image in a concave mirror is always real.

Q9: The cores of electromagnets are laminated in order to

- A. reduce the rate of formation of eddy currents.
- B. keep the core hot.
- C. form permanent magnet.
- D. increase the rate of heat generation.

Q10: One major use of x-rays in hospital is to

- A. test for HIV/AIDS virus.
- B. treat peoples suffering from river blindness.
- C. detect broken bones and fractures.
- D. detect cancer in the body.

Q11: Convex mirrors are used as driving mirrors instead of concave mirrors because

- A. they produce magnified and clear image.
- B. they form real image.
- C. they have wider fields of view.
- D. they form virtual and inverted images.

Q12: The temperature of water of mass 30g is raised from 20°C to 40°C .
Calculate the amount of heat gained by water.

- A. 25,0000J.
- B. 75,600J.
- C. 25,200J.
- D. 4560J.

Q13: The dimensions of a metal box in Figure 2 is 30cm × 20cm × 10cm. If the mass of the box is 12kg find the minimum pressure that it can exert on its support.

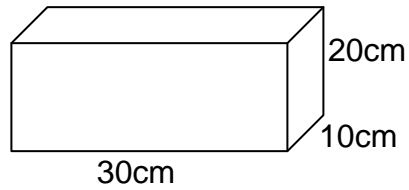

FIGURE 2

A. $\frac{12}{0.3 \times 0.2} \text{Nm}^{-2}$

B. $\frac{120}{0.2 \times 0.1} \text{Nm}^{-2}$

C. $\frac{120}{0.3 \times 0.2} \text{Nm}^{-2}$

D. $\frac{12}{0.2 \times 0.1} \text{Nm}^{-2}$

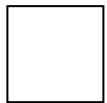

Q14: Which of the following graphs below shows distance – time graph of a body thrown vertically upwards?

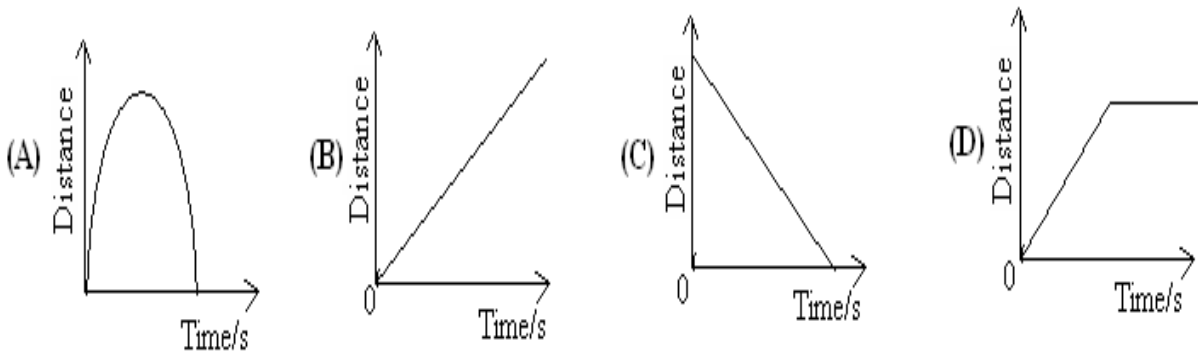

Q15: A child standing in front of a high cliff makes a loud sound; and hears an echo after 4s. Calculate how far the child is from the cliff.

A. 82.5 m.

B. 165.0 m.

C. 660.0 m.

D. 1320.0 m.



Q16: The rate of decay of a radioactive material depends on

- A. the surrounding temperature.
- B. the mass of the material.
- C. the surrounding pressure.
- D. The chemical combinations.

Q17: A battery of e.m.f 12V and negligible internal resistance is connected to 6Ω and 3Ω resistors. Find the maximum current that can be produced from the combination.

- A. 1.0A.
- B. 6.0A.
- C. 9.0A.
- D. 18.0A.

Q18: Insulators are described as

- A. materials which allow heat to pass through them.
- B. material that can be charged by induction.
- C. materials which do not have free and mobile electrons.
- D. material which have free and mobile electrons.

Q19: When an unknown particle X is used to bombard a lithium atom, two alpha particles are produced according to the following equation.

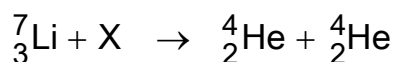

Identify particle X.

- A. A beta particle.
- B. An alpha particle.
- C. A neutron.
- D. A proton.

Q20: The magnitude of the force on a coil of a direct current motor depends on

- A. the length only.
- B. the length, the magnetic field and area only.
- C. the length, the number of turns and the magnetic field.
- D. the current, the magnetic field, the number of turns and the length.

Q21: The upthrust on a body acts

- A. horizontally.
- B. in all directions.
- C. in the opposite direction to the weight.
- D. in the same direction as the weight.

Q22: An echo is

- A. a reflected sound.
- B. a refracted sound.
- C. an absorbed sound.
- D. sound from a drum.

Q23: Linear magnification is

- A. the product of image distance and object distance.
- B. the reciprocal of the focal length.
- C. the ratio of image height to object height.
- D. image distance divided by focal length.

Q24: Infra red radiations is detected by

- A. an aerial.
- B. a thermopile.
- C. an ammeter.
- D. a voltmeter.

Q25: A stone of mass 200g falls from a height of 3.2m above the ground. Find the velocity with which it strikes the ground.

- A. 1.6 ms^{-1} .
- B. 8.0 ms^{-1} .
- C. 64.0 ms^{-1} .
- D. 128 ms^{-1} .

Q26: A gold leaf electroscope can be used to

- (i) detect the presence of charge on a body
- (ii) determine the magnitude of charge on a body
- (iii) test for the nature of charge on a body.
- (iv) test for the nature of charge on a body.

- A. (i), (ii) and (iii) only.
- B. (i) and (iv) only.
- C. (iii) and (iv) only.
- D. (ii) and (iv) only.



Q27: The order of the energy changes that take place when switch, K, is closed in Figure 3 is

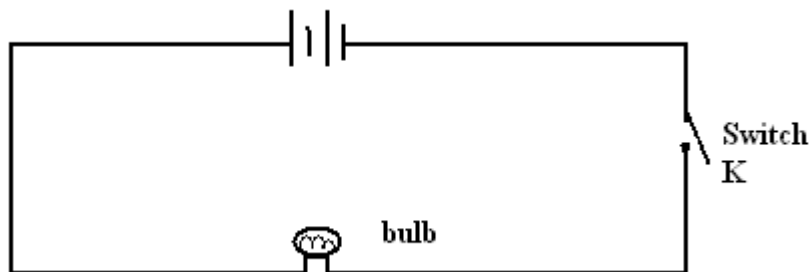
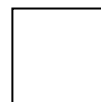

FIGURE 3

- A. Light → chemical → electrical → heat.
- B. Chemical → electrical → heat → light.
- C. Heat → light → electrical → chemical.
- D. Electrical → light → chemical → heat.



Q28: The process by which electromagnetic radiation causes electrons to be emitted from a metal surface is called

- A. thermionic emission.
- B. photoelectric effect.
- C. radioactivity.
- D. rectification.

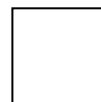

Q29: Weight is a physical quantity that

- (i) has magnitude and direction
- (ii) depends on location of an object
- (iii) increases with temperature.

- A. (i) only.
- B. (i) and (iii) only.
- C. (i) and (ii) only.
- D. (i), (ii) and (iii).

Q30: Determine the frequency of the wave shown in figure 4:

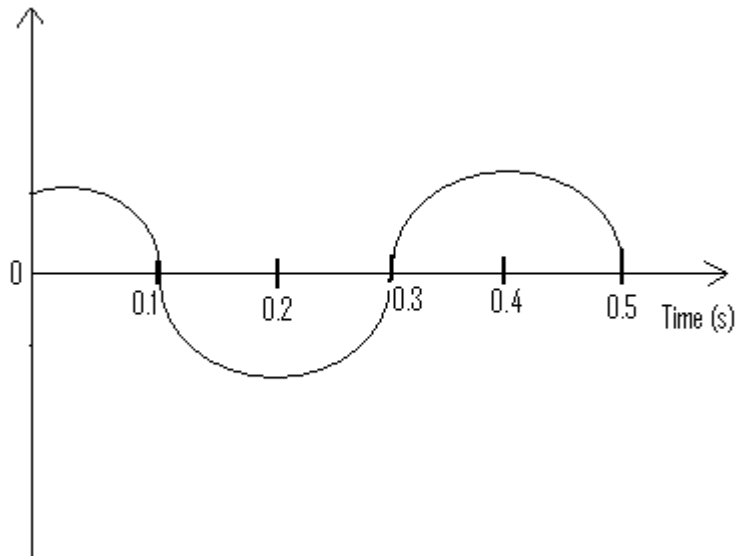

FIGURE 4

- A. 2.0 Hz.
- B. 2.5 Hz.
- C. 3.3 Hz.
- D. 5.0 Hz.

Q31: A concentrated solution of Potassium Permanganate at the bottom of a container containing water, spreads throughout the water by a process called.

- A. Osmosis.
- B. Expansion.
- C. Adhesion.
- D. Diffusion.

Q32: When two similar poles of two bar magnets are brought nearer to each other

- A. Magnetization occurs.
- B. Attraction occurs.
- C. Repulsion occurs.
- D. Demagnetization occurs.

Q33: The cathode rays are

- A. neutrons.
- B. protons.
- C. Gamma rays.
- D. electrons.

Q34: A passenger in a bus jerks forward when the driver suddenly applies the brakes because of

- A. centripetal force.
- B. centrifugal force.
- C. inertia.
- D. impulse.

Q35: Alpha particles:

- (i) travel in straight lines
- (ii) affect photographic plates
- (iii) have no charge

- A. (i) only.
- B. (i) and (ii) only.
- C. (ii) and (iii) only.
- D. (i), (ii) and (iii).

Q36: Figure 5 shows three resistors of resistances: 10Ω , 30Ω and 40Ω connected to a circuit. What is the effective resistance in the circuit?

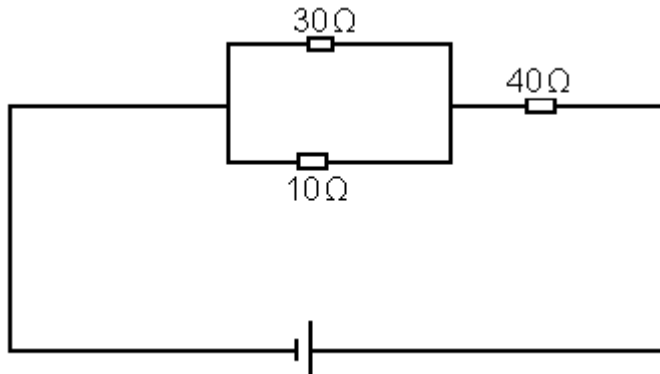
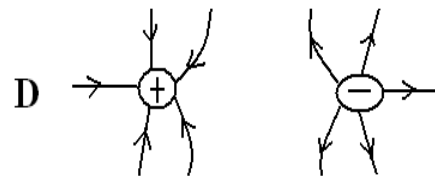
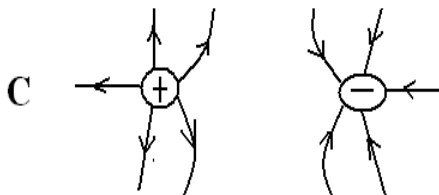
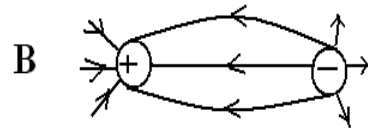
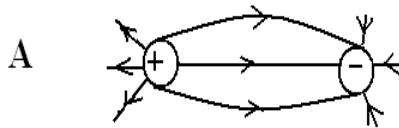

FIGURE 5

- A. 20Ω .
- B. 47.5Ω .
- C. 60Ω .
- D. 80Ω .

Q37: Which one of the following represents the correct electric field pattern for two opposite charge points placed near one another?



Q38: Cathode ray oscilloscope (CRO) measures

- A. the quantity of charge.
- B. the electrical energy.
- C. only the amplitude of dc voltage.
- D. both amplitudes of dc and ac voltages.

Q39: Figure 6 shows a fluid flowing from one end to another.

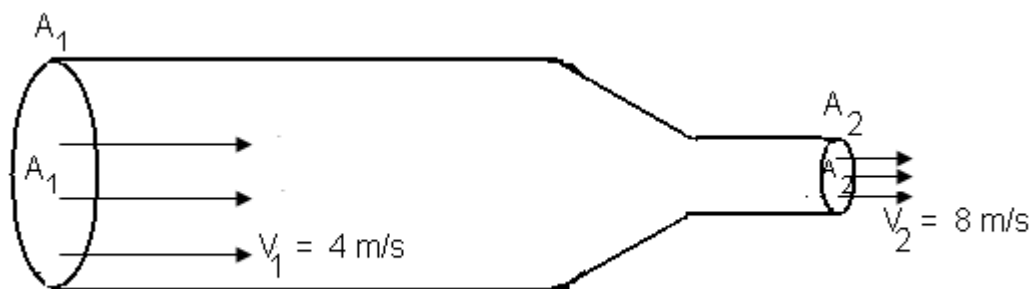

FIGURE 6

If the cross-sectional area $A_1=30\text{cm}^2$, determine the cross-sectional area A_2 .

A. $\frac{0.3 \times 4}{8} \text{cm}^2$

B. $\frac{30 \times 4}{8} \text{cm}^2$

C. $\frac{30 \times 4}{80,000} \text{cm}^2$

D. $\frac{30 \times 4}{800} \text{cm}^2$



Q40: The fourth energy level of an atom is -0.85 eV . Calculate the first energy level of this atom.

A. -13.6 eV .

B. -1.5 eV .

C. -3.4 eV .

D. -0.66 eV .

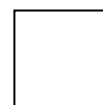

SECTION B

Q41: (a) (i) Define capacitance of a capacitor. (1 mark)

(ii) State the unit of capacitance. (1 mark)

(b) State any two factors that affect capacitance of a capacitor.

(c) Sketch the distribution of charge on the conductor in Figure 7.

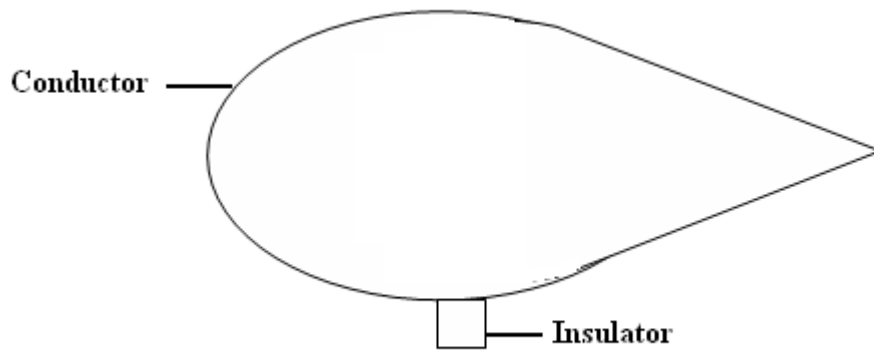

FIGURE 7

Q42: (a) State any two properties of electromagnetic radiation.

(i) _____

(ii) _____

(2 marks)

(b) (i) List any two uses of gamma ray.

(2 marks)

(ii) A South Sudan broadcasting station sends out radio waves of wave length 1600m. Calculate the frequency of the waves. **(2 marks)**

Q43. (a) (i) Define the term refraction of light. **(1 mark)**

(ii) Illustrate your response to (i) by means of a sketch diagram. **(1 mark)**

(b) (i) The critical angle at the glass-air interface is 42° . Find the refractive index of the glass. **(4 marks)**

(ii) State any two reasons why a prism is preferred to a plane mirror in a periscope.

44. (a) State Charle's law. (1 mark)

(b) Convert 300K to Celsius scale. (1 mark)

(c) A given mass of gas exerts a pressure of $2.0 \times 10^1 \text{Pa}$ at a temperature of 27°C . If the volume is fixed, calculate the pressure exerted by the gas at 280°C . (4 marks)

Q45: (a) State the principle of transmission of pressure in liquids? (1 mark)

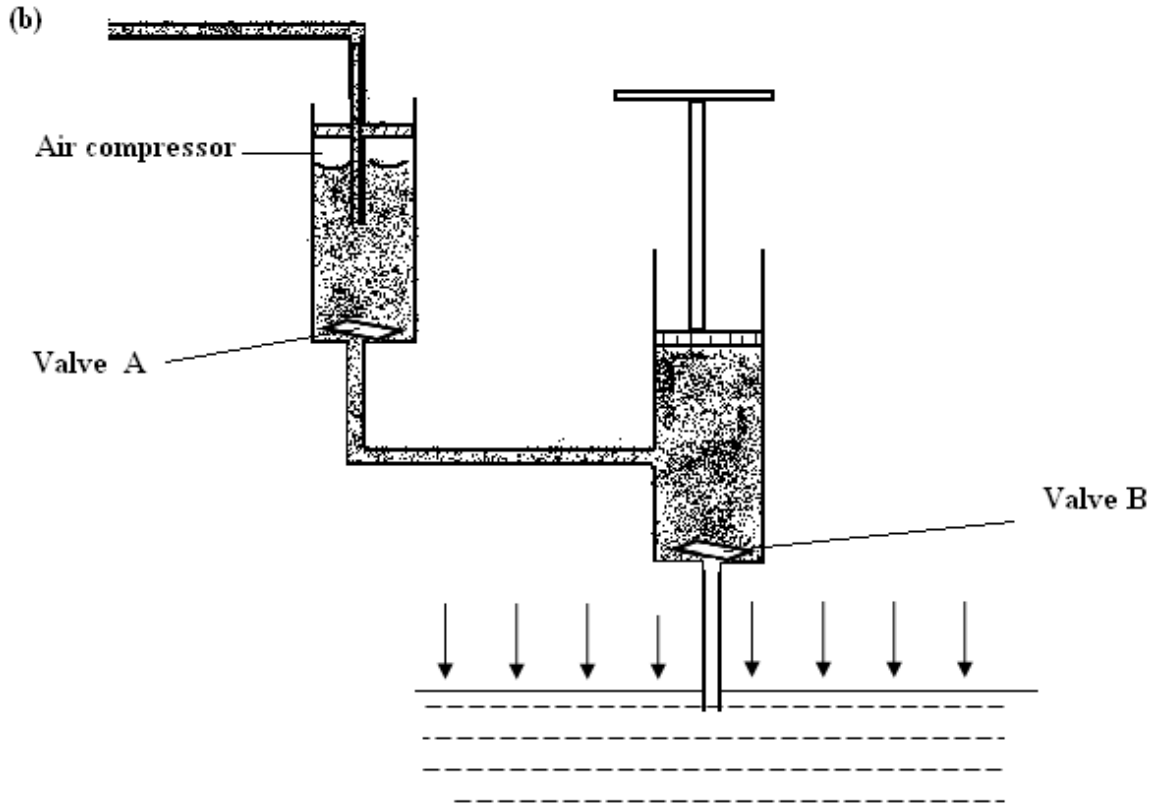

FIGURE 8

The diagram in Figure 8 shows a force pump. Briefly explain what happens to valves A and B during

(i) Upstroke
 Valve A: _____

Valve B: _____

(2 marks)

(c) What is the function of the air space inside the cylinder? **(1 mark)**

Q46: (a) (i) Distinguish between ferromagnetic and non-magnetic substance.

(1 mark)

(ii) Give an example of a non magnetic materials.

(1 mark)

(b) What is meant by mutual induction?

(1 mark)

(c)

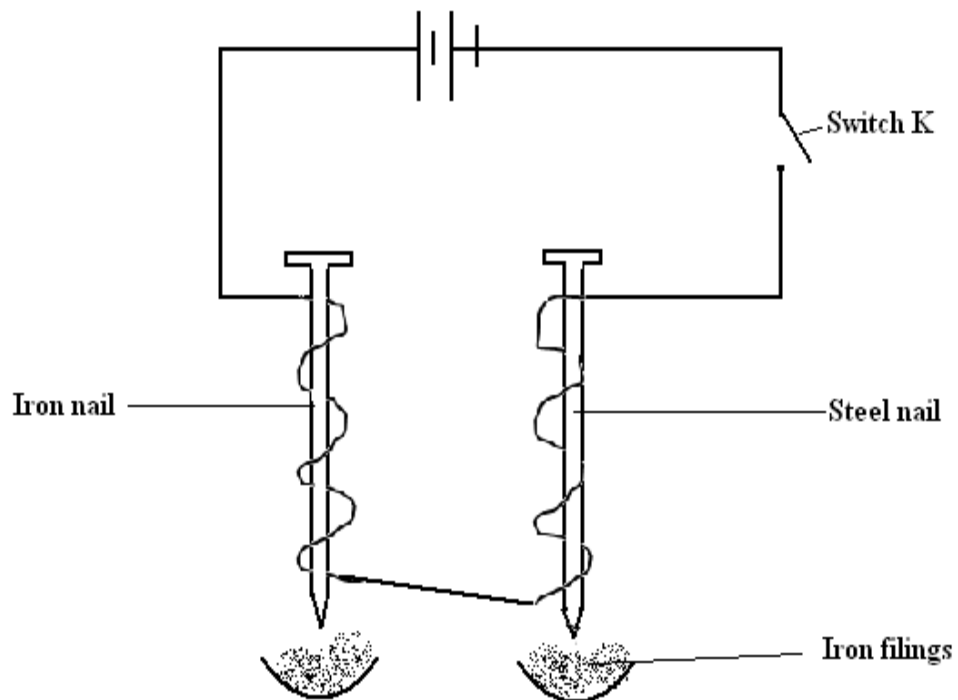

FIGURE 9

(i) Describe what is observed when switch, K, is closed in Figure 9.

(1 mark)

(ii) Describe what is observed when switch K is opened again.

(1 mark)

(iii) Explain the reasons for what you observe in c(i).

(1 mark)

Q47: (a) State two reasons, why the efficiency of a pulley system is less than 100%. **(2 marks)**

(i) _____

(ii) _____

(b) (i) How can efficiency of a machine be improved? **(1 mark)**

- (ii) A force of 400 N is used to raise a load of 600 N using a pulley system as shown above. Calculate the efficiency of the pulley system. **(3 marks)**

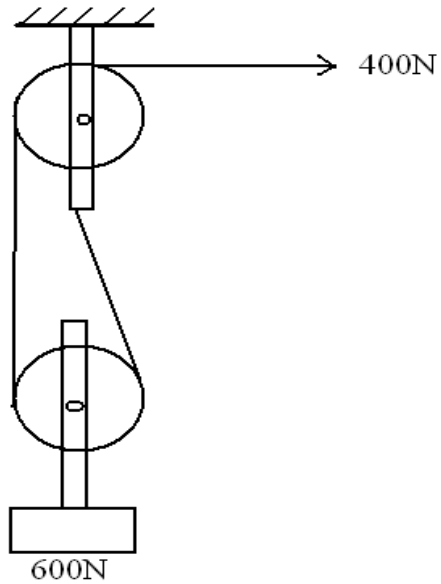

FIGURE 10

- Q48: (a) State Ohm's law. **(1 mark)**

- (b) State two factors that affect resistance of a conductor. **(2 marks)**

(3 marks)

A battery of e.m.f 3V is connected across 2Ω and 4Ω resistors as shown in figure 11. Calculate the total current in the circuit.

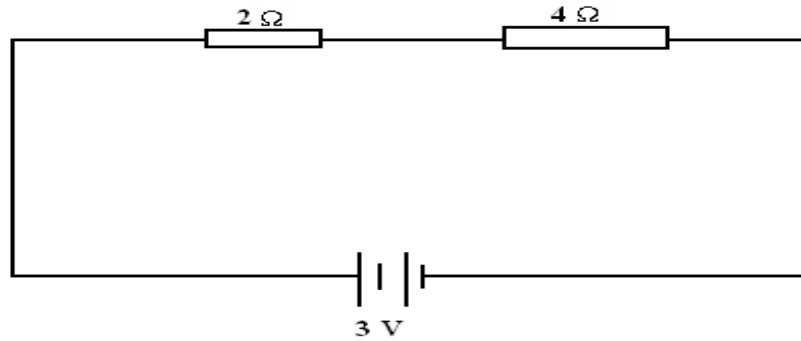

FIGURE 11

Q49: (a) Define the term principle focus of a concave mirror. (1 mark)

(b) (i) An object O, is placed in front of a convex mirror as shown in Figure 12. Use rays construction to locate the image and its position (3 marks)

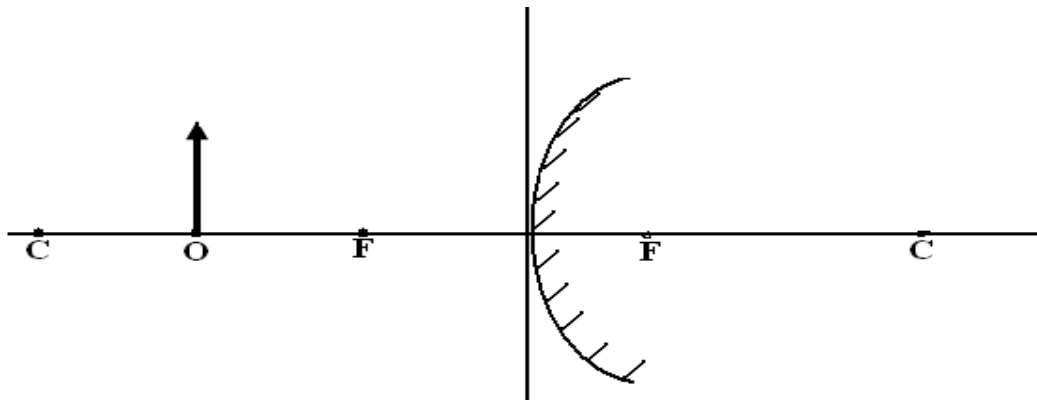

FIGURE 12

(ii) State four characteristics of the image formed. **(2 marks)**

Q50: (a) (i) State the principle of moments. **(2 marks)**

(ii) State its unit

(b) List two conditions necessary for a uniform beam to be in equilibrium. **(2 marks)**

(i) _____

(ii) _____

(c) What is meant by

(i) the centre of gravity

(ii) stable equilibrium? **(2 marks)**

END



**GOVERNMENT OF SOUTHERN SUDAN
MINISTRY OF EDUCATION
EXAMINATIONS SECRETARIAT**



**SOUTHERN SUDAN CERTIFICATE OF SECONDARY EDUCATION (S.S.C.S.E)
EXAMINATIONS**

Nov./Dec. 2010

**041/2 PHYSICS
PAPER TWO
3 HOURS**

NB: NAME (CAPITAL LETTERS):

INDEX NUMBER SIGNATURE.....

Must be written on all answer booklets used.

INSTRUCTIONS

Read the instructions carefully before answering any question.

1. Attempt any **five** questions in the answer booklet provided.
2. You may use the following constants:
 - (a) Acceleration due to gravity, $g=10 \text{ m/s}^2$.
 - (b) Velocity of light = $3 \times 10 \text{ m/s}^2$.
 - (c) Specific heat capacity of water = 4200 J/gK .
 - (d) Specific latent heat of fusion of copper = 400 J/kgK
 - (e) Specific latent heat of fusion of water = 3400 J/kg .

- Q1: (a) (i) Define energy and state its unit. **(2 marks)**
- (ii) List five (5) sources of energy. **(5 marks)**
- (b) (i) What is a machine? **(1 mark)**
- (ii) Mention two ways by which the efficiency of a machine can be lowered. **(2 marks)**
- (iii) A force applied parallel to an inclined plane is used to raise a load of 500 N through a height of 3.0 m. The load moves through a distance of 30 m along the plane.
- (a) How much work is done on the load? **(2 marks)**
- (b) If the efficiency of the system is 80%, determine the effort applied when velocity ratio is 10. **(3 marks)**
- (c) How much work is done by the effort? **(3 marks)**
- (d) What is meant by the following terms?
- (i) Mechanical advantage, (MA). **(1 mark)**
- (ii) Velocity Ratio, (VR)? **(1 mark)**
- Q2: (a) State Newton's laws of motion. **(3 marks)**
- (b) Use Newton's second law of motion to show that $F=ma$. Where F is the resultant force, m , and, a , are the mass and acceleration of the body respectively. **(4 marks)**
- (c) A car of mass 1000 kg traveling at 36 km/h is brought to rest over a distance of 20 m. Find
- (i) the average retardation. **(4 marks)**
- (ii) the average braking force. **(3 marks)**
- (d) (i) Define the centre of gravity of a body. **(1 mark)**
- (ii) State the conditions of equilibrium when a body is acted upon by a number of parallel forces. **(2 marks)**
- (iii) A uniform metre rule balances horizontally when a mass of 40 g is hung at 0 cm mark as shown in Figure 1. Find the mass of the metre rule. **(3 marks)**

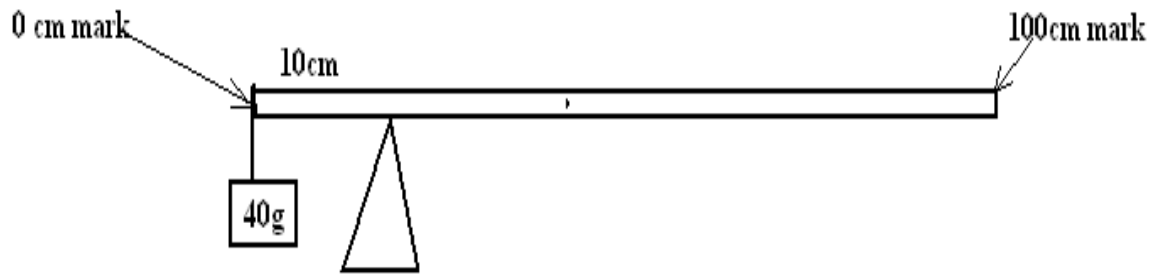

FIGURE I

- Q3: (a) Distinguish between longitudinal and transverse waves. Give one example each. **(4 marks)**
- (b) Describe an experiment using a ripple tank to show interference of water waves. **(4 marks)**
- (c) (i) What are the conditions for standing wave? **(2 marks)**
(ii) Name two instruments where standing waves are applied. **(2 marks)**
- (d) (i) Draw a labeled diagram of the electromagnetic spectrum. **(3 marks)**
(ii) Indicate the direction in which frequency and wavelength increase. **(1 mark)**
- (e) A child stands between two cliffs and makes a loud sound. If the child hears the first echo after 1.5 s and the second echo after 2.0 s, find the distance between the two cliffs. **(4 marks)**

Q4: (a) State the three modes of heat transfer.

(3 marks)

(b)

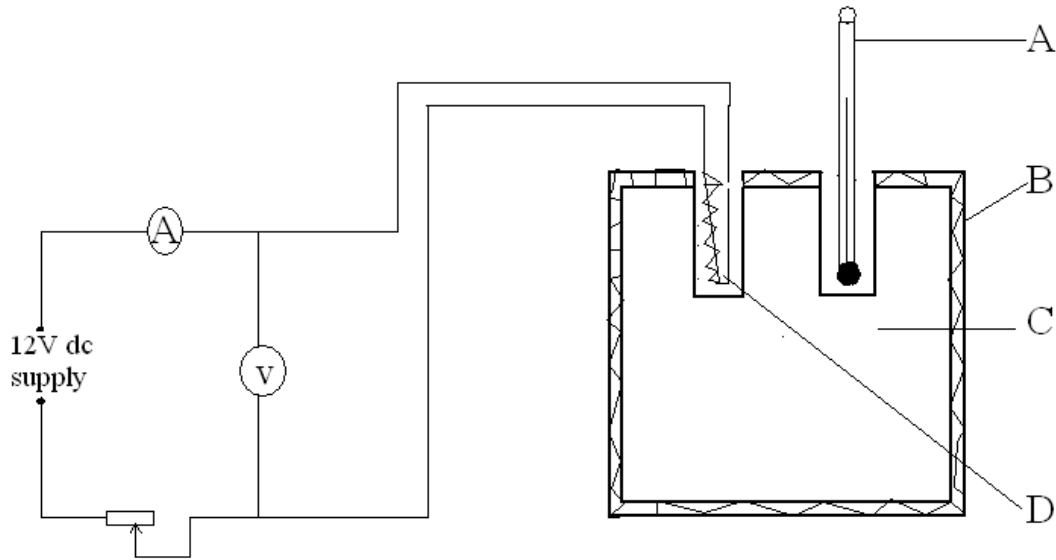

FIGURE 2

The diagram in figure 2 shows an electrical method for measuring the specific heat capacity of metal.

Name the parts labeled A, B, C, and D.

(4 marks)

(ii) Briefly list the measurements that are recorded.

(5 marks)

(iii) Write an expression for the specific heat capacity of a metal. (1 mark)

(c) (i) Explain why in cold weather water pipes tend to burst.

(2 marks)

(ii) State any two reasons why water is not a suitable thermometric substance.

(2 marks)

(d) Explain the difference between music and noise

(3 marks)

- Q5: (a) Define the following terms:
- (i) Reflection. (1 mark)
 - (ii) Magnification. (1 mark)
- (b) Briefly explain how the image is formed in a pinhole camera. (8 marks)
- (c) By means of diagrams, distinguish between regular and diffuse reflection. (4 marks)
- (d) (i) State the two laws of refraction. (2 marks)
- (ii) A burning candle of height 5 cm is placed 10 cm in front of a concave lens of focal length 15 cm. Find the position and height of the image. (4 marks)
- Q6: (a) Differentiate between primary and secondary cells; giving two examples of each. (4 marks)
- (b) Explain the defects of a simple cell and describe how they are overcome. (6 marks)
- (c) (i) State two advantages of alkaline accumulator over lead acid accumulator. (2 marks)
- (ii) How can an accumulator be maintained so that it lasts for a long time? (3 marks)
- (d) An accumulator is rated 24V, 2.5A. Calculate:
- (i) the power input when the accumulator is in use. (3 marks)
 - (ii) the energy dissipated by the accumulator when in use for 10 s. (2 marks)
- Q7: (a) Define the term mutual induction. (1 mark)
- (b) (i) What is a transformer? (1 mark)
- (ii) Distinguish between step-up and step-down transformers. Illustrate your answer with the help of diagrams. (4 marks)
- (c) A transformer has 400 turns in the primary winding and 10 turns in the secondary winding. If the voltage and current in the primary are 250 V, and 2.0 A respectively,

Calculate:

- (i) the secondary voltage. (3 marks)
 - (ii) the secondary current, assuming 100% efficiency . (3 marks)
 - (d) (i) Define sensitivity of a galvanometer. (1 mark)
 - (ii) What are the factors which determine high sensitivity of a galvanometer? (4 marks)
 - (e) A moving-coil galvanometer has a resistance of 40Ω and gives a full-scale deflection of 2mA. Calculate the maximum voltage that it can measure. (3 marks)
- Q8:
- (a) (i) Define photoelectric effect. (1 mark)
 - (ii) State the factors that affect photoelectric emission. (3 marks)
 - (iii) What are the uses of photoelectric effect? (3 marks)
 - (b) (i) Draw a well labeled diagram of an x-ray tube. (3 marks)
 - (ii) Explain how x-rays are produced in an x-ray tube. (3 marks)
 - (iii) Explain how x-rays are used to detect bone fracture. (3 marks)
 - (iv) State any **two** health hazards of x-rays. (2 marks)
 - (d) State any two differences between x-rays and Beta-particles. (2 marks)

END



Republic of South Sudan
Ministry of General Education & Instruction
Secretariat of Examinations

041/1
PHYSICS
Paper 1
3 hours

SOUTH SUDAN CERTIFICATE OF SECONDARY EDUCATION (S.S.C.S.E)

EXAMINATIONS

PHYSICS
PAPER 1

TIME: 3 HOURS

INSTRUCTIONS

Read the instructions carefully before answering any question.

1. The paper consists of two Sections, A & B.
Section A contains 40 Multiple Choice questions which carry 40 marks
Section B contains 10 Structured questions which carry 60 marks.
2. Candidates are required to answer all questions on the question paper.
3. Answer to Section A are to written in the box provided on the right of each question and those of Section B in the spaces provided on the question paper.
4. You will not be provided with additional paper besides this.
5. Unnecessary crossing of answers and illegible handwriting may lead to loss of marks.
6. Where necessary use the following constants:
 - Acceleration due to gravity $g = 10\text{ms}^{-2}$
 - Density of water $= 1000 \text{kgm}^{-3}$
 - Density of paraffin 800kgm^{-3}
 - s.h.c of copper $400\text{Jkg}^{-1}\text{k}^{-1}$
 - s.h.c of paraffin $2000\text{Jkg}^{-1}\text{k}^{-1}$
 - Speed of light $30 \times 10\text{ms}^{-1}$
 - Charge on an electron $1.6 \times 10^{-19}\text{C}$
 - Mass of an electron $9.1 \times 10^{-31}\text{kg}$

SECTION A (40 MARKS)

Q.1 The length of a pendulum is proportional to:

- A. mass of the bob.
- B. periodic time.
- C. square of the periodic time.
- D. acceleration due to gravity.

Q.2 What is the velocity ratio of the machine shown in Fig. 1?

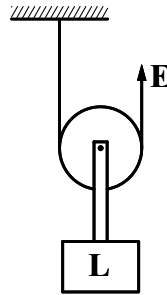

- A. 1.
- B. 2.
- C. 3
- D. 5

Q.3 A blurred image in a pin-hole camera is due to

- A. overlapping of images
- B. diffraction of light
- C. reflection of light
- D. refraction of light

Q.4 Vertical polarization of transmitting aerial is produced when,

- A. an aerial received a vertical wave
- B. an aerial received a horizontal wave
- C. a vertical aerial received a vertical wave
- D. a vertical aerial received horizontal wave.

Q.5 The pressure in a cylinder when the volume of air is 50 cm^3 at 17°C is 1.0 atmosphere. The pressure in atmospheres when the air is compressed to 10 cm^3 and its temperature rises to 27°C is,

- A. 5.2
- B. 52.0
- C. 7.9
- D. 80.0

Q.6 Which of the following is not true about force?

- A. A force causes bodies to move.
- B. A force causes a body to change shape.
- C. A force causes a body to accelerate.
- D. A force causes the mass of a body to increase.

Q.7 Two forces of magnitudes 6 N and 8 N act at point P as shown in figure 2. What is the magnitude of the resultant force?

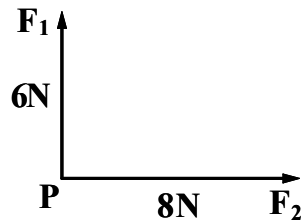

- A. 10 N
- B. 14 N
- C. 20 N
- D. 100 N

Q.8 A mercury drop on a glass rod forms a spherical drop while a water drop spreads on a glass rod. This is because

- A. adhesive drop in mercury is greater than its cohesive force.
- B. mercury force has greater cohesive force than water.
- C. mercury drop has greater adhesive force than water.
- D. Mercury has higher density than water.

Q.9 Which one of the following explains why an object is not recognised when a parallel beam from the object is reflected from a rough surface?

- A. The Laws of reflection are not obeyed in scattered reflection.
- B. The angles of incidence and reflection varies.
- C. Some rays are absorbed.
- D. Incidence rays are scattered.

- Q.10 A ray of light travelling from glass to air is refracted as shown in figure 3. If the refractive Index of glass is 1.5. What is the value of angle (i)?

Fig.3

- A. 41.8°
- B. 52°
- C. 60°
- D. 30°

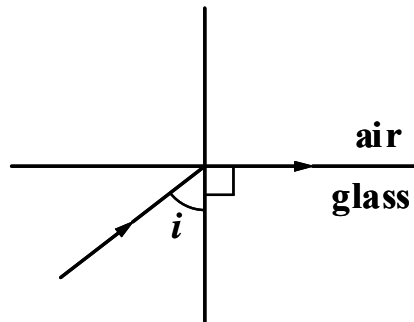

- Q.11 Calculate the number of turns on the secondary of the step-down transformer, which would enable a 12 V bulb to be used with a 240V A.C main supply power, if there are 480 turns on the primary.

- A. 48.
- B. 240.
- C. 24.
- D. 254.



- Q.12 An x-ray tube operates with a potential difference of the 100 KV between the anode and cathode. If the tube current is 10 mA, what is the rate at which energy is transformed to the target of the x-ray tube?

- A. 10 KW
- B. 1.0 KW
- C. 4 KW
- D. 2 KW.

- Q.13 A density bottle has a mass of 70 g when empty, 90 g when full of water and 94 g when full of a liquid. What is the relative density of the liquid?

- A. 2.4.
- B. 1.2.
- C. 2.0
- D. 24.0

Q.14 Which one of the following contains a list of primary colours?

- A. Blue, Red and Yellow.
- B. Blue, Red and Green.
- C. Red, Yellow and Green.
- D. Red, Green and Magenta.

Q.15 A current of 2.5 A passing through a heating coil immersed in 180 g of paraffin contained in a 100 g copper calorimeter, raises the temperature from below 5°C above room temperature in 100 s. What is the reading of the voltmeter connected across the coil?

- A. 16.0 V
- B. 20.0 V
- C. 12.0 V
- D. 24.0 V

Q.16 The diagram in figure 4 shows variation in current with p.d in a vacuum diode. In which region is the rate of arrival of electrons at the anode constant?

Fig. 4

- A. OB
- B. AB
- C. OA
- D. BD

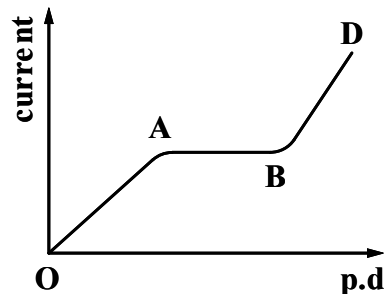

Q.17 Figure 5 shows a mercury barometer. What is the value of the atmospheric pressure?

Fig. 5

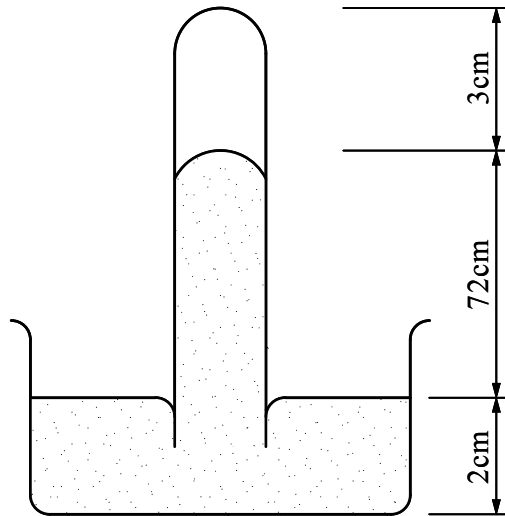

- A. 72 cm
- B. 74 cm
- C. 75 cm
- D. 77 cm

Q.18 what is the angular velocity of a turntable which makes 33 revolutions per minute?

- A. $2.1\pi \text{ rads}^{-1}$
- B. $2.2\pi \text{ rads}^{-1}$
- C. $1.2\pi \text{ rads}^{-1}$
- D. $1.1\pi \text{ rads}^{-1}$

Q.19 The speed of an electromagnetic wave is $3.0 \times 10^8 \text{ ms}^{-1}$ and its wave length is $2.0 \times 10^{-6} \text{ m}$. find the frequency of the wave?

- A. 6.0×10^{14}
- B. 6.0×10^{15}
- C. 1.5×10^{14}
- D. 1.5×10^{15}

Q.20 In long-sightedness, the image of the object at normal near point is formed

- A. On the retina.
- B. Beyond the retina.
- C. In front of the retina.
- D. Between the lens and the retina.

Q.21 The diagram in figure 6 shows the path of the radiations emitted by the radioactive source. Which radiation is most likely to be detected?

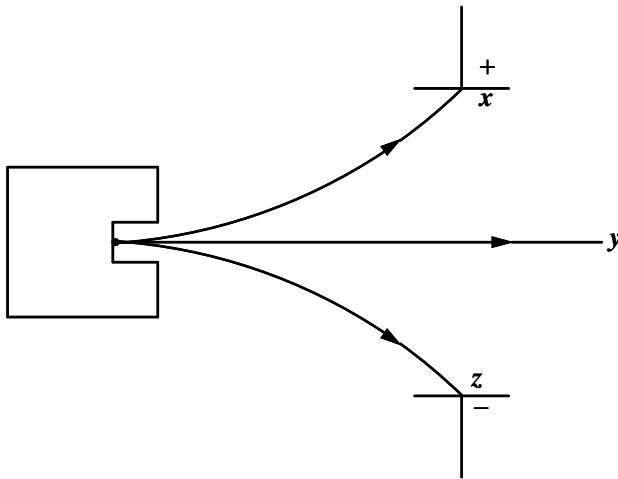

- A. Neutron.
- B. Beta particle.
- C. Alpha particles.
- D. Gamma particles.

Q.22 A 12V accumulator is connected across resistors of 5.8Ω , 2Ω and 3Ω as shown in Figure 7.

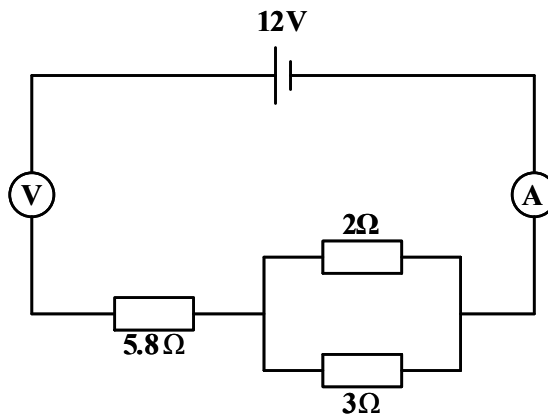

What is the reading of the ammeter (A)?

- A. 2.0 A
- B. 6.0 A
- C. 1.2 A
- D. 5.0 A

Q.23 Which of the following explains why lightning conductor rods are sharp pointed?

- A. For discharge of cloud charges.
- B. For corona discharge.
- C. For induction.
- D. For ionisation.

Q.24 In an experiment to examine the relationship between current and voltage a cross p-n junction diode, the small current in reverse bias is due to

- A. Intrinsic conduction in p-n junction diode.
- B. Extrinsic conduction in p-n junction diode.
- C. Intrinsic conduction in n-p junction diode.
- D. Intrinsic conduction in p junction diode.

Q.25 The principle of operation of a telephone receiver differs from that of an electric bell in that

- A. Telephone receiver has soft iron pole pieces.
- B. Telephone receiver has a soft iron bar.
- C. Telephone receiver has a permanent magnet.
- D. Telephone receiver has a gong.

Q.26 Which one of the following is **not** effect of prolonged exposure of minerals to radioactive emissions?

- a. Destruction of the cell
- b. Alteration of genetic makeup of a human being
- c. Rise in blood pressure
- d. Skin burns, cancer and leukaemia

Q.27 The relative density of liquids can be measured by hydrometer because;

- A. The mass of a floating object varies with density.
- B. Volume of a floating object varies with density.
- C. Mass of a floating object is constant.
- D. Relative density of the liquid varies with density.

Q.28 The graph in Figure 8 shows a volume- temperature relationship?

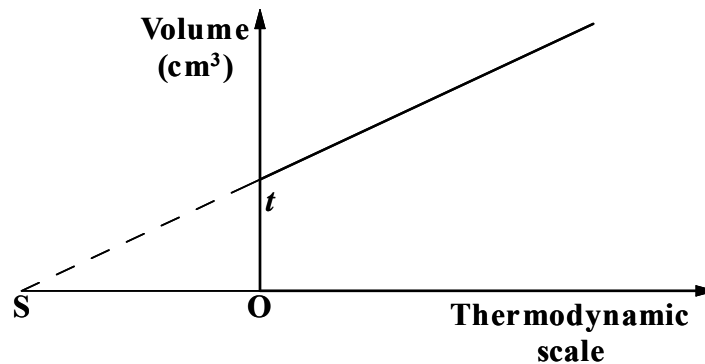

The intercept S on the temperature axis is an assumption because

- A. S is absolute temperature.
- B. T is absolute temperature.
- C. Gases liquefy after S.
- D. Gases liquefy before S.

Q.29 What causes self- demagnetisation in a bar magnet?

- A. Alignment of atomic dipoles.
- B. Disorder of atomic dipoles.
- C. Attraction of polarities.
- D. Repulsion of polarities.

Q.30 Which one of the following is **NOT** an application of echo?

- A. Measurement of velocity of sound.
- B. Echo sounding.
- C. Detection of fracture.
- D. Anechoic and soundproof room.

Q.31 A convex lens has a focal length of 20 cm. what is its power?

- A. 0.2 D
- B. 0.1 D
- C. 5.0 D
- D. 0.5 D

Q.32 Which one of the following property does not change when light travel from one medium to another?

- A. Wave length.
- B. Frequency.
- C. Speed.
- D. Direction.

Q.33 Figure 9 shows a U-tube containing two liquids L1 and L2 of densities 0.8 gcm^{-3} and 1.8 gcm^{-3} respectively in equilibrium. Given that $h_2 = 8 \text{ cm}$, determine the value of h_1

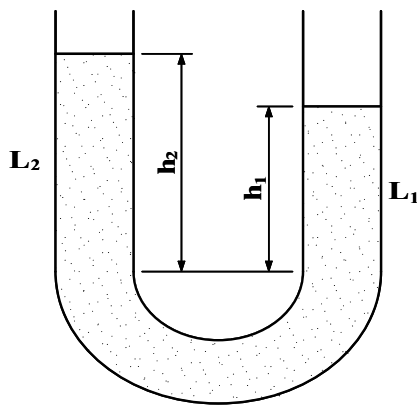

- A. 18 cm.
- B. 10 cm.
- C. 5 cm.
- D. 20 cm.

Q.34 A unit volume of a liquid falls from a surface to a depth of 0.1 m. Calculate its velocity just as it reaches the final depth.

- A. 5.0 ms^{-1}
- B. 10.0 ms^{-1}
- C. 14.0 ms^{-1}
- D. 1.4 ms^{-1}

Q.35 Both electromotive force and potential difference are measured in

- A. Volt.
- B. Voltmeter.
- C. Ampere.
- D. Ohm.

Q.36 160 g of molten silver at its melting point 960°C is allowed to solidify at the same temperature and gives out 16,800 J of the heat. What is the specific latent heat of silver?

- A. $100,000 \text{ Jkg}^{-1}$
- B. $200,000 \text{ Jkg}^{-1}$
- C. $142,000 \text{ Jkg}^{-1}$
- D. $105,000 \text{ Jkg}^{-1}$

Q.37 The velocities of a wave in deep and shallow water are $8\text{m}^{\text{s}^{-1}}$ and $6\text{m}^{\text{s}^{-1}}$ respectively. Calculate the refractive index of water.

- A. 1.63
- B. 1.53
- C. 1.33
- D. 1.50

Q.38 Figure 10 shows a simple machine used to draw water from a deep well. Find the velocity ratio of the machine.

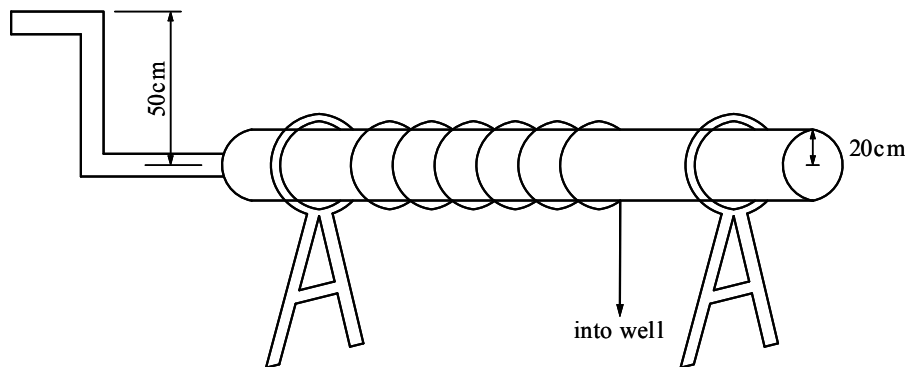

- A. 25
- B. 2.5
- C. 0.4
- D. 100

Q.39 A radio station operates on the radio wave of frequency $1 \times 10^8 \text{ Hz}$. Calculate the wave length of the radio wave.

- A. 30 m
- B. 3.0 m
- C. 1.5 m
- D. 300 m

Q.40 A radioactive source is set up in front of a Geiger-miller tube. The reading on the scale is 330 counts per minute, if the average background radiation is 30 counts per minute, calculate the correct value of the count rate.

- A. 360 count/minute.
- B. 330 count/minute.
- C. 300 count/minute.
- D. 333 count/minute.



SECTION B (60 MARKS)

1. (a) Define:

(i) Electric current [1 mark]

.....
.....
.....
.....

(ii) Internal resistance [1 mark]

.....
.....
.....

(b) State ohms law. (1 mark).

.....
.....
.....

(c) A cell having an e.m.f of 1.5 V and an internal resistance of 2.0Ω is connected in series with an ammeter of resistance 0.5Ω and a 5.0Ω resistance.

What will be?

(i) The ammeter reading (1 1/2 marks)

.....
.....
.....

(ii) The p.d across the terminal of the cell? (1 1/2 marks).

.....
.....
.....

Q.2 (a) Distinguish between nuclear fission and nuclear fusions? [2 marks]

.....
.....
.....

(b) Complete the nuclear equation below and name radiation x. [1 mark]

(i) a =

(ii) b..... [1 mark]

(iii) x=

(c) (i) What is meant by the half life of a radioactive substance? [1 mark]

.....
.....
.....
.....

(ii) The half life of a radioactive sample is 24 hours. Determine the time it will take for it's mass to fall 1/8th of the present value. [2 marks]

.....
.....
.....
.....

Q.3 (a) Differentiate between the focal point of a concave mirror and the focal point of a converging mirror? (2marks)

.....
.....
.....
.....
.....

(b) Mention any two factors which determine the magnitude of pressure at a point in a liquid. [3 marks]

.....
.....
.....
.....

(c) Calculate the pressure at point P in figure 11. [1 mark]

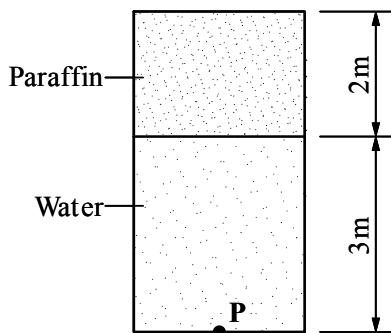

Q.6 (a) State Lenz's law of electromagnetic induction. [1 mark]

.....
.....
.....

(b) State any two factors which determine the magnitude of induced current.[2 marks]

.....
.....
.....
.....

(c) Draw a well labelled diagram of a simple alternating current (a.c) generator. [3 marks]

Q.7 (a) State the principle of conservation of energy. [1 mark]

.....
.....
.....

(b) A bullet of mass 0.01 kg and a velocity of $600\text{m}^{\text{s}^{-1}}$ is brought to rest by protective sand.

(i) Find the kinetic energy lost. [3marks]

.....
.....
.....
.....

(ii) If the bullet enters 2.4 m into the sand, what is the average force resisting the motion. [1 mark]

.....
.....
.....
.....

Q.8 (a) What is the green house effect? [2 marks].

.....
.....
.....
.....

(b) Explain how microwaves are used in satellite communication. [2 marks]

.....
.....
.....
.....

(c) Mention any two properties of a microwave which enable it to be used in satellite communication. [2 marks]

.....
.....
.....
.....

Q.9 (a) Distinguish between simple and compound microscope. (1mark)

.....
.....
.....
.....

(b) In a compound microscope, the focal length of the objective lens is 2.0 cm and that of the eye piece is 2.2 cm and they are placed 8.0 cm. A real object of size 1.0 cm is placed 3.0 cm from objective lens.

Find the distance of the

(i) Image 1, from the objective lens. [3 marks]

.....
.....
.....
.....

(ii) the final image 2 [2 marks]

.....
.....
.....
.....

Q.10 (a) Define

(i) Viscosity [1 mark]

.....
.....
.....

(ii) Terminal velocity [1 mark]

.....
.....
.....
.....

- (b) The graph in figure 12 shows a velocity-time graph for a body falling freely in a liquid.

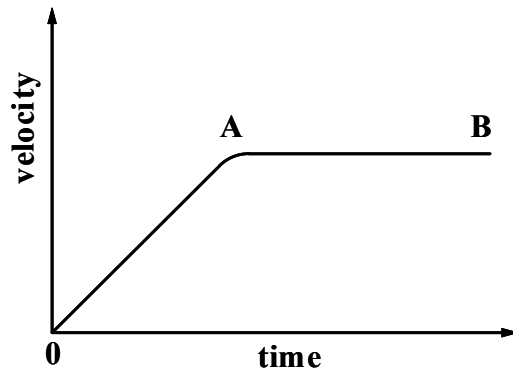

Explain what is happening in regions

- (i) OA

.....
.....
.....

- (ii) AB.

.....
.....
.....
.....(I mark)

- (c) A block of mass 272 kg is pulled along a level ground. The force of sliding friction between the block and the ground is 1000 N. If the block has an acceleration of 0.4 ms^{-2} , what is the force pulling it? [4 marks]

.....
.....
.....
.....

END



Republic of South Sudan
Ministry of General Education & Instruction
Secretariat of Examinations

041/2
PHYSICS
Paper 2
Time: 3 hours

SOUTH SUDAN CERTIFICATE OF SECONDARY EDUCATION (S.S.C.S.E)

EXAMINATIONS

PHYSICS
PAPER 2

TIME: 3 HOURS

INSTRUCTIONS

Read the instructions carefully before answering any question

- 1. Attempt any **FIVE** questions in this paper.*
- 2. You may use the following*
 - (a) Acceleration due to gravity $g = 10 \text{ m s}^{-2}$*
 - (b) Specific Heat Capacity of Water = $4200 \text{ J Kg}^{-1} \text{ K}^{-1}$*
 - (c) Specific Heat Capacity of Water = $4200 \text{ J Kg}^{-1} \text{ K}^{-1}$*
 - (d) Specific Latent Heat of fusion of Water $34000 \text{ J Kg}^{-1} \text{ K}^{-1}$*
 - (e) Velocity of Light = $3 \times 10^8 \text{ m s}^{-1}$*
 - (f) Specific Latent Heat of Steam = $2.26 \times 10^6 \text{ J/Kg}$*

- Q.1 (a) Define the following terms as applied to machines,
- (i) Velocity ratio [2 marks]
 - (ii) Mechanical advantage [2 marks]
 - (iii) Power [2 marks]
- (b) A pulley system consists of three wheels on the upper block and two wheels on the lower block with a load attached to it.
- (i) Draw a well labelled diagram of the system. [4 marks]
 - (ii) State the velocity ratio of the system. [2 marks]
 - (iii) Calculate the effort required to raise a load of 1000 N if mechanical advantage of the system is 4. [3 marks]
- (c) Draw a sketch system graph of mechanical advantage of the system in (b). [1marks]
- (d) Give three practical applications of pulleys. [3 marks]
- Q.2 (a) Explain the following terms:
- (i) Regular reflection [3 marks]
 - (ii) Irregular reflection [3 marks]
 - (iii) Total internal reflection [3 marks]
- (b) Describe an experiment to determine refractive index of a glass block [6 marks]
- (c) A ray of light is incident at 45° on face of a 60° prism of refractive index 1.5. Calculate the total deviation of the ray. [5 marks]
- Q.3 (a) Distinguish between the lower and upper fixed points of a thermometer. [2 marks]
- (b) State four basic assumptions of kinetic theory of gases. [4 marks]
- (c) Describe an experiment to determine specific heat capacity of a liquid using electrical method. [6 marks]
- (e) (i) Define the term, Specific Latent Heat of Vaporisation. [2 marks]
- (ii) Calculate the quantity of heat required to change 2.0 Kg of ice at -10.0° C to steam. [6 marks]
- Q.4 (a) Define the following terms:
- (i) Period [1 mark]
 - (ii) Frequency [1 mark]
- (b) State the factors which affect the frequency of a vibrating string. [3 marks]
- (c) Describe an experiment to show that sound requires material medium for its transmission. [5 marks]

- (d) Explain why sound is clearer at night than during day time. [3 marks]
- (e) Distinguish between progressive wave and stationary wave. [2 marks]
- (f) The equation of a progressive wave is: $Y=4 \sin \pi/25 (x-100t)$.
Find,
(i) Amplitude
(ii) Velocity
(iii) Frequency [5 marks]

- Q.5 (a) With the aid of a diagram, describe the energy changes which take place on a swinging pendulum. [5 marks]
- (b) A ball bearing is thrown vertically upwards from a height of 8 m with initial speed of 18 m/s. Calculate:
(i) Time taken to hit the ground
(ii) Maximum height attained. [5 marks]
- (c) (i) State Kepler's laws of motion [2 marks]
(ii) Show that angular velocity ω of a body moving in a circular path of radius r with a speed v is given by $V=r\omega$. [5 marks]
- (d) Give two ways in which stability of a car can be increased. [3 marks]

- Q.6 (a) (i) Draw a well labelled diagram of a gold leaf electroscope. [1 mark]
(ii) Describe how two identical metal balls may be charged positively and simultaneously by induction. [3 marks]
- (b) (i) State Coulomb's law [3 marks]
(ii) A point charge A and B of charges 2×10^{-4} C and 3×10^{-3} C are placed 2×10^{-2} m apart, Calculate the repulsive force between the charges. [4 marks]
- (c) A Battery of emf 24 V made of two cells; each of internal resistance 0.4Ω is connected to a network of resistors as shown in Fig.1

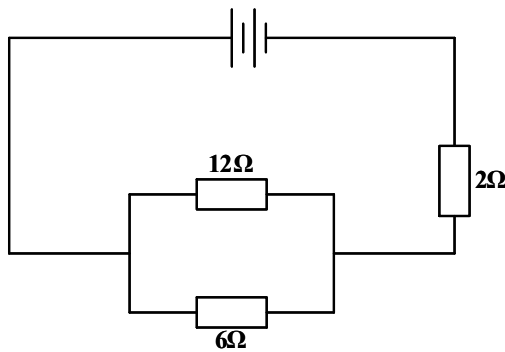

Calculate;

- (i) Total resistance [2 marks]
- (ii) Current Intensity [1 mark]
- (iii) Power dissipated by 6Ω resistor [3 marks]

(d) List two ways in which life of an accumulator can be prolonged [3 marks]

Q.7 (a) (i) What is meant by mutual induction? [1 marks]

(b) (i) Explain how an iron rod can be magnetised by single stroke method. [3 marks]

(ii) Draw a magnetic field pattern for two wires carrying current in the same direction. [3 marks]

(c) (i) Distinguish between a D.C motor and D.C generator. [3 marks]

(ii) Name three factors that affect efficiency of a transformer. [3 marks]

(d) (i) State advantages of A.C over D.C in power transmission and production [3 marks]

(ii) Briefly explain how power losses during transmission can be reduced. [4 marks]

Q.8 (a) (i) Draw a well labelled diagram of a Cathode Ray Oscilloscope (C.R.O) [5 marks]

(ii) State the function of each of the parts you have labelled in a(i) [6 marks]

(b) Give two uses of a Cathode Ray Oscilloscope [2 marks]

(c) A Cathode Ray Oscilloscope with time base switched on is connected across a power supply.

The wave format shown in Fig. 2 is obtained.

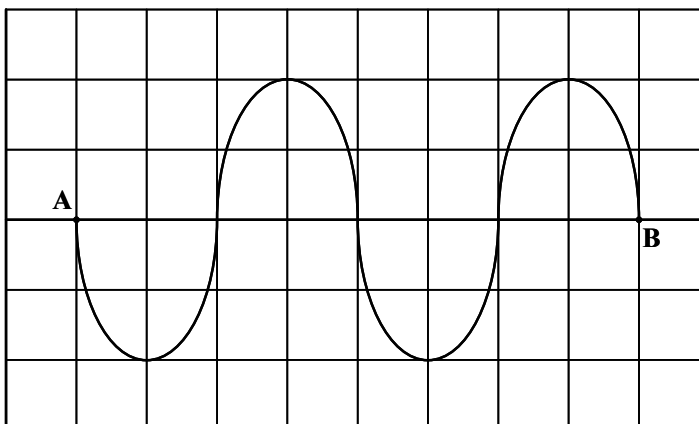

Distance between each line is 1cm

- (i) Find the amplitude of the voltage generated if the voltage gain is $5\text{V}/\text{cm}^{-1}$ [3 marks]
- (ii) Calculate the frequency of the power source if the time-base setting on the C.R.O is $5 \times 10^{-3} \text{ s cm}^{-1}$. [4 marks]

END



**Republic of South Sudan
Ministry of General Education & Instruction
Secretariat of Examinations**

**041/1
Physics
Paper One
3 hours**

SOUTH SUDAN CERTIFICATE OF SECONDARY EDUCATION EXAMINATIONS

Nov/Dec 2012

**PHYSICS
PAPER ONE**

TIME: 3 HOURS

NAME OF CANDIDATE

INDEX NUMBER.....SIGNATURE

INSTRUCTIONS

1. This paper consists of two sections: A and B. Section A contains 40 multiple choice questions which carry 40 marks. Section B contains 10 structured questions which carry 60 marks.
2. A candidate is required to answer all questions on the question paper.
3. Answers to Section A are to be written in the boxes provided on the right of each question and those in Section B in the spaces provided on the question paper.
4. Where necessary, use the following constants:

acceleration due to gravity (g)	= 10 ms ⁻²
speed of light	= 3 x 10 ⁸ ms ⁻¹
specific heat capacity of water	= 4200 J kg ⁻¹ K ⁻¹
charge on electron	= 1.6 x 10 ⁻¹⁹ C
mass of electron	= 9.1 x 10 ⁻³¹ kg

Section A: (40 marks)

1. All measurements in physics are related to the three fundamental physical quantities of

- A. length, density and time.
- B. length, mass and density.
- C. length, mass and time.
- D. density, volume and time.

2. Which one of the following statements defines power?

- A. Product of force and distance.
- B. Rate of energy transfer.
- C. Ratio of force per unit area.
- D. Product of force and time.

3. A pinhole camera forms a blurred image when

- A. the pinhole is small.
- B. the pinhole is large.
- C. the interior surface is darkened.
- D. the pinhole and screen are too close.

4. A local FM station broadcasts at a wavelength of 225 metres. What is the frequency of the radio wave?

- A. 1.3×10^6 Hz
- B. 1.3×10^{-6} Hz
- C. 3.0×10^6 Hz
- D. 3.0×10^{-6} Hz

5. The volume of a fixed mass of gas at constant pressure is 500 cm^3 at temperature of 27°C . What will be the volume at 42°C ?

- A. 525 cm^3
- B. 527 cm^3
- C. 300 cm^3
- D. 315 cm^3

6. The type of friction which slows down motion is

- A. viscosity.
- B. static friction.
- C. limiting friction.
- D. sliding friction.

7. A force of 20 N acts on a block of weight 40 N placed on a rough table as shown in Figure 1 below.

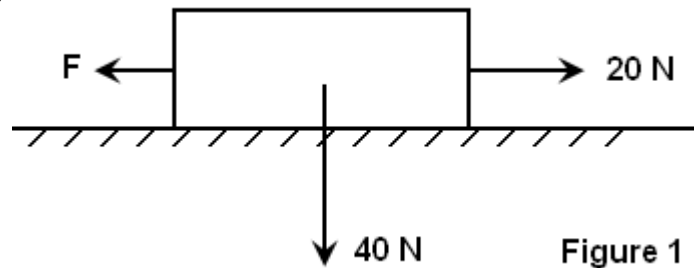

Find the effective force if the coefficient of friction is 0.2.

- A. 8 N
- B. 10 N
- C. 12 N
- D. 36 N
8. Concrete is a material obtained by a proportional mixing of
- A. cement, sand and sisal.
- B. cement, sand, gravel and water.
- C. cement, sand and alloys.
- D. cement, gravel and alloys.
9. A concave mirror produces a real image 1 cm tall of an object 2.5 mm tall placed 5 cm from the mirror. Calculate the focal length of the mirror.
- A. 20 cm
- B. 15 cm
- C. 5 cm
- D. 4 cm
10. What is the linear magnification of the mirror in Question 9 above?
- A. 4
- B. -4
- C. 0.4
- D. -0.4
11. Which of the following phenomena is NOT explained by the domain theory of magnetism?
- A. demagnetization
- B. magnetic saturation
- C. breaking a magnet
- D. magnetic screening

12. An X-ray tube operates with a potential difference of 100 kV between the cathode and the anode. The tube current is 10 mA. Calculate the rate at which energy is transferred in the target of the X-ray tube.

- A. 10 W
- B. 50 W
- C. 1000 W
- D. 100 W

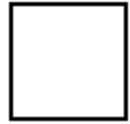

13. A mass of 5 kg is supported by two identical spiral springs of spring constant 1 N/mm as shown in Figure 2. Find the compression produced by the springs.

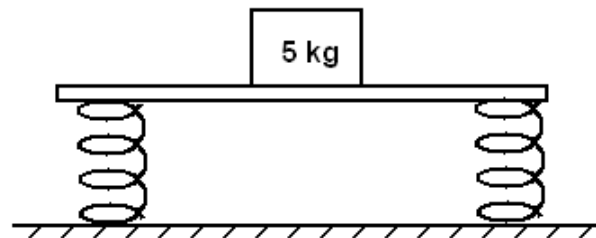

Figure 2

- A. 50 mm
- B. 25 mm
- C. 2 mm
- D. 5 mm



14. A white light is incident on a glass prism as shown in Figure 3 below.

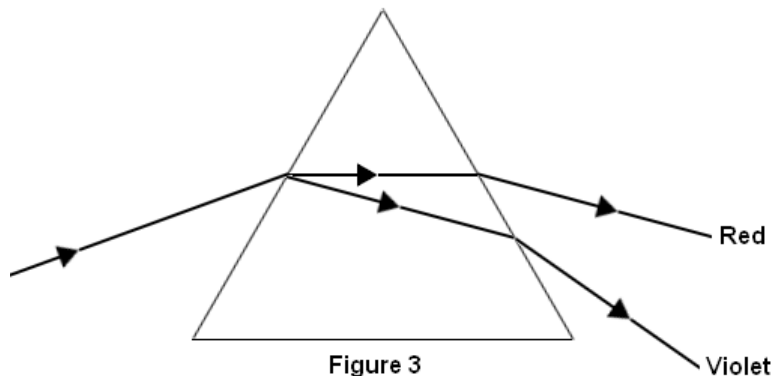

Figure 3

This result shows that

- A. red is deviated most.
- B. violet light is least deviated.
- C. yellow light is not deviated.
- D. white light is a mixture of colours.



15. The temperature of 500 g of a certain metal is raised to 100°C and it is then placed in 200 g of water at 15°C. If the final steady temperature rises to 21°C, calculate the specific heat capacity of the metal.

- A. 128 J kg⁻¹ K⁻¹
- B. 300 J kg⁻¹ K⁻¹
- C. 182 J kg⁻¹ K⁻¹
- D. 256 J kg⁻¹ K⁻¹

16. A radioactive substance X decays to a stable atom Y by emission of an alpha particle as shown in the equation below.

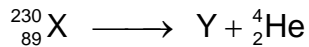

The atomic mass and atomic number of Y are

- | | Atomic mass | Atomic number |
|----|-------------|---------------|
| A. | 226 | 90 |
| B. | 226 | 88 |
| C. | 234 | 87 |
| D. | 226 | 87 |

17. Pressure in a liquid

- (i) increases with depth.
 - (ii) depends on cross-section area.
 - (iii) acts equally in all directions.
- A. (i) only
 - B. (i) and (ii) only
 - C. (i) and (iii) only
 - D. (i), (ii) and (iii)

18. A racing cyclist starts from rest and accelerates uniformly to a velocity of 20 ms⁻¹ in 4 s. What is the distance covered in the 4 s?

- A. 80 m
- B. 40 m
- C. 20 m
- D. 5 m

19. A man makes a loud sound and hears the echo of the sound after 1.25 s. If the speed of sound in air is 330 ms⁻¹, calculate the distance between the man and the object causing the echo.

- A. 275 m
- B. 396 m
- C. 198 m
- D. 550 m

20.

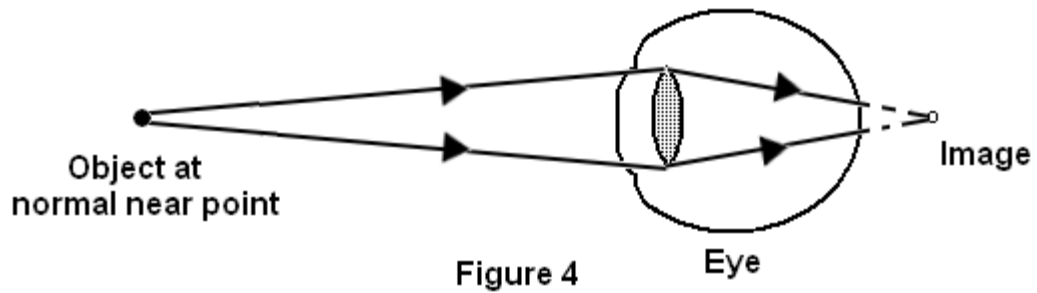

Which defect of vision is shown in Figure 4 above?

- A. long sightedness
- B. short sightedness
- C. accommodation
- D. long eyeball

21. Which one of the following is NOT a tool for measuring radiation?

- A. Geiger-Müller tube
- B. cloud chamber
- C. spectrometer
- D. photographic film

22. A car travelled from town A to town B 200 km east of A in 3 hours. The car then changed direction and travelled a distance of 150 km due north from B to C in 2 hours. Calculate the average speed of the car for the whole journey.

- A. 40 kmh^{-1}
- B. 70 kmh^{-1}
- C. 71 kmh^{-1}
- D. 75 kmh^{-1}

23. Which one of the following electromagnetic waves can be detected by using a thermopile?

- A. radio waves
- B. visible light
- C. ultraviolet rays
- D. infrared rays

24. "A transistor is an amplifier." This means that small change in the input voltage produces a

- A. small change in the output voltage.
- B. half-wave rectification.
- C. full-wave rectification
- D. large change in output voltage.

25. A moving-coil galvanometer which gives full-scale deflection with 0.005 A is converted to a voltmeter reading up to 5 V, using an external 975 Ω resistance. What is the resistance of the meter?

- A. 25 Ω
- B. 20 Ω
- C. 5 Ω
- D. 10 Ω

26. A parallel plate capacitor of capacitance 1000 μF carries a charge of 1.2×10^{-2} C. Determine the potential difference (p.d.) across the plates of the capacitor.

- A. 1200 V
- B. 1000 V
- C. 12 V
- D. 60 V

27. A ship made of steel floats in water because

- A. its average density is less than that of water.
- B. its average density is greater than that of water.
- C. steel is denser than water.
- D. steel is less dense than water.

28. Oxygen is compressed at constant temperature until its pressure rises from 82 cmHg to 140 cmHg. If the final volume of the oxygen is 50 cm^3 , find the initial volume of the oxygen.

- A. 29 cm^3
- B. 85 cm^3
- C. 850 cm^3
- D. 229.6 cm^3

29. An alternating e.m.f. of 240 V is applied to a step-up transformer having 200 turns on its primary coil and 4,000 turns on its secondary coil. What is its secondary e.m.f.?

- A. 960 V
- B. 480 V
- C. 4800 V
- D. 3333 V

30. Which one of the following quantities determines the quality of sound?

- A. fundamental frequency
- B. beats
- C. pitch
- D. overtones

31. A lens camera is used to take a photograph of a distant building. A well-focused image is formed on the film. The lens of the camera is 6 cm from the film. What is the focal length of the lens?

- A. 0.2 cm
- B. 6 cm
- C. -6 cm
- D. -0.2 cm

32. A cyclist going round a curve leans inwards in order to

- A. provide the necessary centripetal force.
- B. enjoy the motion.
- C. provide the centrifugal force.
- D. slow down the speed.

33.

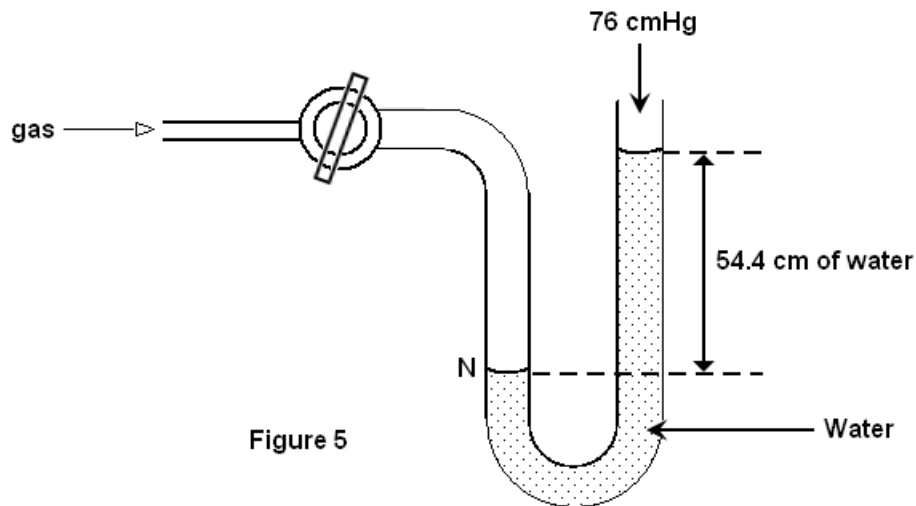

Figure 5

When the tap of the manometer in Figure 5 above is opened, the difference in level of water in the two arms of the manometer is 54.4 cm. What is the pressure at point N when the atmospheric pressure is 76 cmHg?

[density of water = 1000 kg m^{-3} ; density of mercury = $13,600 \text{ kg m}^{-3}$]

- A. 80 cmHg
- B. 72 cmHg
- C. 40 cmHg
- D. 86 cmHg

34. 600 g of water flows through a tube of uniform cross-section 20 cm^2 in 10 s. Calculate the rate of flow of water in $\text{m}^3 \text{ s}^{-1}$ if the density of water is 1000 kg m^{-3} .

- A. $2 \times 10^{-5} \text{ m}^3 \text{ s}^{-1}$
- B. $2 \times 10^5 \text{ m}^3 \text{ s}^{-1}$
- C. $6 \times 10^{-5} \text{ m}^3 \text{ s}^{-1}$
- D. $6 \times 10^5 \text{ m}^3 \text{ s}^{-1}$

35. The following are good conductors of electricity except

- A. metals
- B. pure water
- C. earth
- D. graphite

36. A pupil was given a mercury thermometer which was not sensitive enough. Which part of the thermometer would you advise the pupil to decrease if a more sensitive thermometer was to be made?

- A. the diameter of the capillary
- B. the volume of the bulb
- C. the radius of the bulb
- D. the thickness of the stem wall

37.

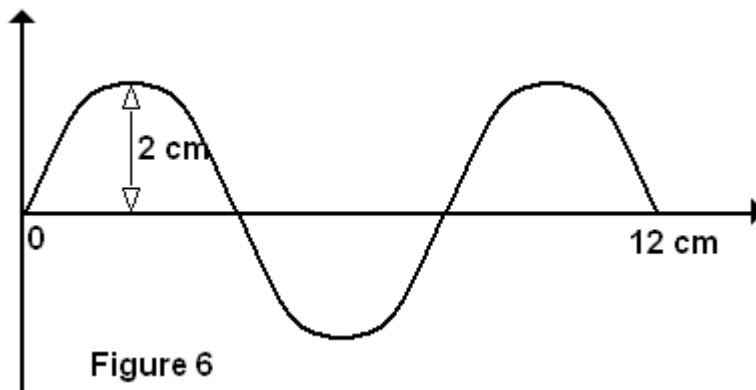

What is the wavelength shown in Figure 6 above?

- A. 2 cm
- B. 8 cm
- C. 10 cm
- D. 12 cm

38.

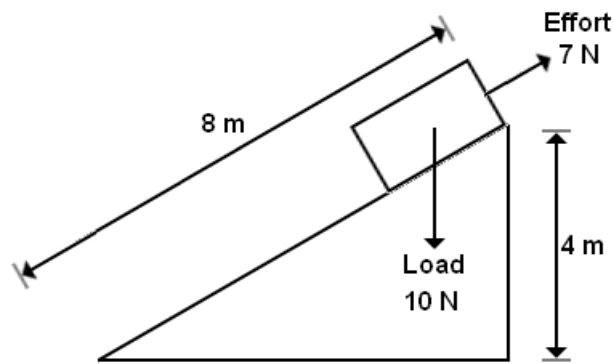

Figure 7

A load of 10 N is pulled up an inclined plane as shown in Figure 7 above. The velocity ratio is

- A. 2
- B. 12
- C. 6.9
- D. 1.4

39. The Figure 8 shows a beam of electrons directed to pass between the poles of a magnet.

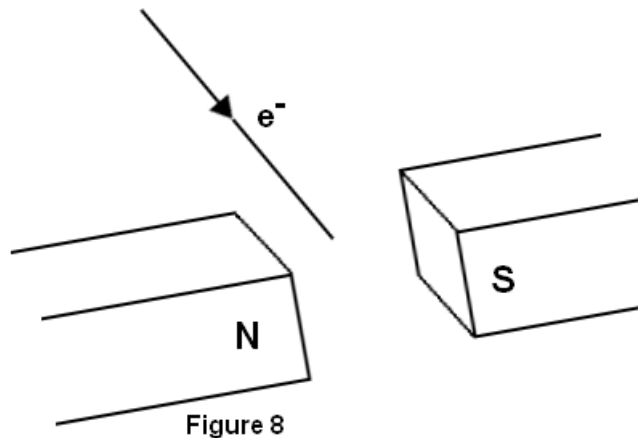

Figure 8

The electron beam would be

- A. deflected towards the south pole.
- B. reflected backwards.
- C. slowed down.
- D. deflected downwards.

40. An electron is ejected from the surface of a metal with kinetic energy of 2.24×10^{-19} J. What is the energy of the electron in electron volts?

- A. 3.2 eV
- B. 1.6 eV
- C. 2.24 eV
- D. 1.4 eV

Section B: (60 marks)

41. (a) (i) Define the term surface tension.

.....
.....(1 mark)

(ii) Give two ways of reducing surface tension.

.....
.....(2 marks)

(b) (i) Explain why water wets a glass surface.

.....
.....
.....
.....(2 marks)

(ii) Why does a well-constructed house have a damp course inserted between the wall bricks just above the ground?

.....
.....(1 mark)

42. (a)

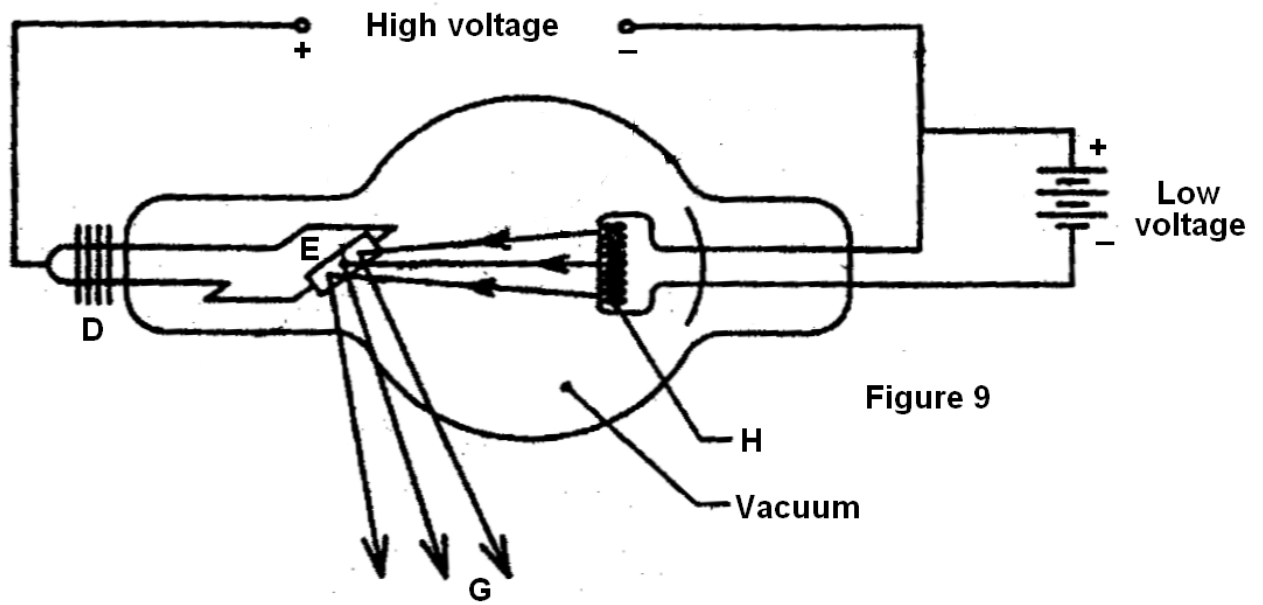

Figure 9

The diagram in Figure 9 above shows a hot cathode X-ray tube.

(i) Name the parts labelled (3 marks)

D

E

H

(ii) What is the purpose of the high voltage?

.....
.....(1 mark)

(b) Explain why X-ray tubes are highly evacuated.

.....
.....(1 mark)

(c) State two uses of X-rays.

.....
.....(1 mark)

43. (a) What is meant by the refractive index of a medium?

.....
.....
.....(1 mark)

(b)

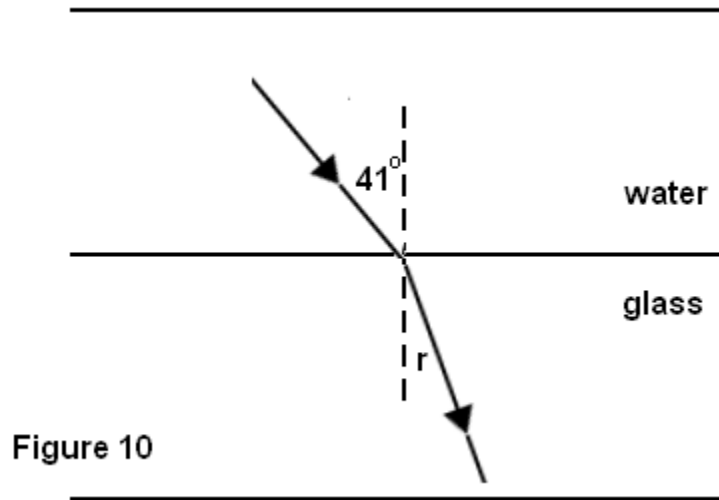

A ray of light is incident on the water-glass boundary at an angle of 41° as shown in Figure 10. Calculate the angle of refraction r if the refractive indices of glass and water are 1.50 and 1.33 respectively.

.....
.....
.....
.....
.....
.....(3 marks)

(c) State any two applications of total internal reflection.

.....
.....(2 marks)

44. (a) State Charles' Law.

.....
.....(1 mark)

(b) The pressure of a given mass of gas at constant volume at a temperature of 100°C is 600 mmHg. Calculate the pressure if the temperature falls to 27°C .

.....
.....
.....
.....
.....
.....(3 marks)

(c) Use the axes below to draw a sketch graph of volume against pressure for an ideal gas. (2 marks)

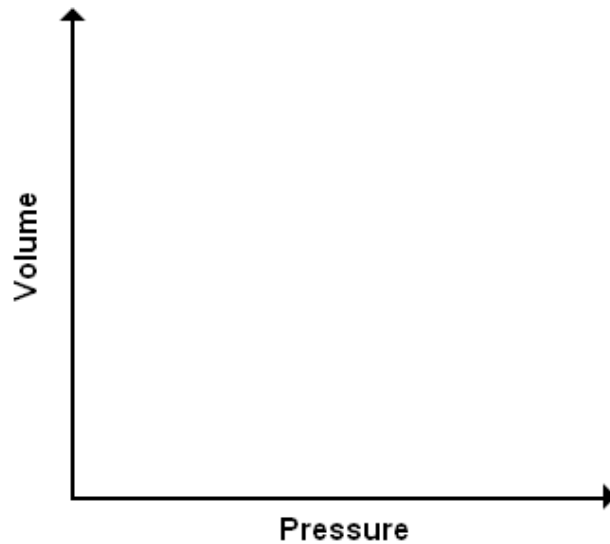

45. (a) Define pressure and state its S.I. units.

.....
.....
.....(2 marks)

(b) A cuboid of mass 5 kg has dimensions of 4 cm x 6 cm x 8 cm. Calculate the maximum pressure it can exert when placed on a table giving your answer in S.I. units.

.....
.....
.....
.....
.....
.....
.....(4 marks)

46. (a) State any two factors which determine the magnitude of the e.m.f. induced in a coil rotating in a magnetic field.

.....
.....(2 marks)

(b) Explain why soft iron is preferred to steel in making electromagnets.

.....
.....(2 marks)

(c) Mention two ways of making magnets.

.....
.....(2 marks)

47. (a) What is meant by the efficiency of a machine?

.....
.....(1 mark)

(b) A system of levers with a velocity ratio of 25 overcomes a resistance of 3300 N when an effort of 165 N is applied to it. Calculate

(i) the mechanical advantage of the system.

.....
.....
.....
.....(2 marks)

(ii) its efficiency.

.....
.....
.....
.....
.....(3 marks)

48. (a) Define electromagnetic waves.

.....
.....
.....(1 mark)

(b) State any two properties of electromagnetic waves.

.....
.....
.....(2 marks)

(c) Calculate the frequency of red light of wavelength 7×10^{-7} m.

.....
.....
.....(3 marks)

49. (a) Define

(i) virtual image

.....
.....(1 mark)

(ii) real image

.....
.....(1 mark)

(b) An object of height 20 cm is placed at a distance of 30 cm from a concave mirror of focal length 10 cm. Find by scale drawing the nature and position of the image.

(Use the squared paper on next page to answer this question.)

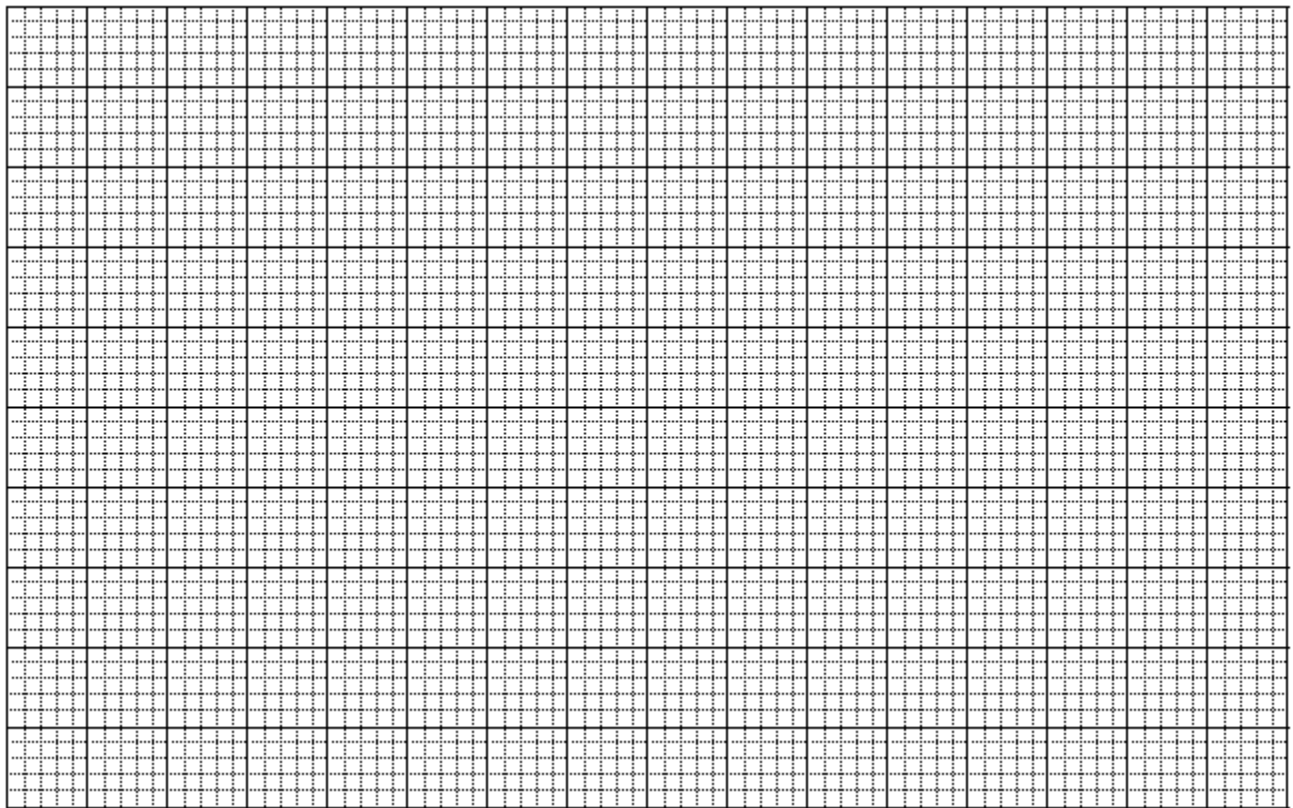

(4 marks)

50. (a) What is uniform acceleration?

.....
.....(1 mark)

(b) A car initially travelling at 20 ms^{-1} is accelerated for 10 s at 2 ms^{-2} . Calculate the total distance covered during this time.

.....
.....
.....
.....
.....
.....
.....(3 marks)

(c) Explain why a passenger in a vehicle jerks forward when the vehicle suddenly stops.

.....
.....
.....(2 marks)

[END]



Republic of South Sudan
Ministry of General Education & Instruction
Secretariat of Examinations

041/2
PHYSICS
PAPER TWO
3 hours

SOUTH SUDAN CERTIFICATE OF SECONDARY EDUCATION EXAMINATIONS

NOV/DEC, 2012

PHYSICS
PAPER TWO

TIME: 3 HOURS

INSTRUCTIONS

Read the instructions carefully before answering any question.

- 1. Attempt any FIVE questions in this paper.**
- 2. All answers must be written in the answer booklet provided.**
- 3. Where necessary, use the following constants:**

- *acceleration due to gravity (g)* $= 10 \text{ ms}^{-2}$
- *speed of light* $= 3 \times 10^8 \text{ ms}^{-1}$
- *specific heat capacity of water* $= 4200 \text{ J kg}^{-1} \text{ K}^{-1}$
- *charge on electron* $= 1.6 \times 10^{-19} \text{ C}$
- *mass of electron* $= 9.1 \times 10^{-31} \text{ kg}$
- *Planck's constant (h)* $= 6.6 \times 10^{-34} \text{ J s}$

Answer any FIVE questions.

1. (a) Distinguish between weight and mass of a body. (4 marks)
- (b) (i) What is meant by centre of gravity? (1 mark)
- (ii) Describe an experiment to determine the centre of gravity of an irregular lamina. (4 marks)
- (c) A body attached to a string is swung in a vertical circular path in air as shown in Figure 1.

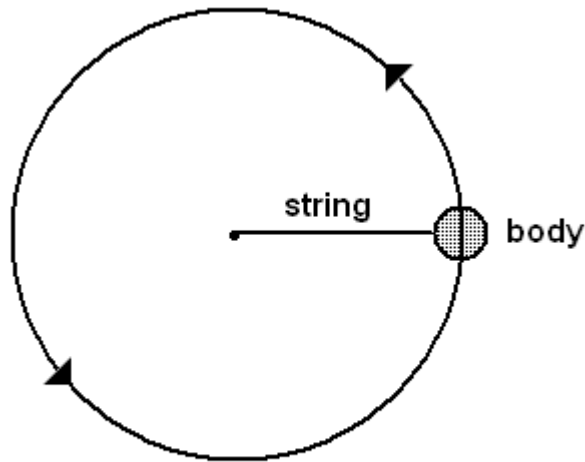

Figure 1

- Copy the above diagram and on it indicate and name all the forces acting on the body if the body is moving in an anticlockwise direction. (3 marks)
- (d) (i) Sketch the distance-time graph for a body falling freely from rest. (2 marks)
- (ii) A ball of mass 0.25 kg is dropped from rest at a height of 20 m above the ground. Calculate the time it takes to reach the ground. (3 marks)
- (iii) If the ball in 1 d (ii) above bounced once on hitting the ground and lost 20% of its original energy, calculate the maximum height the ball reached again. (3 marks)
2. (a) Describe an experiment to show that light travels in a straight line. (4 marks)
- (b) An object of height 4 cm is placed 5 cm away from a pinhole camera. The screen is 1 cm from the pin hole.
- (i) Draw to scale a ray diagram to show the formation of the image by the pinhole camera. (4 marks)
- (ii) What is the nature of the image? (1 mark)

(iii) Find the magnification. (2 marks)

(c) What are the similarities and differences of a pinhole camera and a lens camera? (6 marks)

(d) With the help of a ray diagram, explain the characteristics of images formed by a plane mirror. (3 marks)

3. (a)

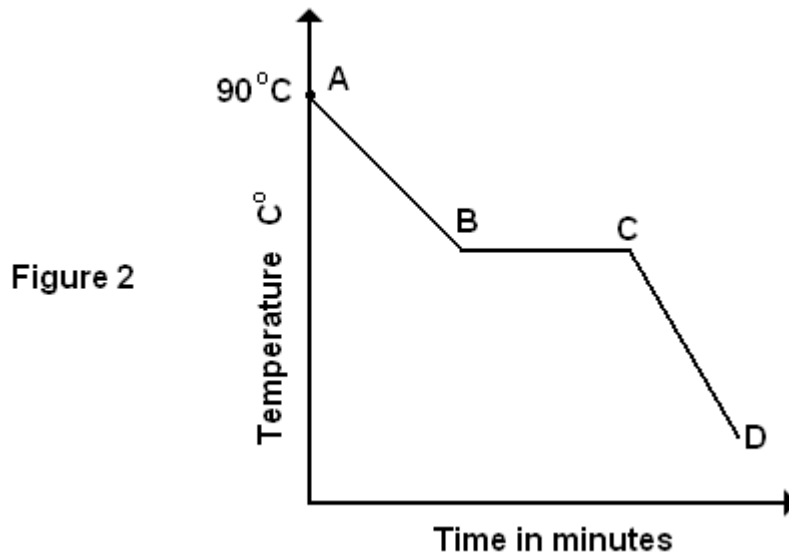

Figure 2 shows a cooling curve for a substance which is in liquid form at 90°C .

(i) In what states is the substance over the regions AB, BC and CD of the curve? (3 marks)

(ii) Explain why the temperature remains constant between B and C. (2 marks)

(b) (i) Define specific heat capacity. (2 marks)

(ii) 1 kg of water at 40°C is placed in an aluminium can of mass 0.5 kg at 18°C . The temperature of the water drops to 38°C . Calculate the specific heat capacity of the aluminium. (4 marks)

(c) (i) What is a saturated vapour? (1 mark)

(ii) What happens when a saturated vapour is compressed? (2 marks)

(iii) Explain why saturated vapour does not obey Charles' Law or Boyle's Law. (2 marks)

(iv) Sketch a graph showing the variation of pressure with temperature of a saturated vapour. (4 marks)

4. (a) Differentiate between longitudinal and transverse waves giving one example of each. (3 marks)

(b) Figure 3 shows circular waves propagating towards a plane reflector.

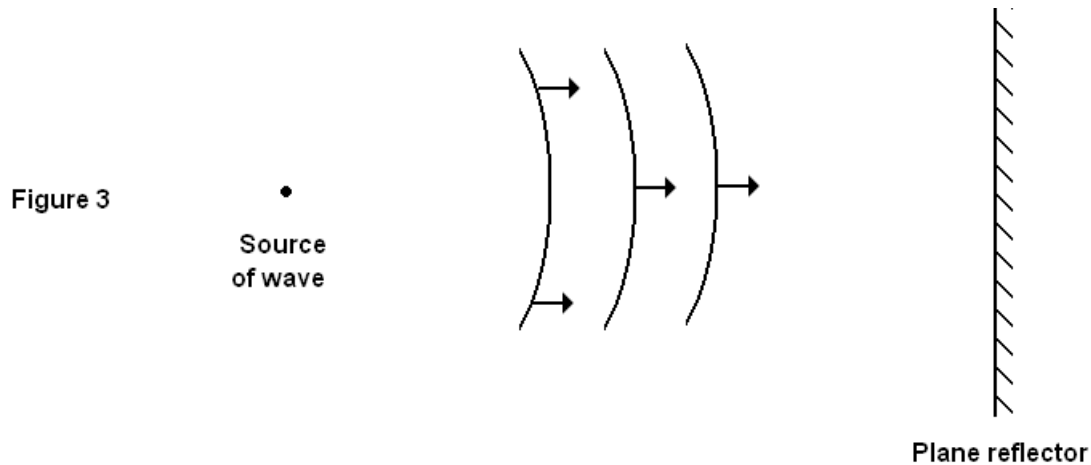

(i) Draw a diagram to show how the waves will be reflected. (3 marks)

(ii) Calculate the frequency of the waves if their velocity and wavelength are 5 ms^{-1} and 0.5 m respectively. (3 marks)

(c) (i) What is a standing wave? (1 mark)

(ii) State the conditions for formation of standing waves. (2 marks)

(d) (i) Describe a simple experiment to measure the speed of sound in air by echo method. (4 marks)

(ii) A man standing midway between two cliffs makes a loud sound. He hears the first echo after 3 s . Calculate the distance between the two cliffs if the velocity of sound in air is 330 ms^{-1} . (4 marks)

5. (a) (i) Define the term velocity. (1 mark)

(ii) Sketch a velocity-time graph for a body moving with uniform velocity. (2 marks)

- (b) A vehicle travelling at a velocity of 90 km h^{-1} is uniformly brought to rest in 20 s.
- Calculate the deceleration of the vehicle. (4 marks)
 - If the vehicle had been travelling at the velocity of 90 km h^{-1} for 60 s, calculate the total distance travelled before it finally stopped. (4 marks)
- (c) What do you understand by angular displacement? State its S.I. units. (2 marks)
- (d) A wheel of a car of radius 20 cm is rotating at a frequency of 20 Hz. Calculate;
- its angular velocity. (3 marks)
 - the force turning the wheel if its mass is 10 kg. (4 marks)
6. (a) Define the following terms:
- volt (1 mark)
 - electrical resistance (1 mark)

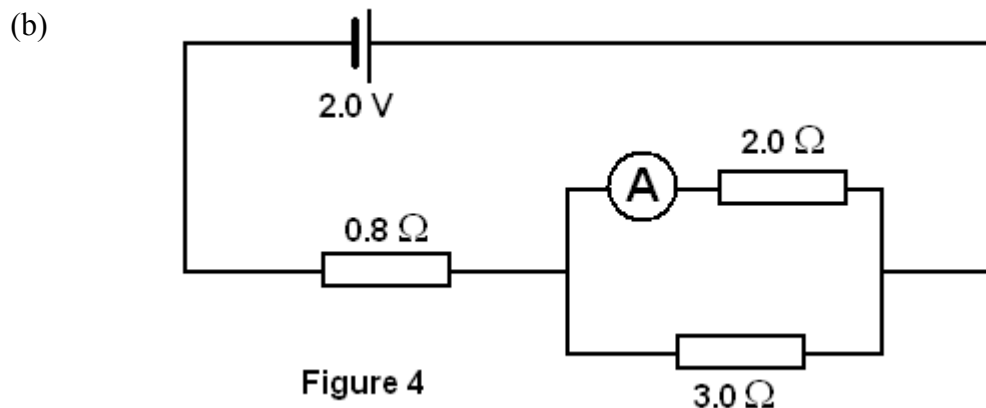

- A battery of e.m.f. 2.0 V and of negligible internal resistance is connected as shown in Figure 4. Find the reading of ammeter A. (5 marks)
- (c) Describe a simple experiment to measure the internal resistance of a cell. (6 marks)
- (d) (i) What is meant by capacitance of a capacitor? (1 mark)
- (ii) State the factors affecting the capacitance of a capacitor. (3 marks)
- (e) When a capacitor is connected to a battery of e.m.f. 12 V, the charge stored on each plate is 0.06 mC. Calculate the capacitance of the capacitor. (3 marks)

7. (a) State the laws of electromagnetism. (1 mark)
- (b) Explain the following terms:
- (i) magnetic saturation (1 mark)
- (ii) demagnetisation (1 mark)
- (c) The diagram in Figure 5 shows the main features of a galvanometer.

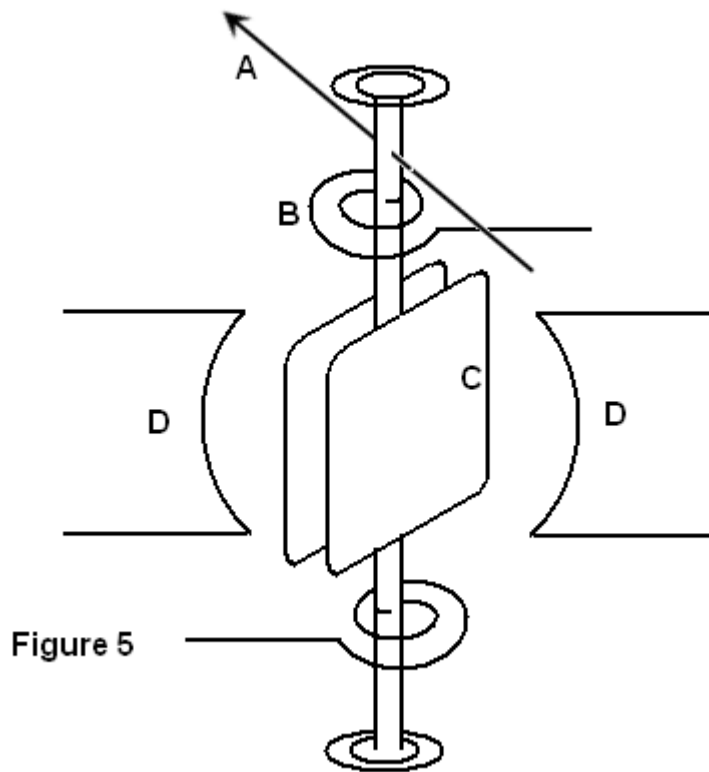

- (i) Label parts A, B C and D. (2 marks)
- (ii) Explain how this instrument is able to indicate steady value of current. (5 marks)
- (iii) How could the sensitivity of the galvanometer be increased? (3 marks)
- (iv) Why is D curved? (1 mark)
- (d) Explain what would be observed if the terminals of the galvanometer were connected to a low frequency. (2 marks)

- (e) The resistance of a galvanometer is 10 ohms and a current of 2.5 mA produces a full-scale deflection. Calculate the value of the resistance that should be connected in series with the meter so that it gives a full-scale deflection when a potential difference of 3V is applied. (4 marks)
8. (a) Explain the term photoelectric effect. (2 mark)
- (b) (i) State the factors which affect photoelectric effect. (4 marks)
- (ii) Zinc has a work function of 4.27 eV. Find the maximum wavelength of light that is needed to cause photoelectric emission. (4 marks)
- (c) (i) With the aid of a well-labelled diagram, explain the working of a cathode ray tube. (6 marks)
- (ii) State four uses of a cathode ray tube. (4 marks)

[END]



**GOVERNMENT OF SOUTHERN SUDAN
MINISTRY OF EDUCATION
EXAMINATIONS SECRETARIAT**



**SOUTHERN SUDAN CERTIFICATE OF SECONDARY EDUCATION (S.S.C.S.E)
EXAMINATIONS**

Nov./Dec. 2010

**042/2 CHEMISTRY
PAPER TWO
2 HOURS**

NAME (CAPITAL LETTERS):

INDEX NUMBER **SIGNATURE**.....

INSTRUCTIONS

1. The paper consists of two sections A and B.
2. Section A has 10 compulsory structured questions(50 marks) and Section B has 5 semi-structured questions of which candidates are required to answer any two (20 marks).
3. All answers to questions in Section A and B must be written in the spaces provided on the question paper.
4. Illegible handwriting and untidy work may lead to loss of marks.

FOR EXAMINER'S USE ONLY														
1	2	3	5	6	7	8	9	10	11	12	13	14	15	TOTAL

SECTION A (50 MARKS)

Answer all questions in this section.

1. (a) Define Fractional distillation. 1 mark

- (b) Briefly describe how a mixture of ethanol and water can be separated by Fractional distillation. 4 marks

2. The apparatus shown in figure 1 is used for preparing chlorine gas from concentrated hydrochloric acid and substance X.

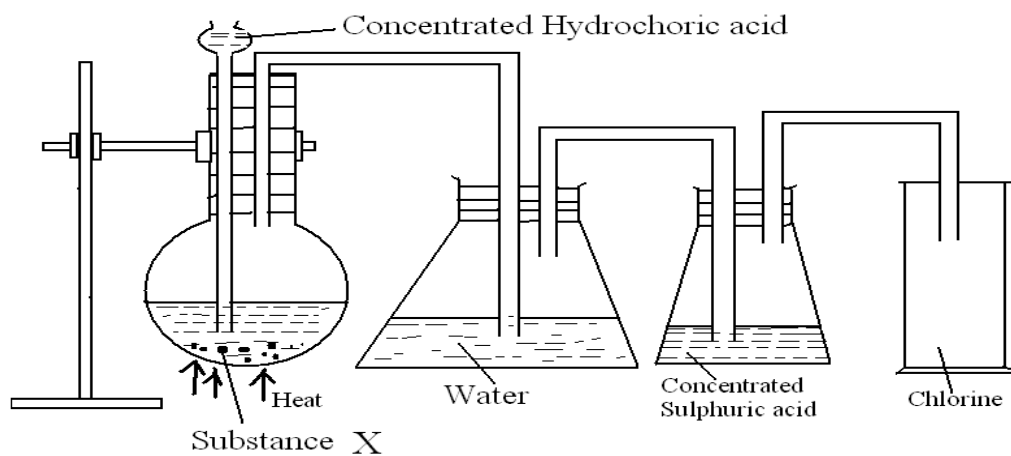

FIGURE 1

(a) (i) Name substance X. _____ ½ mark

(ii) What is the role of water? ½ mark

(iii) State the role of concentrated sulphuric acid. 1 mark

(iv) Write the equation for the reaction taking place in the flask. 1 mark

(b) Chlorine water was exposed to sun light.

(i) State what was observed. 1 mark

(ii) Explain briefly your observation in (b) (i). 1 mark

3. (a) What is meant by the term molar solution? 1 mark

(b) 0.5 g of anhydrous sodium carbonate was dissolved in water to make 150 cm³ solution. Calculate:

(i) the mass of anhydrous sodium carbonate needed to make one litre of the solution. (C=12; O=16; Na=23). 2 marks

(ii) the morality of the solution.

2 marks

4. The atomic number of carbon and chlorine are 6 and 17 respectively.

(a) Draw a shell diagram to show the electronic structure of:

(i) Carbon

1 mark

(ii) Chlorine

1 mark

(b) Write the structural formula of the compound that can be formed between carbon and chlorine.

1 mrk

(c) Name the type of bond that exist in the compound in (b).

1 mark

(d) State whether the compound formed in (b) would conduct electricity or not. Give a reason for your answer.

1 mark

5. (a) The flow chart in Figure 2 shows the contact process.

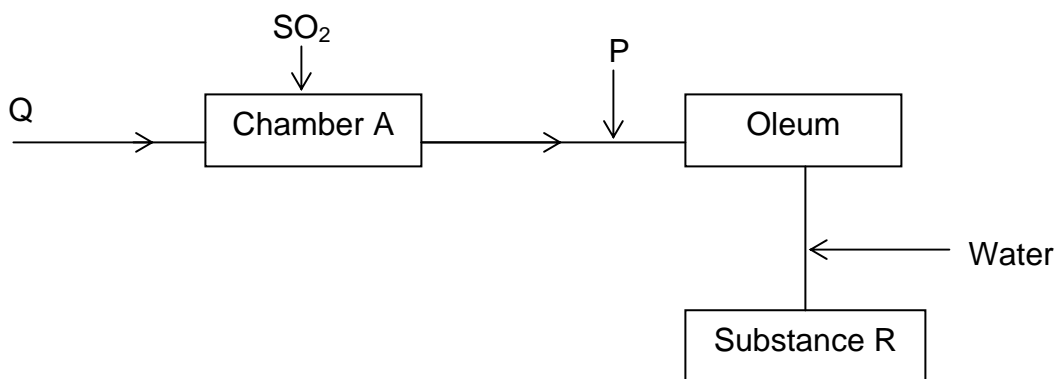

FIGURE 2

(i) Identify substances: Q, P, and R.

Q ½ mark

P ½ mark

R ½ mark

(ii) State the conditions under which the reaction in chamber A takes place.

½ mark

(ii) Explain why substance P was made to react with the products of reaction in chamber A to form oleum before water is added.

½ mark

(b) Concentrated sulphuric acid was added to sugar.

(i) State what was observed.

1½ mark

(ii) What property of sulphuric acid is shown by the reaction above?

1 mark

6. The table below shows the variation of atomic radius of some elements of period 3 of the Periodic table.

Elements	Na	Mg	Al	Si	P	S	Cl
Atomic radius (nm)	0.186	0.160	0.143	0.117	0.110	0.104	0.100

(a) (i) State the trend in the variation of the atomic radius of the elements on moving from left to right across the period.

1 mark

(ii) Explain the trend in your answer in a(i).

3 marks

(b) Give a reason as to why transition metals are good catalyst.

1 mark

7. Study the diagram in Figure 3 and answer the questions that follow.

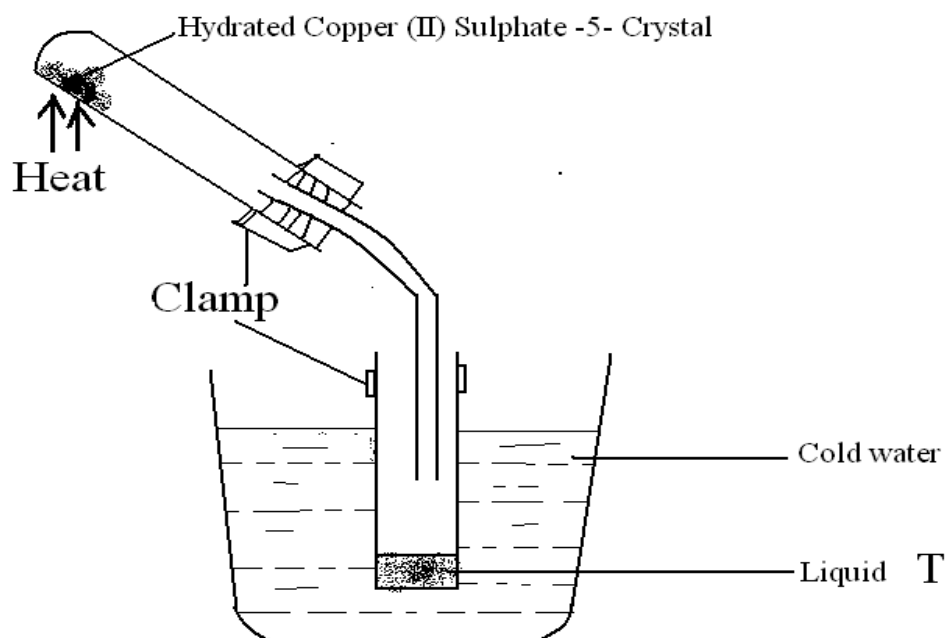

FIGURE 3

- (a) (i) State what is observed when the copper(II) sulphate -5-water crystals is gently heated. Explain your observation. 1 mark

- (ii) Name liquid T. ½ mark

- (iii) Write the equation for the reaction that took place. 1 mark

- (b) When 7.2 g of Sodium Carbonate, $\text{Na}_2\text{CO}_3 \cdot n\text{H}_2\text{O}$ was strongly heated, the mass of the residue was 2.7 g. Calculate the number of moles of water of crystallization (n). (H=1; C=12; O=16; Na=23). 2½ marks

8. (a) State the kinetic theory of matter. 1 mark

(b) Using kinetic theory explain why solids have definite size and shape but gases have no definite size and shape. 4 marks

9. (a) State the method of separation that can be used to separate a mixture of Copper(II) Sulphate and Lead(II) Sulphate. ½ mark

(b) Give a reason for your answer in (a) above 1 mark

(c) Using the method you have stated in (a); explain how a mixture of Copper(II) Sulphate and Lead (II) Sulphate can be separated. 3½ marks

10. (a) (i) Name the process by which soap is manufactured? ½ mark

(ii) State the major substances used in the manufacture of soap. 1½ mark

(b) (i) Briefly describe the process of manufacturing soap. 2 marks

(ii) State two advantages of non-soapy detergents over soap for laundry work. 1 mark

SECTION B

Answer any two questions.

11. (a) Write equation to show how carbon-monoxide can be prepared from Oxalic acid. 1 mark

- (b) In the space below, draw a labeled diagram to show how carbon monoxide can be prepared in the laboratory using oxalic acid. 5 marks

- (c) State what would be observed and write equation for the reaction that would occur when carbon monoxide is:

- (i) passed over heated Copper(II) oxide 2 marks

- (ii) burnt in air 2 marks

12. (a) Name the ore from which aluminum is extracted and write the formula of of the ore. 1 mark

(b) With the aid of a labeled diagram describe how aluminum can be extracted from the ore you named in (a)

7 marks

(c) Write equation for the reaction between aluminum and aqueous sodium hydroxide.

1 mark

(d) State two uses of aluminum.

1 mark

13. (a) Describe an experiment that can be used to determine the heat of combustion of ethanol. Draw a diagram to illustrate your answer.

7 marks

- (b) When 0.382 g of ethanol was burnt, the heat evolved raised the temperature of 100 g of water from 16.5⁰C to 43.5⁰C. Calculate the heat of combustion of ethanol.
(Specific heat capacity of water = 4,200 Jg⁻¹K⁻¹, (H=1; C=12; O=16)

3 marks

14. (a) Define the term electrode potential.

2 marks

- (b) With the aid of a well labeled diagram, describe electrode potential of Zinc.

4 marks

- (c) During the electrolysis of copper (II) sulphate solution using platinum electrodes, 56 cm³ of oxygen was evolved at s.t.p. Calculate the mass of copper deposited.
(Cu=64.5; 1 mole of gas at s.t.p. occupies 22.4 dm³)

4 marks

15. The table below shows some tests that were carried out on substance ,W, and the observations made. Substance, W, contains one cation and one anion.

- (a) Complete the table by filling in the deduction column.

TEST	OBSERVATION	DEDUCTION (5 MARKS)
1. Solid W was heated	A colourless gas which turned lime water milky was given off.	
2.(a) Dilute nitric acid was added to a small amount of W. 2.(b) The solution was divided into three parts, 1 st , 2 nd and 3rd.	(a)-effervescence occurred and a gas that turned lime water milky evolved.	
3. Excess aqueous Sodium hydroxide was added to the 1 st part of the acidic solution of W.	-blue precipitate was formed.	
4. Aqueous magnesium sulphate solution was added to the second part of the acidic solution of W.	-White precipitate was formed	
5. To the third part of the acidic solution of W was added excess aqueous ammonia hydroxide	-deep blue solution was formed.	

- (b) Identify the:
- (i) anion present in W. 1 mark
 - (ii) cation in W. 1 mark
- (c) Write;
- (i) Equation for the reaction in test (3). 2 marks

 - (ii) The formula of the deep blue solution formed in reaction (5) 1 mark

END



Republic of South Sudan
Ministry of General Education & Instruction
Secretariat of Examinations

042/2
CHEMISTRY
Paper 2
2 hours

SOUTH SUDAN CERTIFICATE OF SECONDARY EDUCATION (S.S.C.S.E)

EXAMINATIONS

CHEMISTRY
PAPER 2

TIME: 2 HOURS

NAME (CAPITAL LETTERS)

INDEX NUMBER SIGNATURE

INSTRUCTIONS

Read the instructions carefully before answering any question

- 1. This paper consists of two Sections: A and B. Section A has 10 structured questions and Section B has 5 semi-structured questions.*
- 2. Candidates are required to answer ALL questions in Section A, and any 2 questions in Section B.*
- 3. All answers to questions in both Sections must be written in the spaces provided.*
- 4. Use blue or black ballpoint pen only. Any drawing must be done in pencil.*
- 5. Illegible handwriting and untidy work leads to loss of marks.*

SECTION A: (50 Marks)

1. (a) State the percentage by volume of the following gases in air [1 mark]

(i) Oxygen

(ii) Carbon dioxide

(b) In an experiment, a certain volume of air was passed from syringe to syringe over heated copper turnings slowly and repeatedly until there was no change in the volume of the air in the syringe. The set-up was as shown in figure 1 below

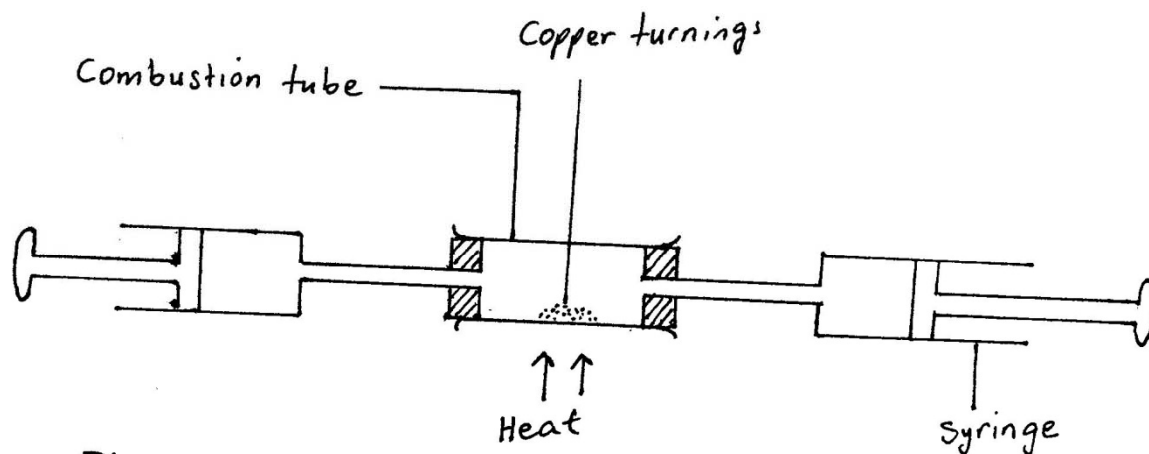

Fig. 1

(i) Explain why the air was passed over the copper turnings slowly and repeatedly [2 Marks]

.....
.....
.....

(ii) State what is observed in the combustion tube [1 Mark]

.....
.....
.....

(iii) Use the data below to calculate the percentage of oxygen in air:

Volume of air in syringe before the experiment = 10 cm³

Volume of air in syringe after the experiment = 7.9 cm³

.....

.....

.....[2 marks]

2. (a) Chlorine can be prepared from concentrated hydrochloric acid and substance X

(i) Name the substance X [1 Mark]

.....

.....

(ii) Write equation for the reaction leading to the formation of chlorine gas [1 Mark]

.....

.....

(b) Chlorine gas was passed through cold dilute sodium hydroxide solution

(i) State what was observed [1 Mark]

.....

.....

.....

.....

(ii) Write equation for the reaction that took place in (b) (i) above [1 Mark]

.....

.....

(c) State one use of chlorine [1 Mark]

.....

.....

3. (a) Define the term

(i) Standard solution [1 Mark]

.....
.....
.....

(ii) Molarity [1 Mark]

.....
.....
.....

(b) A solution of contains 43 g of substance XOH per litre. 25 cm³ of this solution required 30 cm³ of a 0.3 M sulphuric acid for complete neutralization.

(i) Calculate the number of moles of XOH that reacted [1 Mark]

.....
.....

(ii) Determine the molar mass of X [2 Marks]

.....
.....

4. The table below shows the properties of two chlorides A and B

Substance	Melting point(°C)	Electrical conduction(liquid)
A	2580	Good
B	-164	Poor

(a) State the type of bond present in

(i) A [1 Mark]

.....

(ii) B [1 Mark]

.....

(b) Explain in terms of bonding the differences in electrical conduction of the liquid chlorides in each compound [3 Marks]

.....
.....

5. Sulphur dioxide can be prepared in a laboratory using the set up apparatus shown in figure 2

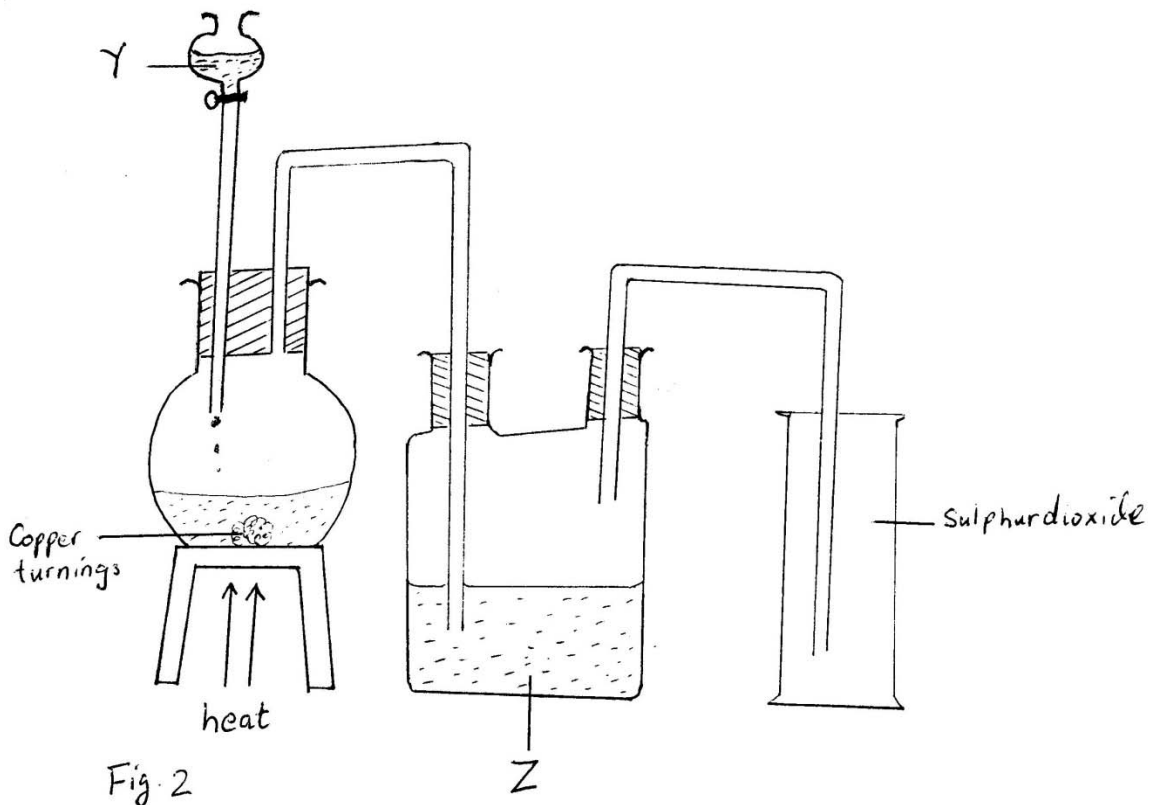

- Fig. 2
- (a) Identify substance
- (i) Y [1 Mark]
-
- (ii) Z [1 Mark]
-
- (b) State the purpose of solution Z [1 Mark]
-
-
- (c) Write the equation leading to the formation of sulphur dioxide gas [1 Mark]
-
-
- (d) Explain why the gas is collected by the method shown in the diagram above [1 Mark]

.....
.....

6. Atoms form ions by losing or gaining electrons.

a) i) Complete the blank spaces on the table below for the formation of aluminum and chloride ions [2 marks]

Atom	Electron arrangement	Ion	Electron arrangement
Al	2.8.3	Al^{+3}	
Cl	2.8.7		2.8.8

ii) Use this information to write the chemical formula for aluminum chloride

.....
..... [1 marks]

b) Caesium (Cs) has the atomic number 55 and is at the bottom of the Group I of the Periodic Table.

i. What is the valency of Caesium... [1 mark]

ii. Would you expect its melting point to be higher or lower than that of Potassium?

.....
Explain your answer..... [3 mark]

7. The graph below was obtained when a substance was heated and its temperature recorded at regular intervals

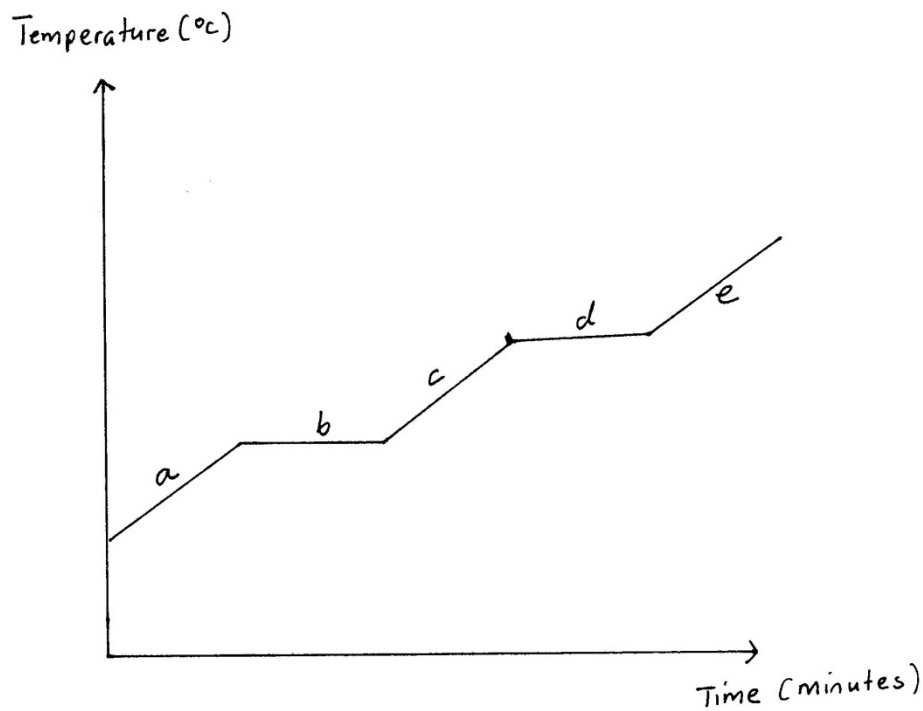

(a) (i) State whether the substance was pure or impure [1 Mark]

.....

(ii) Explain your answer in (a)(i) above [2 Marks]

.....

(b) What was the state of the substance in regions

(i) c [½ mark]

(ii) e [½ mark]

(c) Why did the temperature of the substance remain constant despite constant heating in the regions b and d? [1 Mark]

8. The table below shows the results obtained when soap solution was added to 10 cm³ of water samples A, B and C in separate containers.

	Before boiling			After boiling		
Sample of water	A	B	C	A	B	C
Volume of soap solution required for permanent lather(cm ³)	3	9	6	3	9	2

(a) Identify which sample was rain water, temporary hard water and permanent hard water(give reasons for your answer)

(i) Rain water [1Mark]

Reason [1 Mark]

(ii) Temporary hard water [1 Mark]

Reason [1 Mark]

(iii) Permanent hard water [1/2 Mark]

Reason [1/2 Mark]

9. Figure 3 below shows how a mixture of water and paraffin can be separated

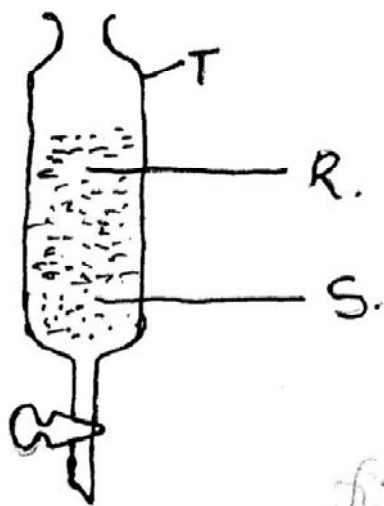

(a) Identify the Name T [1 Mark]

.....
.....
.....
.....

(b) Identify the substances labeled
(i) R [1 Mark]

(ii) S [1 Mark]

(c) State the principle by which the mixture of the two liquids are separated [2 Marks]

.....
.....
.....
.....

10. (a) Write the structured formula of ethene [1 Mark]

.....
.....

(b) Ethene is prepared by reacting ethanol with sulphuric acid. State the conditions for the reaction [1 Mark]

.....
.....

(c) Ethene gas was bubbled into bromine water in a beaker [1 Mark]
(i) State what was observed

.....
.....

(ii) Write the equation for the reaction [1 Mark]

.....
.....

(iii) State one use of ethanol..... [1 mark]

SECTION B: (20 marks) Answer only 2 Questions

11. (a) A substance M reacts with dilute hydrochloric acid to produce carbon dioxide gas [1 Mark]
(i) Identify M

.....
.....

(ii) Write equation for the reaction leading to the formation of carbon dioxide gas [1 Mark]

.....
.....

(b) In the space below, draw a labeled diagram of the apparatus you would use to prepare carbon dioxide in the laboratory [4 Marks]

(c) State what would be observed if carbon dioxide is bubbled through lime water for
(i) a short time [1 Mark]

.....
.....

(ii) a long time [1 Mark]

.....
.....

(d) Explain the observation in (c) (ii) above [3 Marks]

.....
.....

12. Sodium is extracted from its ore using the setup shown in figure 4 below

F4.

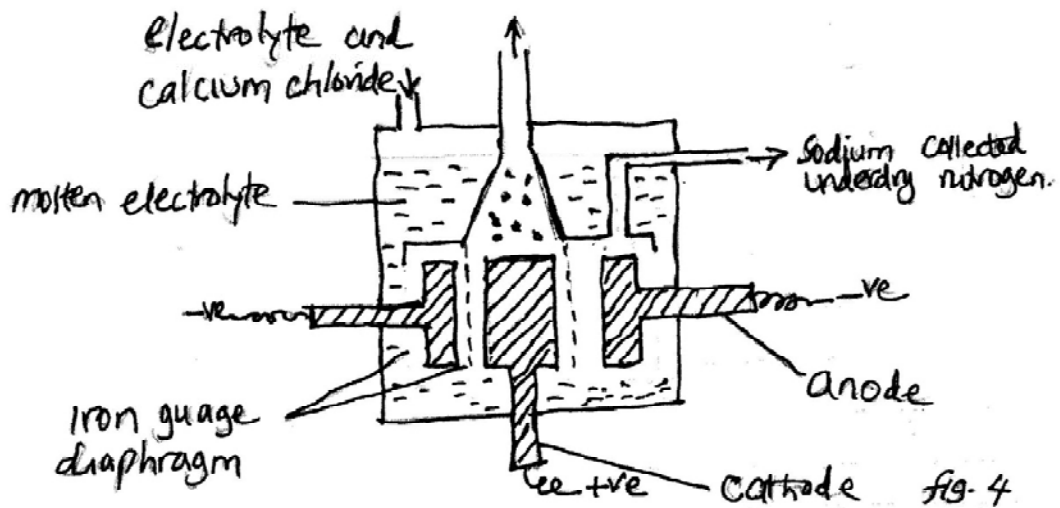

(a) Name the process by which sodium is extracted from its ore [1 Mark]

.....
.....

(b) Name the

(i) electrolyte [1 Mark]

.....
.....

(ii) material of which the cathode is made [1 Mark]

.....
.....

(c) Write the equation for the reaction that takes place at the

(i) cathode [1 Mark]

.....
.....

(ii) anode [1 Mark]

.....
.....

(d) What is the purpose of calcium chloride [2 Marks]

.....
.....

(e) State

(i) Why sodium is collected under dry nitrogen [2 Marks]

.....
.....

(ii) One use of sodium [1 Mark]

.....
.....

13. (a) Define the terms

(i) Heat of combustion [1 Mark]

.....
.....

(ii) Enthalpy [1 Mark]

.....
.....

(b) In an experiment to determine the heat of combustion of ethanol, the following results were collected

Temperature of water before heating = 25.0°C
Temperature of water after heating = 37.0°C
Initial mass of lamp before experiment = 85.30 g
Final mass of lamp after experiment = 84.80 g
Volume of water used = 200 cm³

(i) Calculate the mass of ethanol used [1 Mark]

.....
.....

(ii) amount of heat produced by burning the ethanol [3 Marks]

Density of water = 1 g/cm³, specific heat capacity of water = 4.2 J/g/K

.....
.....

(iii) heat of combustion of ethanol (C=12, H=1, O=16) [3 Marks]

.....
.....

(c) The actual value of heat of combustion of ethanol is – 1370 KJ/mol.
Suggest one reason why the value got in (b) (iii) above is less than this [1 Mark]

.....
.....

14. (a) Draw a diagram of a Danielle cell consisting of a zinc rod dipped in zinc solution and copper rod dipped in copper sulphate solution. The solution separated by a porous partition and the rods connected by a wire.

[3 Marks]

(b) Indicate on the diagram

(i) charges on each electrode

[1 Mark]

(ii) direction of electron flow in the wire

[1 Mark]

(c) Write equation for the

(i) reaction at the cathode

[1 Mark]

.....
.....

(ii) reaction at the anode

[1 Mark]

.....
.....

(iii) overall reaction

[1 Mark]

.....
.....

(d) If the reading on the voltmeter in the circuit was 1.1 V, calculate the energy in kilojoules(KJ) [2 Marks]

.....
.....
.....

15. (a) Name **one** reagent that can be used to distinguish the following ions in solution. State what would be observed in each case if each ion is reacted with the reagent

(i) Zn^{2+} and Al^{3+} [3 Marks]

.....
.....

(ii) Ca^{2+} and Pb^{2+} [3 Marks]

.....
.....

(iii) Cu^{2+} and Fe^{2+} [3 Marks]

.....
.....

(b) Name one reagent that reacts with CO_3^{2-} and SO_4^{2-} to show similar observations [1 Mark]

.....
.....

THE END



**Republic of South Sudan
Ministry of General Education & Instruction
Secretariat of Examinations**

**042/1
Chemistry
Paper 1
1½ Hours**

SOUTH SUDAN CERTIFICATE OF SECONDARY EDUCATION EXAMINATIONS

NOV/DEC, 2012

**CHEMISTRY
PAPER 1**

TIME: 1 HOUR 30 MINUTES

NAME

INDEX NUMBER.....SIGNATURE

INSTRUCTIONS

Read the instructions carefully before answering any question.

- 1. This paper consists of 50 multiple choice questions.**
- 2. Answer all questions.**
- 3. All answers must be written on this question paper and no other papers will be provided.**

For Examiner's use only	
M/C Marks	

1. In the laboratory preparation of hydrogen, the substance that can be added to speed up the reaction is

- A. manganese(IV)oxide
- B. copper(II)sulphate
- C. platinum
- D. finely divided iron

2. Air contains about

- A. 3% carbon(IV)oxide
- B. 4% noble gases
- C. 21% oxygen
- D. 69% nitrogen

3. Chlorine dissolves in hot concentrated solution of sodium hydroxide to produce the following **except**

- A. sodium chlorate
- B. sodium hypochlorite
- C. sodium chloride
- D. water

4. The number of moles in 10.6 g of sodium carbonate is
[Na = 23, C = 12, O = 16]

- A. 0.01
- B. 0.10
- C. 0.20
- D. 1.06

5. The best method for separating salt from sea-water is

- A. filtration.
- B. decanting.
- C. centrifuging.
- D. distillation.

6. During an investigation to show the conditions under which an iron nail can rust, an experiment was set up as shown in Figure 1

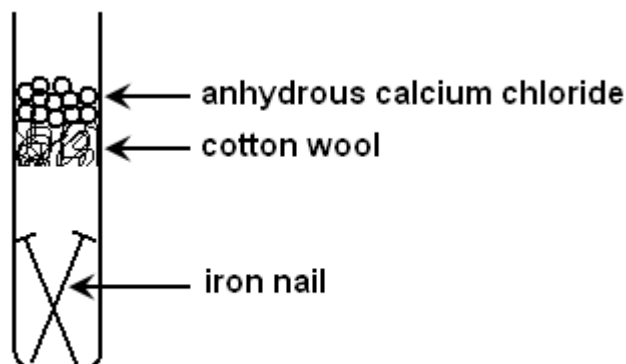

Figure 1

The condition which was being eliminated is

- A. oxygen
- B. carbon(IV)oxide
- C. moisture
- D. heat

7. A solution of ammonia in water is a base because

- A. it reacts with an acid to form a salt and water only.
- B. it reacts with an acid to form a salt and hydrogen only.
- C. it reacts with an acid to liberate carbon(IV)oxide.
- D. it reacts with an acid to produce ammonia gas.

8. A salt that dissolves in water to form a solution of pH less than seven is

- A. potassium carbonate.
- B. potassium hydrogen carbonate.
- C. ammonium sulphate.
- D. ammonium carbonate.

9. In the electrolysis of copper(II)sulphate solution using copper electrodes, the

- A. cathode loses weight.
- B. anode slowly dissolves.
- C. solution becomes colourless.
- D. anode yields hydrogen gas.

10. Which one of the following carbonates is **not** decomposed if strongly heated?

- A. calcium carbonate
- B. ammonium carbonate
- C. zinc carbonate
- D. sodium carbonate

11. A sample of nitrogen occupied 210 cm^3 at a pressure of 370 mmHg . What would the volume of the gas be if the pressure is increased to 420 mmHg at the same temperature?

- A. 185 cm^3
- B. 238 cm^3
- C. 380 cm^3
- D. 740 cm^3

12. The most important method of extracting sulphur is by the

- A. contact process.
- B. Haber process.
- C. Frasch process.
- D. electrolytic process.

13. Increasing concentration increases the rate of a reaction because the particles

- A. collide with more force.
- B. have more energy.
- C. move faster.
- D. collide more often.

14. Solution W forms a white precipitate with silver nitrate solution. The precipitate is insoluble in nitric acid. W is likely to contain

- A. SO_4^{2-}
- B. Cl^-
- C. NO_3^-
- D. CO_3^{2-}

15. A gas has the following properties

- (i) it turns blue litmus to red
- (ii) turns acidified potassium dichromate solution from orange to green

The gas is

- A. hydrogen chloride
- B. sulphur(IV)oxide
- C. carbon(IV)oxide
- D. sulphur(VI)oxide

16. A non-luminous flame is produced when the

- A. air hole of a Bunsen burner is fully open.
- B. flame is yellow.
- C. air hole of Bunsen burner is closed.
- D. flame is smoky.

17. Which one of the following is a transition metal ion?

- A. Ca^{2+}
- B. K^+
- C. Al^{3+}
- D. Fe^{2+}

18. When a gas was bubbled through a saturated calcium hydroxide solution, a white precipitate was formed. The gas is likely to be

- A. carbon(IV)oxide
- B. carbon(II)oxide
- C. sulphur(IV)oxide
- D. ammonia

19. Which one of the following compounds contains 35% nitrogen by mass?

- A. HNO_3
- B. NH_4NO_2
- C. NH_4NO_3
- D. NH_4OH

20. Graphite and diamond are both allotropes of carbon. They show

- A. different chemical and physical properties.
- B. similar chemical and physical properties.
- C. similar chemical properties by different physical properties.
- D. similar physical properties but different chemical properties.

21. Elements in the same group of the periodic table have similar physical and chemical properties. This is because

- A. they have the same number of valance electrons in each element.
- B. they have different number of valance electrons in each element.
- C. they belong to the same period.
- D. they belong to different periods.

22. The solubility of copper(II)sulphate at 30°C is 25 g per 100 g of water. The mass of copper(II)sulphate that would crystallize if a solution containing 50 g of copper(II)sulphate in 100 g of water at 60°C is cooled to 30°C is

- A. 12.5 g
- B. 25.0 g
- C. 50.0 g
- D. 75.0 g

23. Ionic compounds have high melting and boiling points because

- A. ions strongly attract each other.
- B. ions strongly repel each other.
- C. they combine by transfer of electrons.
- D. ions are arranged in a crystal lattice.

24. The alkynes are members of a homologous series of general molecular formula

- A. C_nH_{2n}
- B. C_nH_n
- C. C_nH_{2n+2}
- D. C_nH_{2n-2}

25. A current of five amperes was passed through a silver nitrate solution for one minute. The mass of silver, in grams, deposited at the cathode is [1F = 96,500C, Ag = 108]

- A. $\frac{96500 \times 60 \times 5}{108}$
- B. $\frac{5 \times 60 \times 108}{96500}$
- C. $\frac{5 \times 60}{96500 \times 60}$
- D. $\frac{5 \times 60}{96500 \times 108}$

26. Which one of the following is a compound?

- A. water
- B. sugar solution
- C. aerosol
- D. emulsion

27. During the Haber process, the equilibrium reaction below is considered:



Which one of the following conditions would give a reasonable yield of ammonia?

- A. Addition of a catalyst.
- B. Increasing the temperature of the system.
- C. Doubling the volume of the system.
- D. Increasing the pressure of the system.

28. Permanent hard water can be softened by

- A. adding sodium carbonate.
- B. boiling the water.
- C. adding calcium hydroxide.
- D. adding aqueous ammonia.

29. The heat of hydration and lattice energy of sodium chloride are -771 kJ and

+776 kJ respectively. The heat of solution of sodium chloride is

- A. -5 kJ mol^{-1}
- B. $+1547 \text{ kJ mol}^{-1}$
- C. $-1547 \text{ kJ mol}^{-1}$
- D. $+5 \text{ kJ mol}^{-1}$

30. The standard electrode potentials for copper, hydrogen, silver and zinc half-cells are given in Table 1.

oxidizing agent	reducing agent	standard electrode potential
$\text{Cu}^{2+}(\text{aq}) + \text{e}^{-} \longrightarrow$	$\text{Cu}(\text{s})$	+0.34
$\text{H}^{+}(\text{aq}) + \text{e}^{-} \longrightarrow$	$\frac{1}{2}\text{H}_2(\text{g})$	0.00
$\text{Ag}^{+}(\text{aq}) + \text{e}^{-} \longrightarrow$	$\text{Ag}(\text{s})$	+0.80
$\text{Zn}^{2+}(\text{aq}) + 2\text{e}^{-} \longrightarrow$	$\text{Zn}(\text{s})$	-0.76

Table 1

The least powerful oxidizing agent is

- A. $\text{H}^{+}(\text{aq})$
- B. $\text{Zn}^{2+}(\text{aq})$
- C. $\text{Ag}^{+}(\text{aq})$
- D. $\text{Cu}^{2+}(\text{aq})$

31. Which one of the following gaseous hydrocarbons decolourizes bromine water?

- A. CH_4
- B. C_2H_4
- C. C_2H_6
- D. C_3H_8

32. An alloy of two metals X and Y is completely dissolved in dilute nitric acid. The blue resultant solution formed was divided into two halves and tested as follows:

- (i) on addition of excess ammonia solution, a deep blue coloration occurred.
- (ii) on addition of potassium iodide solution, a thick yellow precipitate formed.

The alloy most likely contained

- A. copper and zinc
- B. lead and zinc
- C. copper and lead
- D. copper and aluminium

33. The process by which the diesel fraction in petroleum refining is converted to

petrol is called

- A. cracking.
- B. reformation.
- C. cylisation.
- D. aromatisation.

34. To a solution of the salt containing calcium ions was added sodium carbonate solution followed by dilute nitric acid. Which one of the following best describes what was observed?

- A. A white precipitate was formed.
- B. A white precipitate was formed and later dissolved.
- C. A white precipitate was formed but dissolved later with effervescence.
- D. Effervescence occurred and a colourless gas was evolved.

35. Which one of the following oxides will dissolve in dilute nitric acid and dilute sodium hydroxide solution?

- A. ZnO
- B. MgO
- C. SO₂
- D. CuO

36. Detergents are a pollution danger because of

- A. the small quantity of foam they produce.
- B. no quantities of foam they produce.
- C. the large quantities of foam they produce.
- D. their high solubility in water.

37. The emissions from radioactive nuclides include:

- A. beta, cathode and alpha particles.
- B. infrared, alpha and gamma particles.
- C. neutron, beta and alpha particles.
- D. beta, photon and gamma particles.

38. The oxidation number of manganese in MnO₄⁻ is

- A. +4
- B. -4
- C. +6
- D. +7

39. According to the kinetic theory of matter, a dive into water demonstrates that

- A. the forces of attraction between particles of a liquid are very weak and are easily broken.
- B. the forces of attraction between particles of a liquid are very strong and are not easily broken.
- C. no forces of attraction exist between particles of a liquid.
- D. the particles of a liquid attract each other and vibrate.

40. The following substances are hygroscopic.:

- (i) copper(II)oxide
- (ii) calcium chloride
- (iii) calcium oxide
- (iv) sodium hydroxide

Which of them is/are deliquescent?

- A. (i), (ii) and (iii) only.
- B. (i) and (iii) only
- C. (ii) and (iv) only
- D. (iv) only

41. The term reduction means

- A. removal of hydrogen from a substance.
- B. removal of oxygen from a substance.
- C. removal of neutrons from a substance.
- D. removal of electrons from a substance.

42. What is the name of the organic compound represented by the formula shown below?

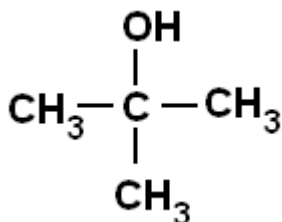

- A. propan-2-ol
- B. 2-methyl propan-2-ol
- C. 3-methyl propan-2-ol
- D. 2, 2-methyl propaol

43. Dissolved solutes in a pure liquid bring about

- A. the elevation of the boiling point.
- B. the depression of the boiling point.
- C. the elevation of the freezing point.
- D. rapid evaporation

44. Which one of the following is **not** a factor to be considered in selecting a method of collecting a gas sample in the laboratory?

- A. density
- B. toxicity
- C. solubility in water
- D. pressure

45. Which one of the following bases is very soluble in water?

- A. $\text{Ba}(\text{OH})_2$
- B. $\text{Zn}(\text{OH})_2$
- C. $\text{Ca}(\text{OH})_2$
- D. KOH

46. The molar heat of fusion is the

- A. amount of heat required to convert 1 mole of a solid into liquid at the same temperature.
- B. amount of heat required to convert 1 g of a solid into liquid at the same temperature.
- C. amount of heat required to convert 1 mole of a liquid into vapour at the same temperature.
- D. amount of heat required to convert 1 g of liquid into vapour at the same temperature.

47. Which one of the following is a basic oxide?

- A. CO_2
- B. CaO
- C. H_2O
- D. SO_2

48. Isotopes of an element X-16 and X-18 occur naturally in the ratio 9:1 respectively. The relative atomic mass of X is

- A. 14.4
- B. 16.2
- C. 18.2
- D. 34.0

49. The energy level diagram in Figure 2 (next page) shows enthalpy change during

formation of nitrogen(II)oxide

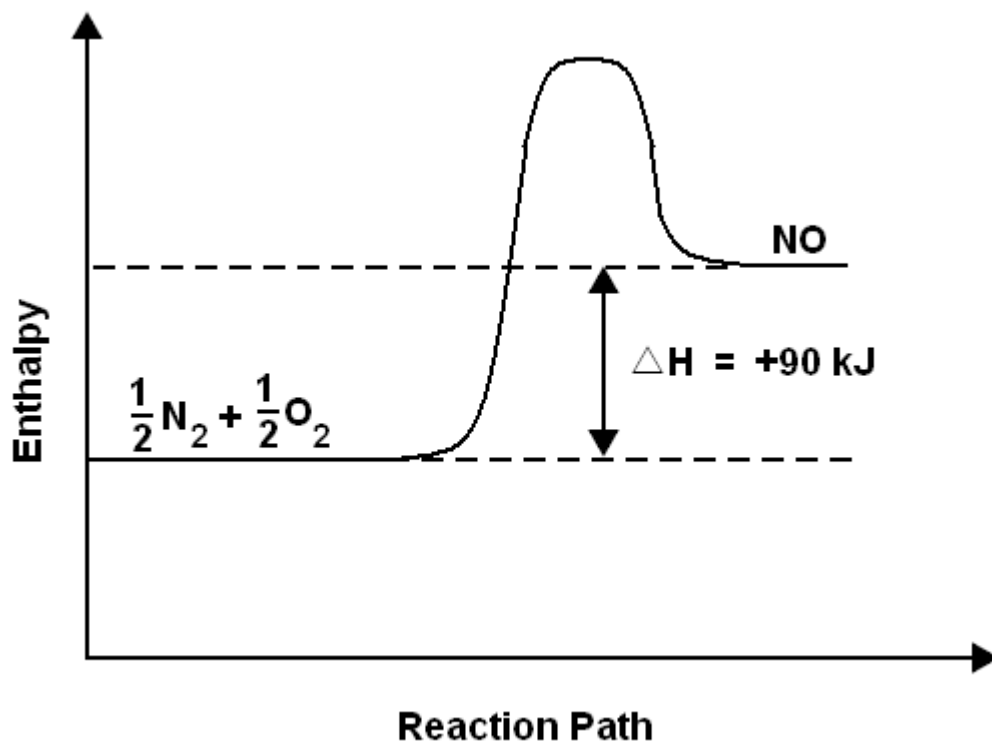

Figure 2

The energy profile in Figure 2 shows that

- A. heat content of reactants is higher than that of product.
- B. heat has been liberated to the surrounding by the reactants.
- C. heat content of both reactants and products is constant.
- D. heat has been absorbed from the surrounding by the reactants.

50. Which of the following is a dibasic acid?

- A. sulphuric acid
- B. nitric acid
- C. phosphoric acid
- D. hydrochloric acid

END



Republic of South Sudan
Ministry of General Education & Instruction
Secretariat of Examinations

042/2
Chemistry
Paper 2
2 hours

SOUTH SUDAN CERTIFICATE OF SECONDARY EDUCATION EXAMINATIONS
NOV/DEC. 2012

CHEMISTRY
PAPER TWO

TIME: 2 hours

NAME.....

INDEX NUMBER.....SIGNATURE

INSTRUCTIONS

Read the instructions carefully before answering any question.

1. This paper consists of two sections: A and B. Section A has 10 structured questions and Section B has 5 semi-structured questions.
2. A candidate is required to answer ALL questions in Section A and any 2 questions in Section B.
3. Answers to section A must be written in the spaces provided and answers to section B must be written on the answer booklet provided.

For Examiner's Use only											
Section A	1	2	3	4	5	6	7	8	9	10	Total A
Section B	11	12	13	14	15						Total B
Total											

Section A (50 marks)

Answer ALL the questions in this section.

1. (a) Name one process in each case by which the concentration of carbon(IV)oxide in the atmosphere is

(i) increased(1 mark)

(ii) decreased(1 mark)

(b) (i) State what would be observed if burning magnesium ribbon was lowered into a jar of carbon(IV)oxide.

.....
.....
.....

.....(1½ marks)

(ii) Write the equation for the reaction that takes place in b(i).

.....(1½ marks)

2. The number of protons and neutrons in atoms K, A, B and S are shown in Table 1.

Atom	Protons	Neutrons
K	1	0
A	7	7
B	13	15
S	7	9

Table 1

(a) (i) Which atoms are isotopes of an element?

.....(1 mark)

(ii) Write the electronic configuration of atom B.

.....(1 mark)

(b) What type of bonding exists in the compound formed when A reacts with K?

.....
(1 mark)

(c) The electronic configurations of the ions of Q and R are given as:

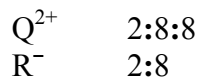

Find the group and period to which each element belongs.

Q:(1 mark)

R:(1 mark)

3. (a) Define the following terms:

(i) diffusion
.....(1 mark)

(ii) effusion
.....(1 mark)

(b) A certain gas takes two times as long to effuse as it takes helium gas under the same conditions. Find the molecular mass of the gas. [He = 4]

.....
.....
.....
.....
.....
.....
.....
.....(3 marks)

4. (a) (i) State two differences between monoclinic sulphur and rhombic sulphur.

.....
.....
.....
.....
.....(2 marks)

(ii) Apart from sulphur and carbon, name one other element that shows allotropy.

.....(1 mark)

(b) Sulphur reacts with sulphuric (VI) acid only on certain condition.

(i) State the condition for the reaction to take place.

.....
.....(½ mark)

(ii) Write the equation for the reaction.

.....
.....(1½ marks)

5. (a) State Hess's Law of constant heat summation.

.....
.....
.....(1 mark)

(b) Given that

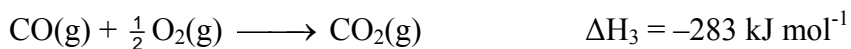

(i) Draw an energy cycle for the heat of formation of carbon(IV)oxide.

.....
.....
.....
.....
.....(2 marks)

(ii) Calculate the enthalpy of formation of carbon(II)oxide, that is, the value of ΔH_f^\ominus .

.....

.....

.....

.....

.....

.....

.....(2 marks)

6. An experiment was set as shown in Figure 1 below to study some chemistry of hydrogen gas.

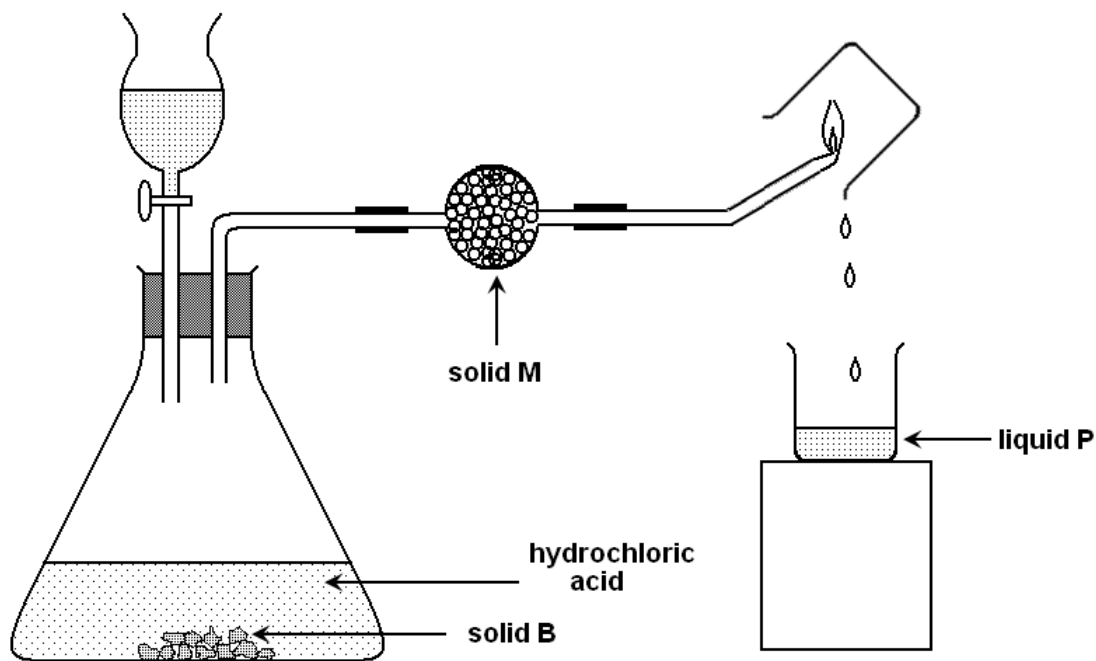

Figure 1

(a) (i) Identify solids B and M

B

M(1 mark)

(ii) Write an equation for the reaction between hydrochloric acid and solid B.

.....

.....(1½ marks)

(b) What is the purpose of M?

.....
.....

.....(1 mark)

(c) (i) Identify liquid P.

.....(½ mark)

(ii) How can you test for the identity of liquid P?

.....
.....

.....(1 mark)

7. (a) (i) State two properties which show that air is a mixture.

.....
.....

.....(2 marks)

(ii) Name two gases, other than oxygen, that are constituents of air.

.....
.....

(b) Oxygen can be prepared in the laboratory using potassium chlorate and a substance X.

(i) Name X

.....(½ mark)

(ii) Write the equation leading to the formation of oxygen.

.....
.....

.....(1½ marks)

8. (a) The substance Y reacts with solid sodium chloride to produce hydrogen chloride.

(i) Identify Y

.....(½ mark)

(ii) State the conditions for the reaction.

.....
.....(1 mark)

(iii) Write the equation for the reaction.

.....(1½ marks)

(b) Hydrogen chloride was dried and passed over heated iron filings.

(i) State what would be observed.

.....
.....(½ mark)

(ii) Write the equation for the reaction that took place.

.....(1½ marks)

9. The graph in Figure 2 shows the effect of temperature on the rate of reaction between marble chips of the same mass and excess 2M hydrochloric acid.

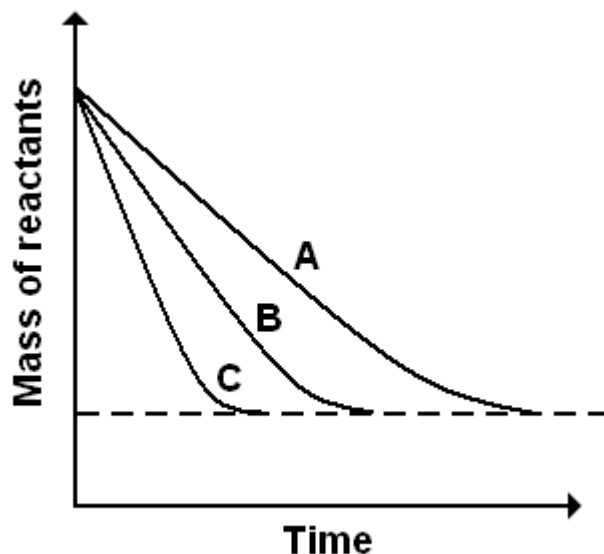

Figure 2

- (a) If curve B is for the reaction at 40°C, which curve shows the reaction taking place at
- (i) 20°C
- (ii) 60°C (1 mark)

(b) Explain why the curves eventually end at the same level.

.....

.....

.....

.....

.....(1½ marks)

(c) Write the equation of reaction between marble chips (calcium carbonate) and hydrochloric acid.

.....

.....(1½ marks)

(d) State one other method that can be used to measure the rate of reaction between marble chips and hydrochloric acid.

.....(1 mark)

10. The diagram in Figure 3 shows how states of matter can change under different conditions.

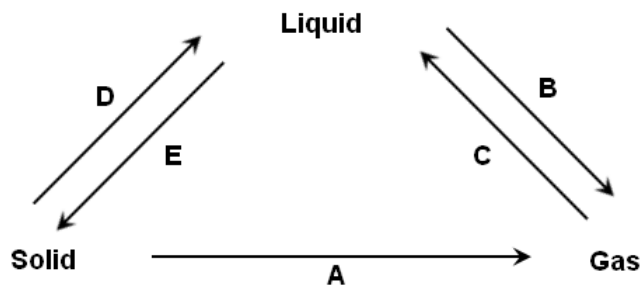

Figure 3

(a) Name the change of state of matter represented by:

(i) A

(ii) B

(iii) C

(iv) D

(v) E

(2½ marks)

(b) Name two substances that can undergo the change of state represented by A.

.....

.....(2 marks)

(c) State one condition that can bring about the change of state represented by C.

.....

.....(½ mark)

Section B: (20 marks)

Answer only TWO questions.

11. (a) Crude ethanol is manufactured by the process known as fermentation.
- (i) Explain what is meant by the term fermentation. (1 mark)
 - (ii) Write equation for the reaction that takes place. (1 mark)
- (b) Write equation to show how ethanol can be converted to ethene and indicate the conditions for the reaction. (2 marks)
- (c) An organic compound A contains 52.2% carbon, 13.0% hydrogen and 32.8% oxygen. [H = 1, C = 12, O = 16]
- (i) Calculate the empirical formula of A. (3 marks)
 - (ii) If the molecular mass of the compound is 46, what is its molecular formula? (2 marks)
- (d) Write the structural formula of A. (1 mark)
12. (a) Define the terms
- (i) a normal salt (1 mark)
 - (ii) an acid salt (1 mark)
- (b) Describe briefly how copper(II)sulphate crystals can be prepared from copper(II)oxide.
(5 marks)
- (c) Copper(II)carbonate reacts with dilute hydrochloric acid according to the equation
- $$\text{CuCO}_3(\text{s}) + 2 \text{HCl}(\text{aq}) \longrightarrow \text{CuCl}_2(\text{aq}) + \text{H}_2\text{O}(\text{l}) + \text{CO}_2(\text{g})$$
- What volume of carbon dioxide would be evolved at s.t.p. when 6.2 g of copper(II)carbonate is reacted with excess dilute hydrochloric acid?
[Cu = 64, C = 12, O = 16, molar gas volume at s.t.p. = 22.4 litres] (3 marks)
13. (a) Name one important ore from which iron is extracted and write its chemical formula. (2 marks)
- (b) Outline briefly the chemical processes involved in extracting a pure sample of iron from its ore you have named in (a) above. (7 marks)
- (c) State one use of iron. (1 mark)

14. Nitric acid is manufactured by catalytic oxidation of ammonia.

(a) Name

(i) two raw materials, other than ammonia, that are used in the manufacture of nitric acid. (1 mark)

(ii) the catalyst used. (1 mark)

(b) Write equation for the reaction between nitric acid and ammonia. (1 mark)

(c) State one use of the product in (b). (1 mark)

(d) Explain the following observations and write equation(s) where necessary for the reaction(s) which take place.

(i) When a few drops of concentrated nitric acid were added to iron(II)sulphate solution and warmed gently, the solution turned from pale green to rusty brown. (3½ marks)

(ii) When dilute nitric acid is added to zinc metal, the metal dissolves but no hydrogen gas is liberated. (2½ marks)

15. (a) Explain what is meant by electroplating. (2 marks)

(b) In the space below, draw a labelled diagram of the apparatus that can be used to copper plate an object (metal) in the laboratory. (3 marks)

(c) Molten lead(II)bromide was electrolysed between carbon electrodes. Write an equation for the reaction that took place at each electrode.

(i) anode (1 mark)

(ii) cathode (1 mark)

(d) Calculate the mass of the product formed at the cathode when a current of 2 amperes is passed for one hour and thirty minutes.
[Pb = 207, Br = 80, 1 Faraday = 96500 Coulombs] (3 marks)

END



**GOVERNMENT OF SOUTHERN SUDAN
MINISTRY OF EDUCATION
EXAMINATIONS SECRETARIAT**



**SOUTHERN SUDAN CERTIFICATE OF SECONDARY EDUCATION (S.S.C.S.E)
EXAMINATIONS**

Nov./Dec. 2010

043/1 BIOLOGY

2½ HOURS

NAME (CAPITAL LETTERS):

INDEX NUMBER **SIGNATURE**.....

INSTRUCTIONS

Read the instructions carefully before answering any questions.

1. This paper consist of three Sections **A**, **B** and **C**.
2. Attempt all questions in Section **A** and **B** and any **two** questions in Section **C**.
3. Write your answers to questions in Section A and B in the spaces provided on the question paper; and answers to Section C questions in the answer booklet.
4. The question paper and the answer booklet used by a candidate must be tied together and handed to the supervisor.

FOR EXAMINER'S USE ONLY		
SECTION		
A	20	
B	40	
C	40	
TOTAL	100	

SECTION A: (20 MARKS)

Attempt all questions in this Section.

Write the letter corresponding to your chosen correct answer to each question in the box at the right side of the paper.

Q1: Which group of the following organisms belong to the same genus?

- A. *Leo canaries, Bos canaries, Leo canis.*
- B. *Leo canaries, Leo canis, Leo fedinards.*
- C. *Bos indicus, Leo indicus, Solanum indicus.*
- D. *Solanum nigrum, Leo nigrum, Solanum incanum.*

Q2: The process of breaking down food to release energy in the Mitochondria is termed as _____.

- A. Tissue respiration.
- B. Excretion.
- C. Transpiration.
- D. Irritability.

Q3: Which of the following structures are found in a typical animal cell?

- A. Cell wall, cell membrane and chloroplast.
- B. Cell wall, Nucleus and chloroplast.
- C. Cell membrane and nucleus.
- D. Cell membrane and chloroplast.

Q4: Which one of the following is not true about mutation?

- A. Mutation may affect single genes or chromosomes.
- B. All mutations produce harmful effects.
- C. A mutant gene can be passed on to the offspring during fertilization.
- D. Mutation are the raw materials for evolution.

Q5: Starch is converted in the mouth into_____.

- A. Maltose.
- B. Amino Acid.
- C. Glucose.
- D. Peptide.

Q6: Which one of the following hormones is responsible for ovulation in human beings?

- A. Follicle stimulating hormone.
- B. Luteinising hormone.
- C. Progesterone.
- D. Oestrogen.

Q7: Nerves, spinal cord and brain make up:

- A. a tissue.
- B. a system.
- C. an organ.
- D. an organism.

Q8: Which one of these processes helps to lower mammalian body temperature?

- A. Vasodilatation.
- B. Vasoconstriction.
- C. Shivering.
- D. Raising of hairs on skin.

Q9: The diagram below is a cross section of a stem of a dicotyledonous plant. What is the function of the part labeled C?

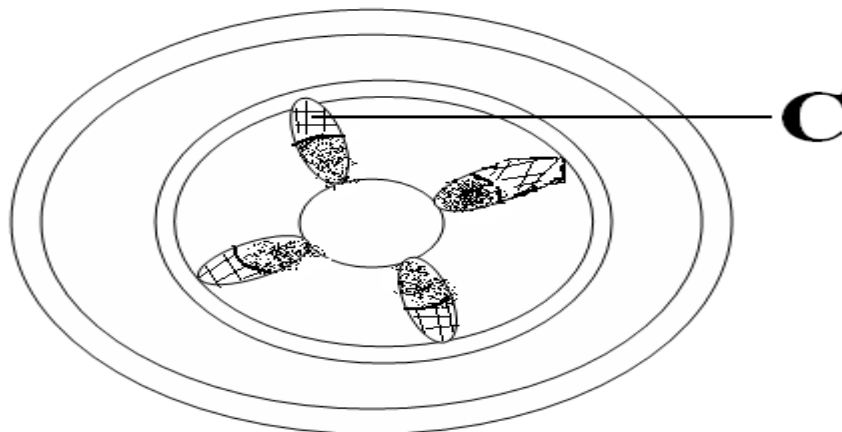

- A. Conduct water and mineral salts.
- B. Conduct food and other materials.
- C. Conduct food, water and mineral salts.

D. Conduct waste materials.

Q10: What is the relationship between a groundnut plant and Nitrogen fixing bacteria in its root nodules?

- A. Parasitism.
- B. Saprophytism.
- C. Naturalism.
- D. Symbiosis.

Q11: Which one of the following is a characteristic of insects only?

- A. Exoskeleton.
- B. Jointed legs.
- C. Two pairs of wings.
- D. Three body divisions.

Q12: The graph below shows the rate of growth of a bean seedling against temperature.

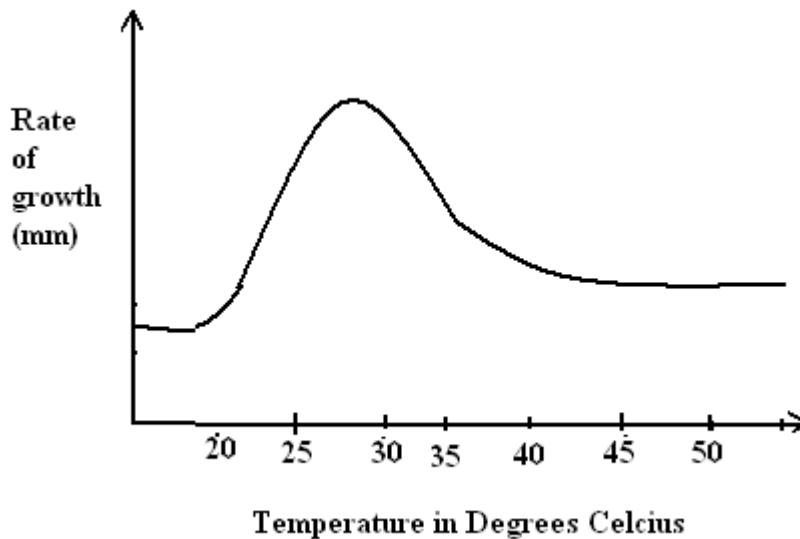

From the graph, which temperature range should the farmer choose for his seedling?

- A. 25 to 45.
- B. 25 to 30.
- C. 20 to 40.
- D. 20 to 35.

Q13: The primary minerals found in bone are _____.

- A. Iron and calcium.
- B. Calcium and phosphate.
- C. Iron and phosphate.
- D. Calcium and potassium.

14: Select the correct order of level of organization from the lowest to the highest.

- A. Tissue – Cell – Organ – System - Organ.
- B. Cell – organ – Tissue – System - Organization.
- C. Cell -Tissue -Organs –System -Organs.
- D. System – Cell – Tissue – Organ – Organism.

Q15: What is likely to happen to a population that is reduced to small size?

- A. High mutation rate.
- B. high rate of gene flow.
- C. loss of genetic variation.
- D. stabilization selection.

Q16: The mechanical analysis of soil is based on:

- A. Soil colour.
- B. Soil particles.
- C. Soil profile.
- D. Soil constituent.

Q17: Gaseous exchange in simple plants takes place by _____.

- A. diffusion across xylem of the leaves
- B. diffusion across xylem of the vessel.
- C. diffusion across chloroplast.
- D. diffusion across cell membrane.

Q18: The mode of feeding in mucor is known as:

- A. Holozoic nutrition.
- B. Filter feeding.
- C. Parasitic nutrition.
- D. Saprophytic nutrition.

Q19: The hormone that promotes growth of plant shoot is _____.

- A. Indole acetic acid.
- B. Auxin.
- C. Lactic acid.
- D. Lanolin.

Q20: Identical twins are produced when:

- A. Each ovary releases two eggs and each egg is fertilized.
- B. One ovary releases two eggs and each is fertilized.
- C. An egg divided into two parts which are fertilized.
- D. One sperm fertilize one egg and the zygote formed divided into two.

SECTION B:(40 marks)

Answer all questions from this section in the spaces provided.

Q21: Define:

(a) (i) Seed viability **1 mark**

(ii) Write down two factors affecting seed viability **2 marks**

(b) Table below shows length of internodes and the time:

Time/days	Lengths/mm
0	0
4	5
8	10
12	20
16	25

(i) Plot a graph of length of internodes against time. **2 marks**

(ii) From the graph, obtain the average growth rate in mm/day. **2 mark**

Q22: Outline any four (4) differences between

4 marks

(a) Arteries and Veins.

Arteries	Vein
1-	1-
2-	2-
3-	3-
4-	4-

(b) What are the functions of the following vessels in the mammalian heart?

(i) Pulmonary Artery: **1 mark**

(ii) Pulmonary Vein: **1 mark**

Q23: Define:

2 marks

(a) Symbiosis

(b) Explain the symbiotic relationship between Rhizobium in the root nodules and Leguminous plants.

2 marks

(c) How does man benefit from the relationship in (b) above:

1 mark

(d) Distinguish between symbiosis and commensalism:

2 marks

Q24: A group of students undertook to study the characteristics of soil by digging vertically through soil samples. The upper layers of the soil samples in each case were darker than the lower layers.

- (a) Explain why the upper layers of the soil samples were darker than the lower layers. **4 marks**

- (b) Draw a labeled diagram to show the appearance of a vertical section through the soil sample. **2 marks**

Q25: The diagram below shows a longitudinal section through the female reproductive system of a human being

5 marks

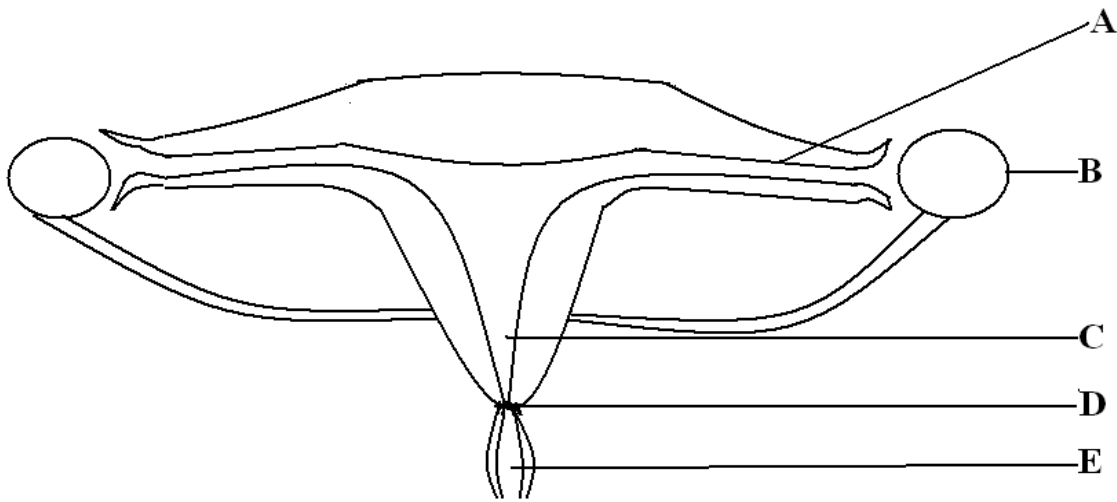

- (a) Name the parts labeled:

A	_____	D	_____
B	_____	E	_____
C	_____		

(b) State the function of the part labeled B.

1 mark

Q26: The diagram below represent a neurone

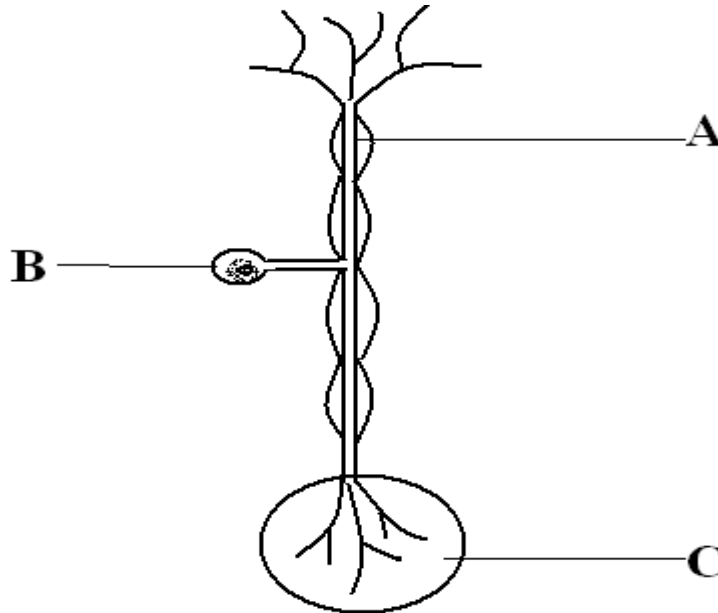

(a) Name the parts labelled A, B, and C in the diagram

3 marks

A _____ B _____ C _____

(b) By mean of an arrow, show the direction of the impulse along the neurone.

1 mark

(c) Give the functional differences between endocrine and neurons system 4 marks

Endocrine	Nervous system
1- _____ _____	1- _____ _____
2- _____ _____	2- _____ _____
3- _____ _____	3- _____ _____
4- _____ _____	4- _____ _____

SECTION C: (40 marks)

Answer only two questions including question 27 from this section in the answer booklet.

- Q27: (a) Define the following terms: **4 marks**
- (i) Sex-linked gene.
 - (ii) Recessive trait.
 - (iii) Dominant trait.
 - (iv) Albinism.
- (b) State the difference between the genotype and phenotype of an individual. **4 marks**
- (i) Given haemophilia is a sex-linked disorder of blood, and if a haemophilic female marries a normal man, using a Punnett square, determine the possible genotype of their children. **4 marks**
 - (ii) Determine possible phenotypes of children born by sons from the cross in b (i) if they marry females who are carriers. **4 marks**
- (c) Explain the following **4 marks**
- (i) Complete dominance.
 - (ii) Incomplete dominance.
 - (iii) Alleles.
 - (iv) Gene locus
- Q28: (a) Describe any four (4) general characteristics of Kingdom Animalia **4 marks**
- (b) Citing specific examples, describe the principle of binomial system of naming organisms. **10 marks**
- (c) Explain any three reasons why it is important to classify organisms. **6 marks**
- Q29: (a) Draw and label a mammalian nephron. **8 marks**
- (b) Describe the process of filtration and reabsorption in the nephron. **8 marks**
- (c) With examples, explain homeostasis. **4 marks**

- Q30: (a) (i) Outline the theory of continental drift. **2 marks**
- (ii) Describe how continental drift has contributed do the process of evolution. **8 marks**
- (b) (i) Explain the theory of natural selection. **8 marks**
- (ii) Citing one specific example, explain what is meant by divergent evolution. **2 marks**

END



Republic of South Sudan
Ministry of General Education & Instruction
Secretariat of Examinations

SOUTH SUDAN CERTIFICATE OF SECONDARY EDUCATION (S.S.C. S.E)
EXAMINATIONS

Nov. /Dec. 2011

043/1 BIOLOGY

Time: 2¹/₂ Hours

NAME (CAPITAL LETTERS).....

INDEX NUMBER.....SIGNATURE.....

INSTRUCTIONS:

Read the instructions carefully before answering any questions.

1. This paper consists of three sections A, B and C.
2. Answer all questions in sections A and B and two questions in sections C.
3. Write your answers to sections A and B in the spaces provided on the question paper and section C in separate answer booklet.
4. All biological drawings must be in pencil.
5. The question paper and the answer booklet used by a candidate must be tied together and handed to the supervisor.

FOR EXAMINER'S USE ONLY		
SECTION	MARK	SCORE
A	20	
B	40	
C	40	
TOTAL	100	

© Ministry of General Education & Instruction, SSCSE, 2011.

TURN OVER

SECTION A (20 MARKS)

Attempt all questions in this section. Write the letter corresponding to your chosen correct answer to each question in the box provided at the right side of the paper.

1. The ability of a living organism to respond to a given stimulus is termed as-----

- A. Movement
- B. Irritability
- C. Growth
- D. Feeding

2. Which of the statements below differentiates aerobic respiration and anaerobic respiration?

- A. Aerobic respiration occurs only in the presence of oxygen while anaerobic respiration can occur temporarily in the absence of oxygen.
- B. Anaerobic respiration only occurs in the presence of oxygen whereas aerobic respiration can occur temporarily in the absence of oxygen.
- C. Anaerobic respiration yields more energy than aerobic respiration.
- D. Anaerobic respiration produces lactic acid in animals whereas anaerobic respiration produces glucose in animals.

3. Which of the following is the correct sequence in the level of organization of an organism?

- A. Cells, organs, tissue, system.
- B. Tissue, organs, cells, system.
- C. Cells, tissues, organs, system.
- D. Organs, tissues, cells, system.

4. If the parental genotype of a given species is XX and XY, what is the ratio of male to female offsprings?

- A. 2:1.
- B. 3:2:1
- C. 1:1.
- D. 3:1.

5. Figure I shows an experiment to investigate the gas given off during photosynthesis.

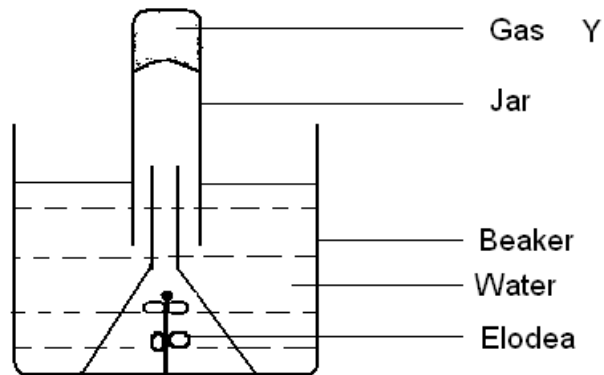

Figure 1

The gas Y collected in the jar is-----

- A. Oxygen
- B. Carbondioxide
- C. Nitrogen
- D. Chlorine gas

6. Which one of the following hormones is responsible for ovulation in human beings?

- A. Follicle stimulating hormone
- B. Luteinising hormone
- C. Progesterone
- D. Oestrogen

7. Figure 2 shows the structure of a motor neurone.

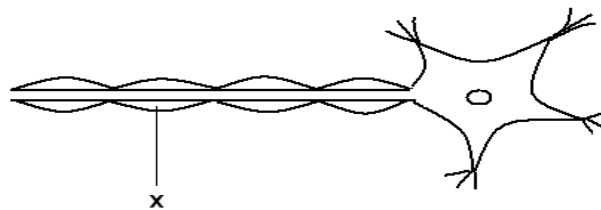

Figure 2

Name the part marked X.

- A. Nucleus
- B. Schwann cell
- C. Axon
- D. Dendrites

8. The list below shows excretory products of plants:

- i- Tannins ii- Rubber iii- Caffeine
iv- Quinine v- Bhang.

Which of the above products are used as drugs by man?

- A. i, ii, iii and v
B. i, ii and iii
C. ii, and v
D. iii, iv and v

9. In the circulatory system, which of the following vessels transports blood rich in nutrients?

- A. Pulmonary artery
B. Renal vein
C. Hepatic portal vein
D. Pulmonary vein

10. Within an ecosystem the total number of secondary consumers must be-----

- A. less than the total number of herbivores
B. greater than the total number of herbivores
C. equal to the number of herbivores
D. equal to the number of producers

11. Which one of the following sequences shows the correct life cycle of a butterfly?

- A. Pupa, eggs, larva, adult
B. Larva, eggs, pupa, adult
C. Eggs, larva, pupa, adult
D. Eggs, pupa, larva, adult

12. Which of the following bacteria has a spherical shape?

- A. Coccus
B. Spirillum
C. Bacillus
D. Vibrio cholerae

13. Figure 3 show the diagram of the internal structure of an arm.

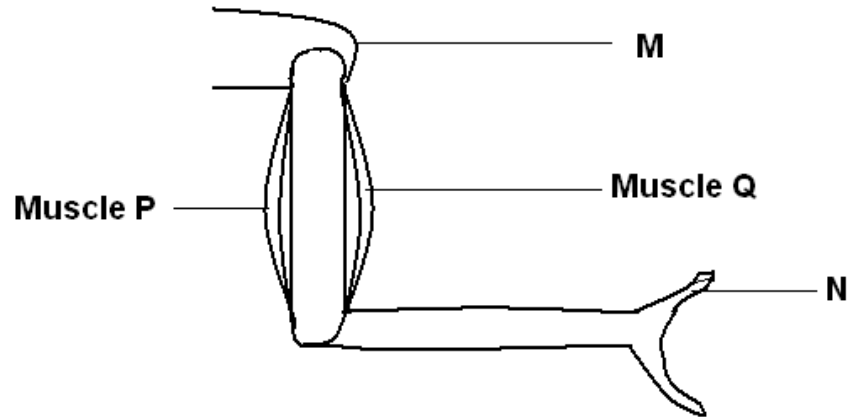

Figure 3

The movement of muscle P and Q when the fingers at N touch M is-----

- A. Muscle P relaxes and Q contracts
- B. Muscle Q relaxes and P contracts
- C. Muscle P and Q both relax
- D. Muscle P and Q both contract

14. The best way to obtain a turgid cell during a biological practical is by -----

- A. Putting a cell in a disc which contains iodine
- B. Putting a cell in a disc that contains water
- C. Putting a cell in a disc which contains sugar
- D. Putting a cell in a dry container

15. Fossil record in evolution refers to:

- A. Arrangement of fossils according to ages
- B. Arranging the fossils according to geographical distribution
- C. Arranging the fossils according to cytology
- D. Comparative embryology

16. The following results were obtained by a student in a study of a soil sample:

- i) The mass of soil and Petri dish before heating = 32g
- ii) The mass of soil and Petri dish after heating = 28g

What causes the reduction in the mass of the soil?

- A. Water, gravels and microbes were destroyed
- B. Water was expelled
- C. Heat has reduced soil density
- D. Some soil particles were expelled

17. Gaseous exchange in simple plants is through-----

- A. diffusion across stomata of the leaves
- B. diffusion across xylem vessels
- C. diffusion across chloroplast
- D. diffusion across cell membrane

18. Products of photosynthesis are-----

- A. glucose and carbondioxide
- B. oxygen and starch
- C. oxygen and glucose
- D. carbondioxide and water

19. Graph I below shows the record of an embryo height during its first 30 weeks of growth.

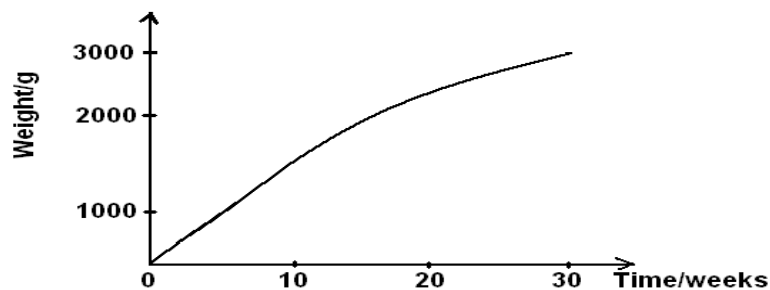

Graph 1

What is the average increase in weight per week during this period?

- A. 1000g per week.
- B. 100g per week.
- C. 200g per week.
- D. 30g per week.

20. Both mucor and rhizopus reproduce by means of:

- A. Seed
- B. Binary fission
- C. Spores
- D. Budding

SECTION B

Answer all the questions in the spaces provided.

21. An experiment was carried out on seed germination using two flasks A and B for four days.

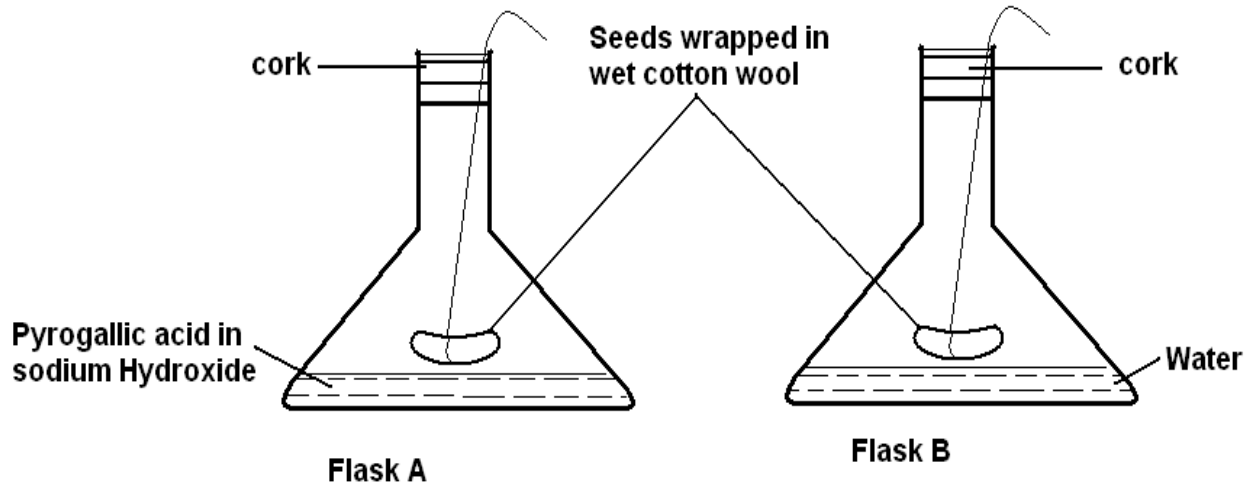

Figure 4

- a) State what was being investigated in the experiment. (1 Mark)

.....
.....

- b) Explain what happens in flasks A and B.

A.....
.....
B.....
.....(3 Marks)

- c) i) Describe a chemical test for the gas produced in flask B.

.....
.....(1 Mark)

- ii) Outline two other factors that affect germination of a seed.

.....
.....(2 Marks)

22. a) Differentiate between the following:

- i) Open circulatory system and closed circulatory system.

.....
.....(1 mark)

ii) capillaries and veins

.....
.....
..... (1 Mark)

b) Briefly explain the process of blood clotting in man.

.....
.....
.....
.....
.....
..... (3 Marks)

c) Name any two diseases associated with human circulatory system (1 Mark)
i).....
ii).....

23. a) Citing one example in each case, define the following terms:

i) Habitat.....
.....
ii) Ecological niche
.....
iii) Population.....
.....
iv) Biomass.....
..... (4 Marks)

b) How can water pollution be controlled by a community?

.....
.....
.....
..... (3 Marks)

24. Figure 5 shows the results recorded from a soil sample by the process of sedimentation.

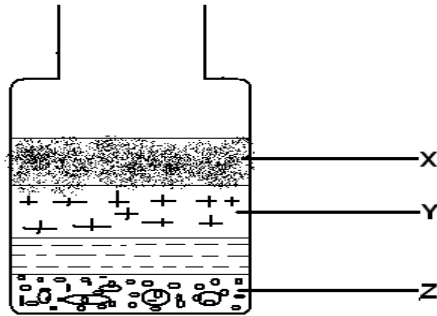

Figure 5

a) i) Name the fraction marked: (1½ Marks)

X

Y

Z

i) Explain why the upper layer of soil is always darker than the lower ones.

.....

(1½ Marks)

b) i) Give two differences between sandy soil and clay soil.

.....

(2 Marks)

ii) What is leaching as applied to soil?

.....

(1Mark)

25. a) Define internal fertilization.

.....

(1 Mark)

b) Figure 6 below is of a sperm cell.

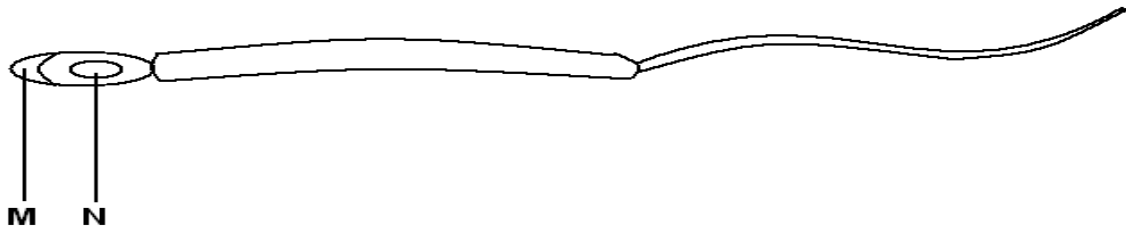

How do parts do marked M and N enhance the process of reproduction?

M.....
.....
N.....
.....(3 Marks)

C i) outlines any two differences between mitosis and meiosis.
.....
.....
.....(2 Marks)

ii) What is the significance of meiosis in reproduction?
.....
.....
.....(2 Marks)

26. a) What are the roles played by the following hormones in the mammalian body:

i) Thyroxine. (2 Marks)
.....
.....

ii) Adrenaline. (2 Marks)
.....
.....

b) i) State one functional difference between the brain and the spinal cord.
..... (1 Mark)

ii) Mention two types of nerves that constitute the peripheral nervous system.
..... (2 Marks)

SECTION C

Answer question number 27 and one other.

27. a) Explain the following terms in genetics.
- i) Complete dominance (2 Marks)
 - ii) Sex-linkage (2 Marks)
- b) i) State Mendel's laws of heredity. (2 Marks)
- ii) A Colour blind woman marries a normal man. Using appropriate symbols, determine the phenotypes and genotypes of their offsprings. (10 Marks)
- c) Explain two ways by which the study of mutations can be helpful to man. (4 Marks)
28. a) Outline the principles of binomial system of naming organisms. (4 Marks)
- b) Describe how gas exchange occurs in the tracheal system of insects. (6 Marks)
- c) i) Outline any four characteristics of class Aves. (4 Marks)
- ii) How are birds adapted for flight? (6 Marks)
29. a) Outline the importance of water to animals. (5 Marks)
- b) Describe how water balance is maintained in the mammalian body. (10 Marks)
- c) Explain the functions of the mammalian skin. (5 Marks)
30. a) In the study of evolution, explain what is meant by:
- i) Variation. (2 Marks)
 - ii) A vestigial organ (2 Marks)
 - iii) A fossil (2 Marks)
- b) Citing specific examples, explain Larmark's theory of evolution. (8 Marks)
- c) How do some bacteria develop resistance to antibiotics? (6 Marks)

THE END



Republic of South Sudan
Ministry of General Education & Instruction
Secretariat of Examinations

043/1
BIOLOGY
PAPER ONE
Time: 2¹/₂ Hours

SOUTH SUDAN CERTIFICATE OF SECONDARY EDUCATION (S.S.C.S.E)
EXAMINATIONS

NOV. /DEC. 2012

NAME

INDEX NUMBER.....SIGNATURE.....

INSTRUCTIONS:

Read the instructions carefully before answering any questions.

1. This paper consists of three sections A, B and C.
2. Answer all questions in sections A and B and two questions in section C.
3. Write your answers to sections A and B in the spaces provided on the question paper and section C in a separate answer booklet.
4. The question paper and the answer booklet used by a candidate must be tied together and handed to the supervisor.

FOR EXAMINER'S USE ONLY		
SECTION	MARK	SCORE
A	20	
B	40	
C	40	
TOTAL	100	

SECTION A (20 MARKS)

Attempt all questions in this section. Write the letter corresponding to your chosen correct answer to each question in the box provided at the right side of the paper.

1. The tracheal system of insects is used for

- A. Gaseous exchange
- B. Blood circulation
- C. Holding wings in place
- D. Contraction of muscles

2. A student examined preparation of cells under a microscope and concluded that it was from animal material. Which one of the following observations would help the student to make that conclusion?

- A. Presence of large nuclei located away from the centre of the cell.
- B. Absence of starch grains and nucleus.
- C. Absence of cell walls and chloroplast
- D. Presence of large nuclei with much cytoplasm.

3. When two organisms live together to their mutual benefit, the relationship is called

- A. parasitism
- B. symbiosis
- C. commensalism
- D. saprophytism

4. A plant cell is said to be flaccid when:

- A. it contains high concentration of starch
- B. the cell contains sufficient cell vacuole for its size
- C. sufficient water has entered the cell so that the cell membrane exerts pressure on the cell wall
- D. the cell membrane is separated from the cell wall.

5. The graph in Figure 1 shows the change in estimated average of dry mass throughout the growth of a pea plant from germination. Which one of the points marked on the graph shows the time when food reserves in the seeds are almost used up?

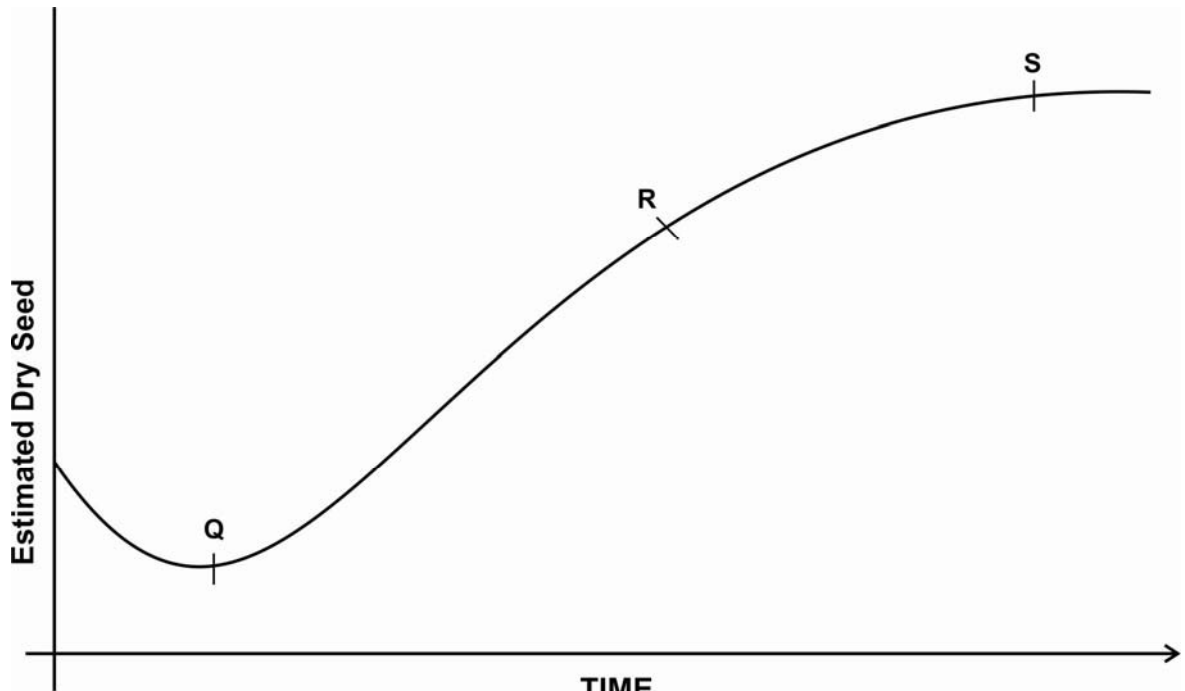

Figure 1

- A. P
- B. Q
- C. R
- D. S

6. The stage in the life cycle of an insect in which no growth takes place but there is a drastic reorganization of tissue is the

- A. pupa
- B. instar
- C. egg
- D. imago

7. A man of blood group A married a woman with blood group B. To which blood groups would their children belong?

- A. A or B
- B. O or B
- C. A or O
- D. B or AB

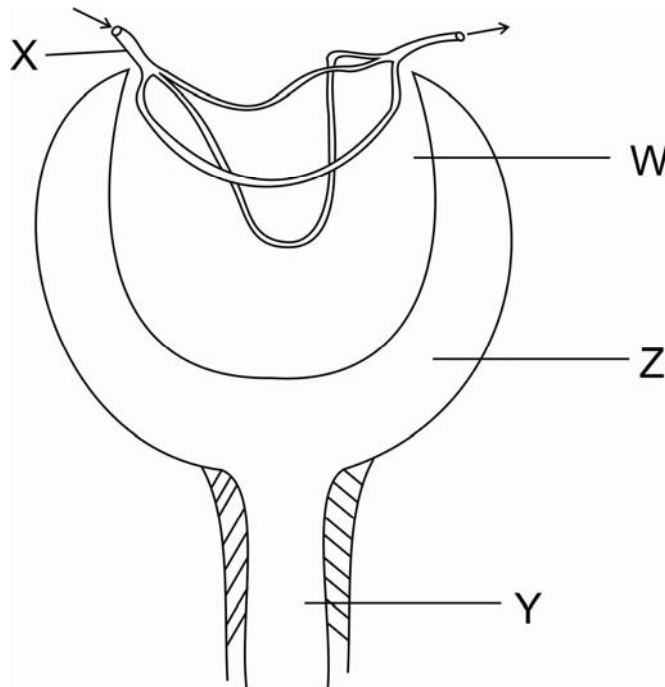

Figure 2

8. Figure 2 above is a diagram of a part of a typical kidney. In which part of the kidney is the protein concentration at zero?

- A. Y
- B. Z
- C. C
- D. X

9. In classifying living organisms, species, genus, order, class and phylum are used. Which one of the following describes a species?

- A. A population of many classes of organisms
- B. Living organisms on the same environment
- C. A population of organisms that depend on each other
- D. A group of organisms that breed together successfully

10. A good loam soil has certain distinct properties. Which one of the following is the most correct about loamy soil?

- A. The soil holds enough water for plant growth
- B. There is a large proportion of aerobic bacteria
- C. There is a good range of soil particles, size and humus contents
- D. There are sufficient mineral salts for plant growth

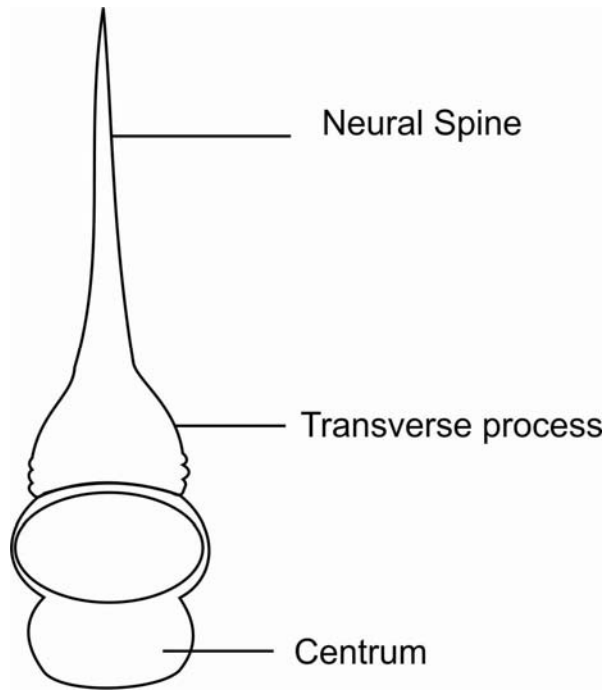

Figure 3

11. Which of the statements concerning the bone in Figure 3 above is false?

- A. It is a thoracic vertebra
- B. It has a short neural spine
- C. The function of the neural spine is to act as an anchorage for back muscles
- D. It is found in all vertebrates

12. When a mammal is breathing-in, its thoracic cavity expands. This is brought about by:

- A. the expansion of the lungs
- B. contraction of the inter-coastal muscles and the Diaphragm muscles
- C. relaxation of inter-coastal muscles and relaxation of diaphragm

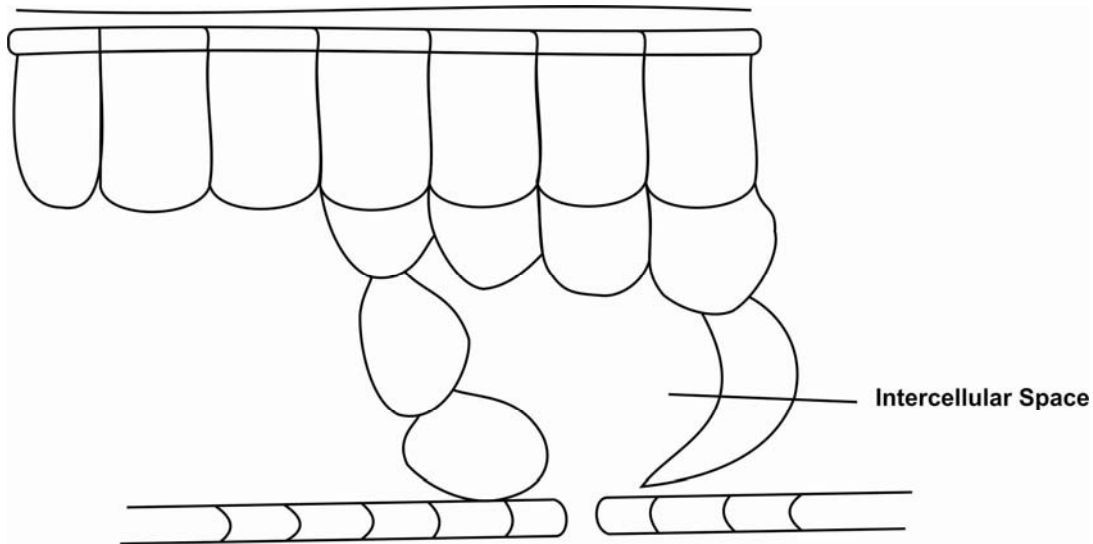

Figure 4

13. The diagram in Figure 4 above shows the main part of a cross section of internal structure of a leaf. The function of the intercellular space is to:

- A. bring in oxygen and give out carbon dioxide
- B. keep the stomata aerated
- C. bring water to the leaf cells
- D. provide an easy passage through which carbon dioxide and oxygen can diffuse

14. The major aim of classifying of organisms is to identify the organisms, which involves giving names to them. Naming of organisms is called

- A. taxonomy
- B. taxonomic ranks
- C. nomenclature
- D. dichotomous

15. Darwin is best known for his work on evolution of species. According to him evolution is a

- A. factor support by experimental investigation
- B. theory support by factual evidence
- C. logical explanation based on pure reasoning
- D. hypothesis which could be provided by experimental investigations

16. "Fermentation" of sugar to alcohol by yeast differs from most cellular oxidative processes in that it does not

- A. require enzymes
- B. release energy
- C. require oxygen
- D. form carbon dioxide

17. The diagram in below shows a plasmolysed plant cell that has been transferred into water. What is likely to happen to the cell if it is left for 1 ½ hours?

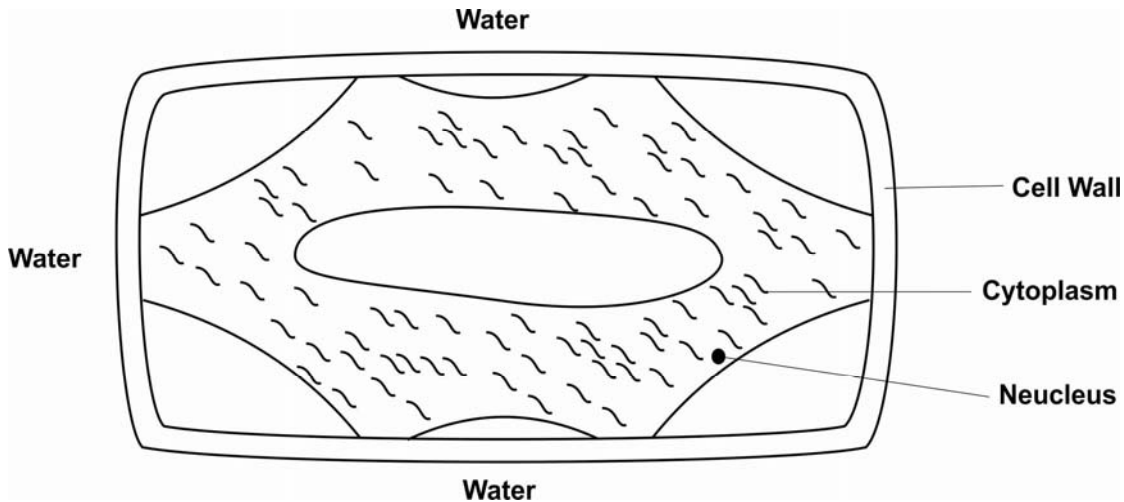

Figure 5

- A. It will lose water to the surrounding and decrease in size
- B. It will absorb water from the surrounding and increase in volume
- C. It will not experience any change in size
- D. The vacuole will shrink and disappear altogether

18. The branch of Biology that assigns names to all organisms is known as:

- A. classification
- B. taxonomist
- C. evolution
- D. taxonomy

19. The paths followed by impulses during a reflect action are

- (1) muscles
- (2) sensory neurone
- (3) association neurone
- (4) motor neurone

The correct order followed by impulses is

- A. 2, 3, 4, 1
- B. 3, 2, 4, 1
- C. 1, 4, 3, 2
- D. 3, 4, 2, 1

20. Hygroscopic movements mostly occur in

- A. insect
- B. moss and ferns
- C. amphibian
- D. herbaceous plants

SECTION B

Answer all the questions in the spaces provided.

21. (a) Define symbiosis (1 mark)

.....
.....
.....

(b) Explain the symbiotic relationship between Rhizobium bacteria in root nodules and leguminous plants (2 marks)

.....
.....
.....
.....
.....

(c) How does man benefit from the relation in (b) (2 marks)

.....
.....
.....
.....

(d) Give two examples of symbiosis (1 mark)

.....
.....
.....
.....

(e) Distinguish between symbiosis and commensalism (1 mark)

.....
.....
.....
.....

22. The diagram in below is a transverse section of a typical leaf.

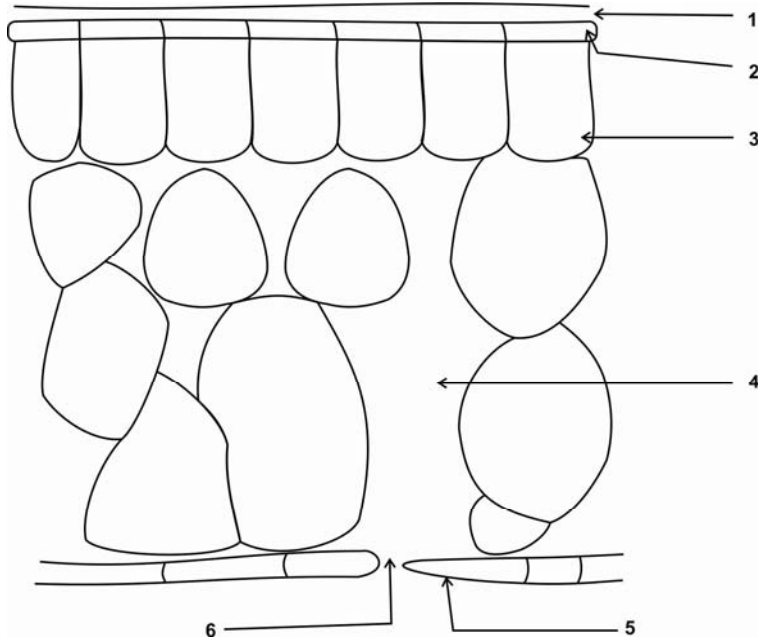

Figure 6

(a) Label leaf parts 1-6 (3 marks)

- | | |
|---------|---------|
| 1. | 4. |
| 2. | 5. |
| 3. | 6. |

(b) Give the importance of parts 3, 4 and 7 (1½ marks)

- (i)
-
-
- (ii)
-
-
- (iii)
-
-

(c) From the diagram state three structural adaptations of the leaf for photosynthesis (1½ marks)

- (i)
-
-
- (ii)
-
-
- (iii)
-
-

(d) What is the benefit of a large surface area of photosynthetic leaf? (1 mark)

-
-
-
-

23. below shows the inheritance of sex in human beings. Study the figure and answer the questions that follow

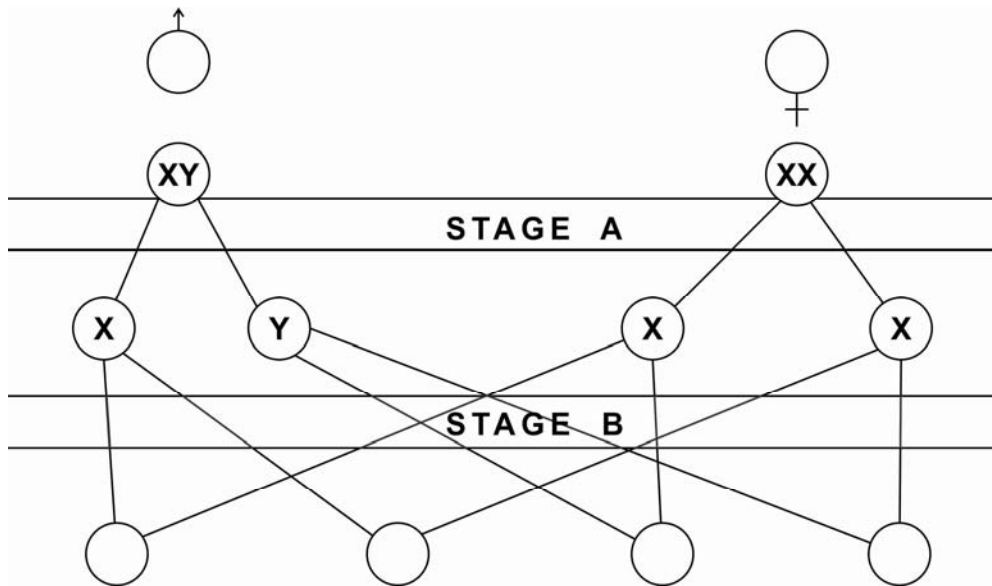

Figure 7

(a) (i) Name the cell division that takes place at Stage A (½ mark)
.....
.....
.....

(ii) Name the reproductive process which takes place at B (½ mark)
.....
.....
.....

(iii) Fill the gametes in the empty circles (2 marks)

(iv) Fill the symbols for the sex of the offspring in the empty circles (4 marks)

(b) What is the percentage of the offspring in terms of their sex? (1 mark)
.....
.....

(c) What is the name given to chromosome number in:

(i) Gametes (½ mark)
.....
.....

(ii) Zygote (½ mark)
.....
.....

(d) What happens to the sex chromosomes

(i) during meiosis (½ mark)
.....
.....
.....
.....

(ii) during fertilization (½ mark)

.....
.....
.....
.....

24. The diagram in Figure 8 below shows a longitudinal section of a flower.

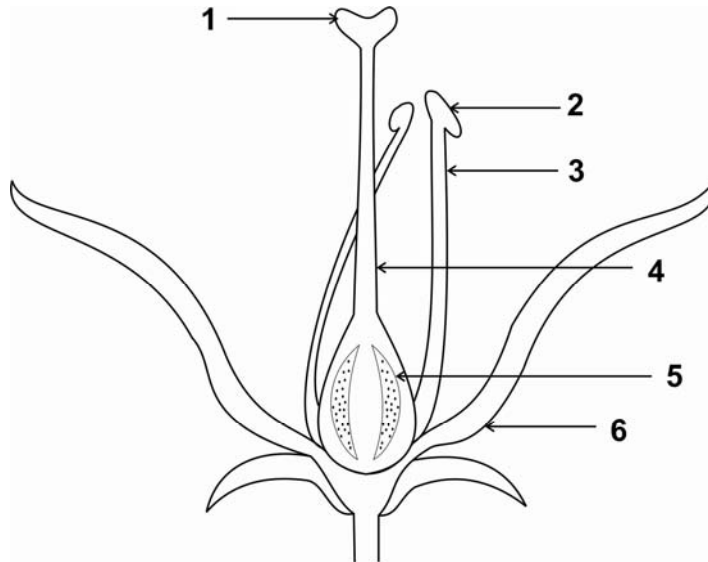

Figure 8

(a) Label parts 1 -6 (3 marks)

1.	4.
2.	5.
3.	6.
4.	6.

(b) Give functions of parts 1 and 2

Function of part 1 (1½ marks)

.....
.....
.....

Function of part 2

(1½ marks)

.....
.....
.....

(c) With a reason, suggest how this flower can be pollinated

.....
.....
.....

25. Study the apparatus set up in Figure 9 below

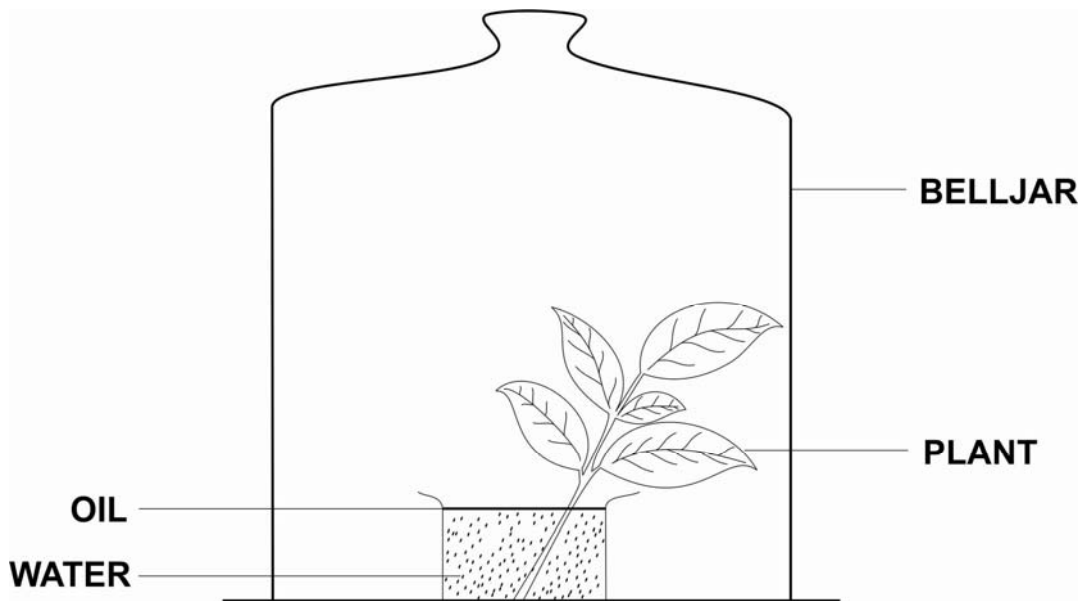

Figure 9

(a) What is the purpose of the experiment set up in Figure 9? (2 marks)

.....
.....
.....

(b) What purpose is served by oil? (1 mark)

.....
.....
.....

(c) What will you notice in the bell jar after some hours? (2 marks)

.....

(d) How would you confirm the presence of that substance? (1 mark)

.....

26. A victim of excessive blood loss can recover by blood transfusion in which blood from one person, the donor, is transferred into the patient's blood stream. The table below shows how the exercise can be carried out. Capital letters represent blood groups or antigens, small letters antibodies, minus sign compatibility, and plus sign agglutination.

	Ab	Ba	Abnil	Oab
Ab	-	+	I	-
Ba	+	II	+	-
Abnil	III	-	-	-
Oab	+	+	+	IV

RECIPIENT

(a) Give the respective signs left out to complete the table

- (i) Sign for I (½ mark)
- (ii) Sign for II (½ mark)
- (iii) Sign for III (½ mark)
- (iv) Sign for IV (½ mark)

(b) (i) State the advantage and disadvantage of having blood group O

Advantage

 (1 mark)

Disadvantage
.....
..... (1 mark)

(ii) What advantage does a person with blood group AB have?

Advantage
.....
..... (1 mark)

(c) Mention two other factors that need to be considered during transfusion exercise apart from the reaction of the recipient's antibodies on the donors' antigens.

(i)
.....
..... (½ mark)

(ii)
.....
..... (½ mark)

(d) A man of blood group A marries a blood group B woman. What blood groups would be expected in their offspring?

.....
.....
..... (1 mark)

SECTION C

Answer only two questions including question number 27 which is compulsory.

27. (a) (i) What is seed dormancy? (2 marks)
- (ii) Briefly explain the importance of seed dormancy in the life cycle of a plant (4 marks)
- (b) Explain what happens to the protein and carbohydrates stored in seeds during germination. (10 marks)
- (c) Explain how seed dormancy can be broken. (4 marks)
28. (a) What is understood by the term metamorphosis? (1 mark)
- (b) Give six features which are common to adult insects. (3 marks)
- (c) With the help of a diagram explain the life cycle of a housefly (10 marks)
- (d) Briefly explain how gaseous exchange takes place in insects (6 marks)
29. (a) Explain the following terms:
- (i) Analogous structures (2 marks)
- (ii) Adaptive radiation (4 marks)
- (b) Briefly explain four evidences that support organic evolution (8 marks)
- (c) Give two advantages of organic evolution theory (2 marks)
- (d) Explain how human being influence the process of evolution (6 marks)
30. (a) Distinguish between simple and condition reflex action (6 marks)
- (b) Explain how the human eye accommodates light for clear vision in
- (i) dim light (2 marks)
- (ii) the case of a distant object (2 marks)

- (c) Show two functional similarities between the endocrine and nervous system (4 marks)
- (d) Give 3 difference between tropic and reflex responses (3 marks)
- (e) Name three types of responses found in plants and give one example in each. (3 marks)

THE END



**GOVERNMENT OF SOUTHERN SUDAN
 MINISTRY OF EDUCATION
 EXAMINATIONS SECRETARIAT**



**SOUTHERN SUDAN CERTIFICATE OF SECONDARY EDUCATION (S.S.C.S.E)
 EXAMINATIONS**

Nov./Dec. 2010

**044/2 GENERAL SCIENCE
 PAPER TWO
 2 HOURS 30 MINUTES**

NB: NAME (CAPITAL LETTERS):

INDEX NUMBER **SIGNATURE**.....

Must be written on all answer booklets used.

INSTRUCTIONS

Read the instructions carefully before answering any question.

1. This paper consists of three sections: A, B and C.
2. Candidates are required to answer a total of **five** questions, choosing at least **one** from each section: A, B and C.
3. All questions in all the sections carry equal marks (20 marks each).
4. Answers to these questions must be written on a separate sheet of paper provided.
5. Unnecessary crossings of answers and illegible handwriting is discouraged.

SECTION A

- 1 (a) (i) Mention any five components of blood. 5 marks
(ii) Explain any three functions of blood 6 marks
- (b) Although the walls of left ventricle are thicker than the walls of the right ventricle, the volumes of the ventricles are the same. Why is this necessary? 3 marks
- (c)

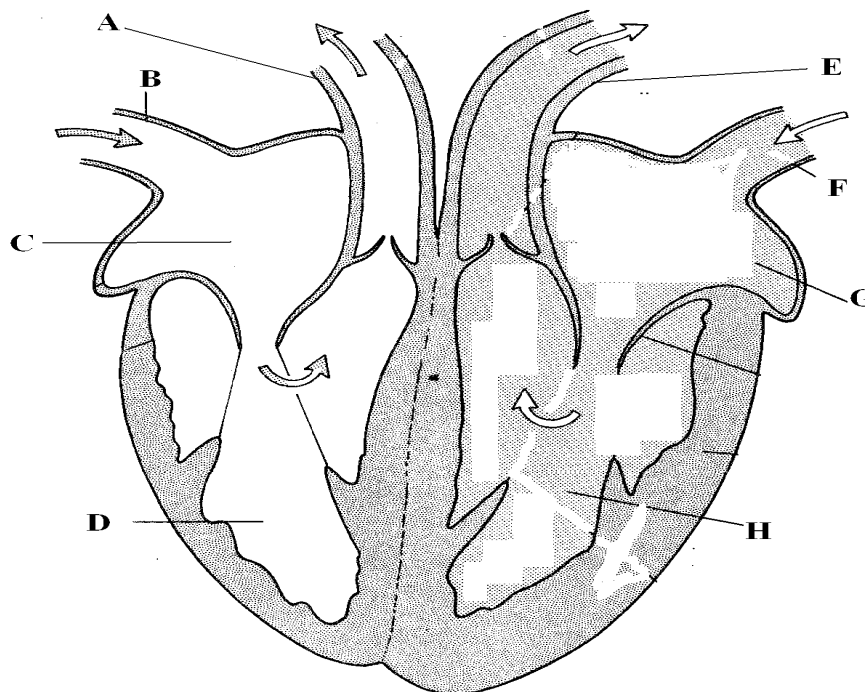

DO NOT DRAW THE DIAGRAM

- (i) Name the parts of the heart A,B, C, D, E, F, G, H. 4 marks
(ii) Where does blood leaving the heart from the following parts go to? 2 marks
-Part A.
-Part E.
2. (a) When carbon containing substance (like wood) are burnt in limited supply of air,
(i) mention the main product of the reaction. 1 mark
(ii) State three physical properties of charcoal. 3 marks
(iii) Explain two uses of charcoal. 4 marks
- (b) When methane (CH₄) is burnt in plentiful air, carbon dioxide and water are produced. Write a balanced chemical reaction equation for the reaction. 3 marks

- (c) In the carbon cycle shown below, name the four processes and the product.

6 marks

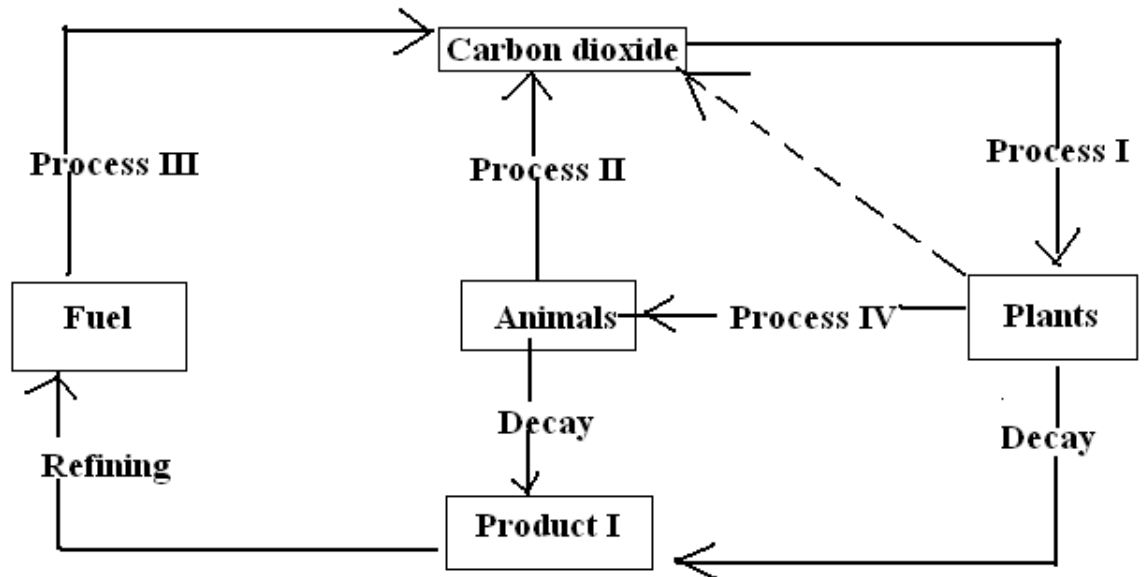

- (d) Mention any three uses of diamond. 3 marks
3. (a) (i) What is meant by electric current? 2 marks
(ii) What is the SI Unit of electric current? 1 mark
- (b) (i) Define electrical Resistance and state its SI Units. 2 marks
(ii) A dry cell has an e.m.f of 1.5 V. When the voltage is measured using a voltmeter directly across its terminals in a closed circuit, the reading is less than 1.5 V. Explain why there is a drop in the voltage. 6 marks
- (c) A bulb is rated 12 V, 36 W. When used on a 12 V supply, find
(i) the current it will take. 3 marks
(ii) the amount of energy the bulb uses in 30 minutes 3 marks
(iii) the resistance across the bulb filament. 3 marks

SECTION B

4. (a) The following diagram shows the main parts of a flower (You are not required to draw the flower).
(i) Label the parts of the flower, A, B, C, D, E, F, G, and H below. **4 marks**

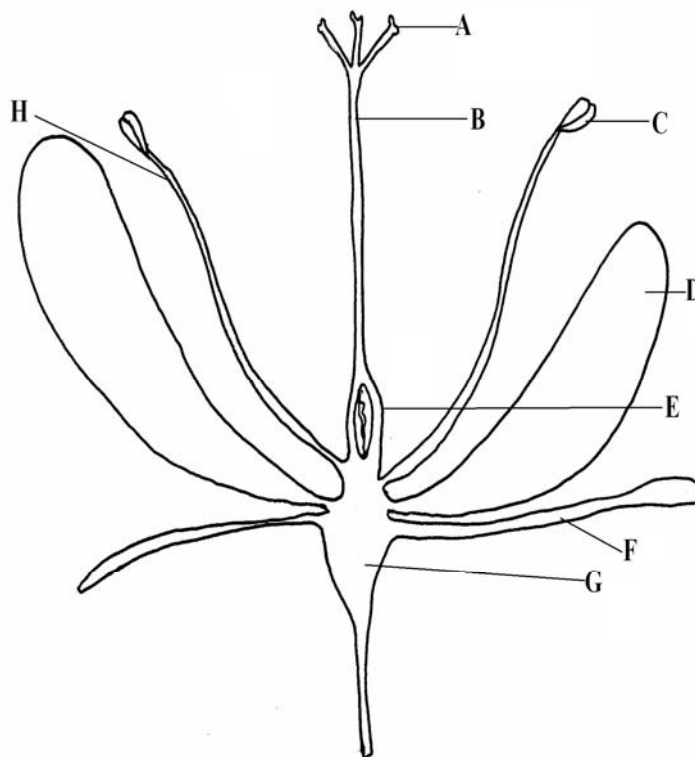

- (ii) What does part E develop into after fertilization? **2 marks**
- (b) Explain four characteristics of wind pollinated flowers. **8 marks**
- (c) What features make a fruit or seed suitable for dispersal by animals? **6 marks**
5. (a) Explain the principle of fractional distillation. **3 marks**
- (b) With respect to the above principle, describe how the different products of crude oil are refined. **7 marks**
- (c) How is crude oil formed from dead organic matter? **6 marks**
- (d) Mention the hydrocarbons that are present in natural gas. **4 marks**

6. (a) Define Pressure and state its SI Unit. **2 marks**
- (b) A metallic cuboid of mass 240 kg has dimensions 4 m x 3 m x 2 m. Calculate the pressure that it exerts when resting on,
- (i) the largest area. **3 marks**
- (ii) the smallest area. **3 marks**
- (iii) compare the pressures exerted in (i) and (ii) above and explain your observations. **2 marks**
- (c) Describe with the aid of a diagram, an experiment to show that pressure in liquids increases with depth. **5 marks**
- (d) (i) State Pascal's Principle of transmission of pressure in a closed system of liquids. **1 mark**
- (ii) In a hydraulic Press, a ram of piston with area 2 m^2 is to carry a car of weight 250,000 N. How much force should be exerted on the piston of area 0.04 m^2 in order to be able to lift the car? **4 marks**

SECTION C

7. (a) What is an electrolyte? **1 mark**
- (b) In the electrolysis of sodium hydroxide using carbon electrodes, explain the reactions at the electrodes and the liberated products. Write the chemical equations for the reaction. **7 marks**
- (d) Sodium hydroxide is the by-product in the electrolysis of sodium chloride using a mercury cathode. Write the chemical details of the reactions that take place at each electrode. **12 marks**
8. (a) (i) Dikun, a nurse, injects a patient using an injection syringe and accidentally pierces herself with the same syringe needle. Explain how this exposes Dikun to the risk of acquiring HIV. **5 marks**
- (ii) Explain three other ways, in which the HIV can be transmitted from one person to another. **4 marks**
- (b) Explain three main sexual practices (behaviours) that can reduce the risk of contracting HIV/AIDS. **6 marks**
- (d) Why is it said that the practice of greeting using hand (handshake) cannot make one to acquire HIV/AIDS? **3 marks**

9. (a) A tin of Iron filings got poured into a container of sand. Explain how one can separate the filings from the sand. 4 marks
- (b)

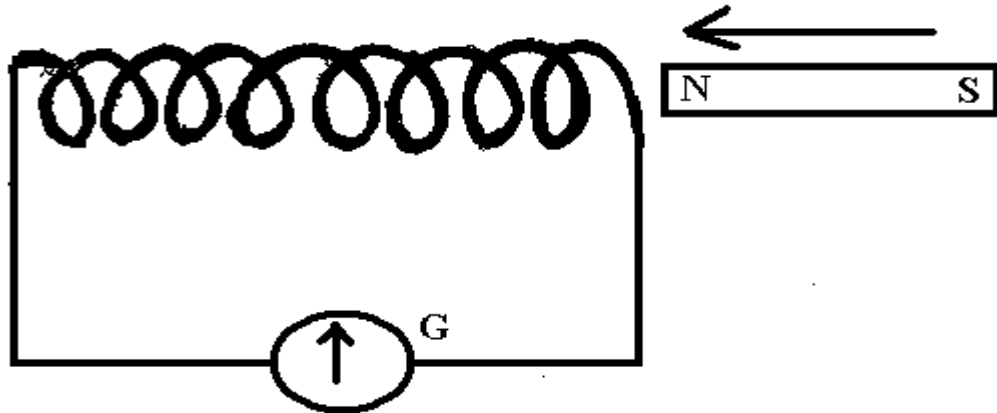

A bar magnet is pushed inside a coil, which is connected to a Galvanometer as shown in the diagram above. Explain what is observed. 6 marks

- (c) Explain how the magnetic properties of the earth helps scientists in finding their position around the earth. 6 marks
- (d) Sketch the magnetic field patterns of a bar magnet. 4 marks

END



Republic of South Sudan
Ministry of General Education & Instruction
Secretariat of Examinations

044/1
General Science Paper 1
TIME: 2 ½ Hours.

SOUTH SUDAN CERTIFICATE OF SECONDARY EDUCATION (S.S.C.S.E)

EXAMINATIONS

Nov/Dec, 2011

NAME (IN CAPITAL LETTERS): _____

INDEX NUMBER: _____ **Signature:** _____

INSTRUCTIONS:

NB: WRITE YOUR NAME, INDEX NUMBER CLEARLY IN CAPITAL LETTERS AND SIGN.

Read the instructions carefully before answering any question.

1. This paper consists of two sections, A and B. Section A consists of 30 multiple choice questions (30 marks) and section B consists of 6 structured questions (70 marks).
2. All questions are compulsory.
3. Answers to questions in section A are to be written in the box provided on the right hand side of each question and those to section B to be written in the spaces provided in the question paper.
4. You will lose marks for untidy work and use additional writing paper besides this.

TURN OVER

SECTION A:

1. The chemical formula for rust is

- A. CaCO_3
- B. $\text{Fe}_2\text{O}_3 \cdot x\text{H}_2\text{O}$
- C. MgCO_3
- D. $\text{CuSO}_4 \cdot x\text{H}_2\text{O}$

2. The process by which diesel fraction in petroleum refining is converted into petrol is known as;

- A. Distillation.
- B. Crystallisation.
- C. Hydro carbonation.
- D. Hydrogenation.

3. Which of the following method of birth control has the **highest failure rate**?

- A. Condom.
- B. Diaphragm.
- C. Coitus interruption.
- D. Spermicidal form.

4. Which of the following graphs describes a body that moves with uniform velocity?

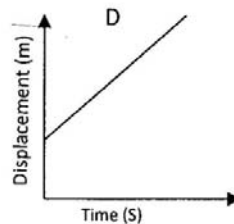
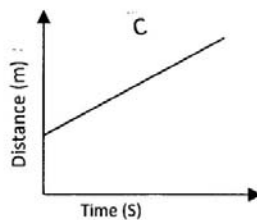
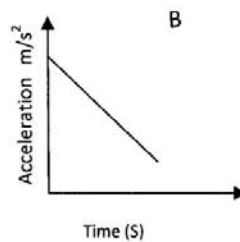
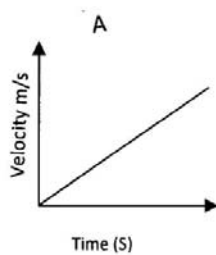

5. Penicillin is no longer effective against some infectious diseases caused by some bacteria. Why is this true? This is because:

- A. The diseases have been wholly eliminated.
- B. Some persons are allergic to penicillin.
- C. The bacteria have developed some resistant strains.
- D. Does not kill the bacteria but makes them active.

6. A piece of wood weighs 102 N in air, 64 N in water and 18 N in sulphuric acid. What is the relative density of the sulphuric acid?

- A. 0.6
- B. 0.4
- C. 2.1
- D. 1.7

7. During pregnancy, the group substances that pass from the mother to the embryo are:

- A. oxygen, glucose and nitrogen.
- B. oxygen, glucose and amino acids.
- C. carbon dioxide, amino acid and mineral salts.
- D. oxygen and glucose only.

8. The standard test for oxygen gas is;

- A. It re- lights a glowing splint.
- B. 'Pops' with a burning splint.
- C. Extinguishes a burning splint.
- D. Turns limewater milky.

9. The following information is collected on 3 metals X, Y and Z with regards to their reactions with cold water, steam and dilutes acids.

Metal	Reaction with water	Reaction with steam	Reaction with dilute acid.
x	No reaction.	Slow reaction	Rapid reaction
y	Reacts.	Rapid reaction	Rapid reaction.
z	Reacts with fire	Explosive.	Explosive.

The metals arranged in order of reactivity from least reactive to most reactive are:

- a. XYZ.
- b. YXZ.
- c. ZYX.
- d. ZXY.

10. The table below provides information on two isotopes of element X (not its real chemical symbol).

Isotope.	Number of protons.	Number of neutrons.	Number of electrons.	Relative abundance.
X.	17	18	19	75%
X	17	20	17	25%

Which is the mass number (nucleon number) of the most abundant isotope?

- a. 35.
- b. 39.
- c. 17.
- d. 75.

11. Pressure is defined in terms of:

- a. Force/area.
- b. Force/mass
- c. Force/ volume
- d. Force/length.

12. Which of the following substances is used to soften hard water?

- A. Calcium carbonate.
- A. Zinc carbonate.
- B. Ammonium (II) carbonate.
- C. Sodium carbonate.



13. An electric heater supplies 12 KJ of heat in 20 minutes. What is the power rating?

- A. 10 W
- B. 600 W
- C. 6 W
- D. 36 KW

14. The electronic configuration of element Y is 2:8:2 and that of element Z is 2:7. The most likely formula for a compound of YZ is;

- A. YZ
- B. Y₂Z
- C. YZ₂
- D. Y₂Z₃.

15. Figure 1 shows a longitudinal section through a maze grain.

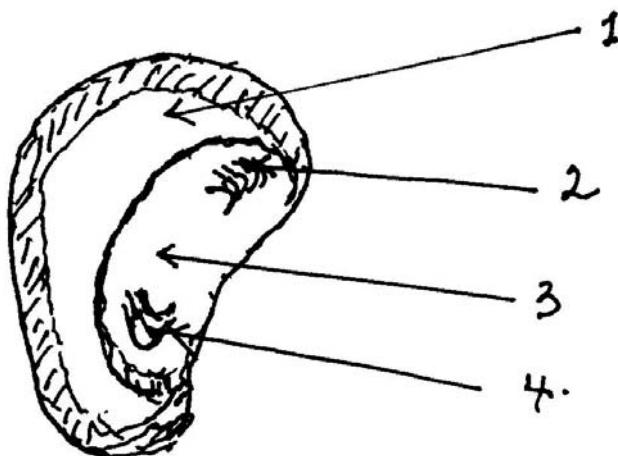

Which of the parts of the grain is used as food by the germinating plant?

- A. A.1
- B. B.2
- C. C.3
- D. D.4

16. Which of the following is/ are true about molecular theory of magnetism?

- (i) Breaking a magnet into two, results into the formation of 2 magnets.
- (ii) Heating and hammer destroys the magnetism.
- (iii) The poles of a magnet are of equal strength.
- (iv) The line of force travel from a north pole towards the south pole.

- A. if statements (i) (ii) and (iii) are true.
- B. if statements (i) and (ii) only are true.
- C. if statements (ii) and (iii) only are true.
- D. if statements (iii) and (v) only are true.

17. The gaseous hydrocarbon P contains 40% hydrogen mass at STP. Calculate the empirical formula of P (C=12, H=1).

- A. CH₂
- B. CH₃
- C. C₂H₃
- D. CH.

18. Which of the following enzymes acts best in an acidic medium?

- A. Pepsin.
- B. Peptidase.

C. Trypsin.

D. Lipase.

19. Which of the following are all brittle materials?

A. Leather, rubber and thread.

B. Clay, glass and wood.

C. Glass, cast iron and stone.

D. Rubber, polyester and copper wire.

20. Identical twins are produced as a result of:

A. One egg released, fertilised and splits into two.

B. One egg released and fertilised by two sperms.

C. One egg released splits and fertilised by separate sperms.

D. Two eggs released and each fertilised by a separate sperm.

21. Which of the following substances does NOT conduct electricity?

A. Aqueous sodium bromide.

B. Molten potassium bromide

C. Aqueous hydrogen bromide.

D. Solid lead copper (II) bromide.

22. Which of the following does not reduce friction?

A. Heating.

B. Greasing.

C. Use of ball bearing.

D. Oiling.

23. Which of the activities below will promote the transmission of HIV?

A. Wife sharing.

B. Shaking hands.

- C. Hugging.
- D. Sex with proper use of condom.

24. What is the combined resistance in the circuit shown below?

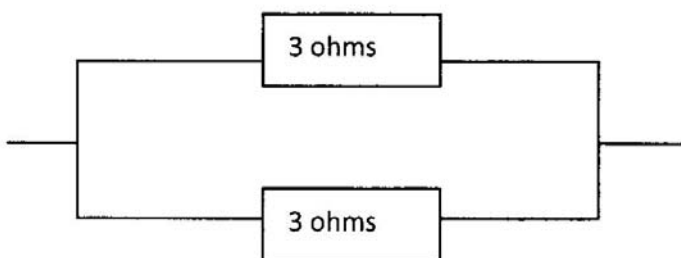

- A. 6Ω
 - B. 3Ω
 - C. $\frac{1}{2} \Omega$
 - D. $\frac{1}{3} \Omega$.
25. Total internal reflection occurs when the angle of incidence in a denser medium is.
- A. Equal to critical angle.
 - B. Less than critical angle.
 - C. Equal to the angle of reflection
 - D. Greater than the critical angle.
26. Which of the following reagents is used to test for water?
- A. Cobalt (II) oxide.
 - B. Copper (II) sulphate.
 - C. Hydrated copper (II) sulphate.
 - D. Anhydrous copper (II) sulphate.
27. The products of photosynthesis are:

A. Glucose and carbon dioxide.

B. Oxygen and starch.

C. Oxygen and glucose.

D. Carbon dioxide and water.

28. A passenger will be thrown forward when a car is suddenly brought to a stop. This is because:

A. Conservation of momentum.

B. The law of inertia.

C. The body prefers to move forward.

D. The third law of motion.

29. An orange tastes sour because the juice from it contains:

A. Bases.

B. Acids.

C. Alkalis

D. Little water.

30. The process of maintaining a suitable quantity of water in living cells is called.

A. Excretion.

B. Hydration

C. Perspiration.

D. Osmo-regulation.

SECTION B.

Attempt all the questions.

Write your answers in the in the spaces provided.

31. (a) Electric symbols are shown below:

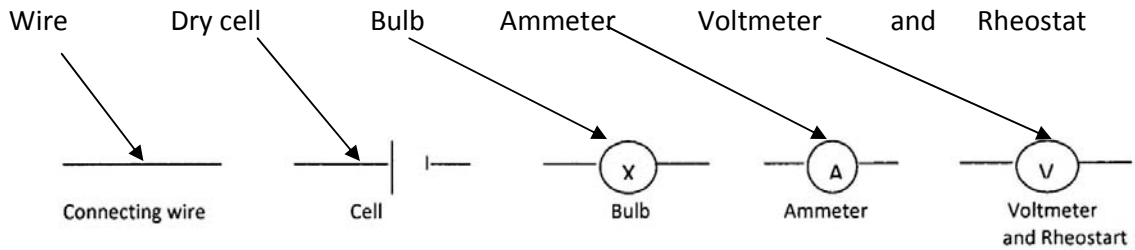

Use the symbols above to draw a diagram of current which would allow the bulb to light, measure the current and voltage across the bulb. (4 marks)

(b) State the function of the above instruments.

- (i) Switch..... (1 mark)
- (ii) Dry cell..... (1 mark)
- (iii) Ammeter..... (1 mark)
- (iv) Rheostat..... (1 mark)

(c) In Fig. 2 below, circuit R_1 and R_2 are connected across a 12V supply.

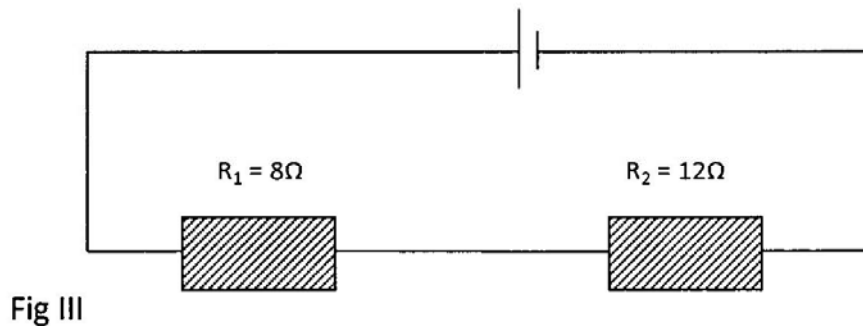

Fig III

(i) What is the total current through system?

(2 marks)

32. (a) When chlorine is bubbled into water it forms an acidic solution.

(i) Which of the pH values would you expect the solution to have? 2, 7, 8, 12

PH?.....
..... [1 mark]

(ii) Write an equation to show how the acid would ionise in water?

.....
.....(2 marks)

(b)(i) State the differences between an acid and an alkaline.

.....
..... (2marks)

(ii) Describe what happens when a mixture of the acid and concentrated nitric acid is heated.....

.....
.....
..... (5 marks)

33. (a) Fig. 3 shows the vertical section of a mammalian heart.

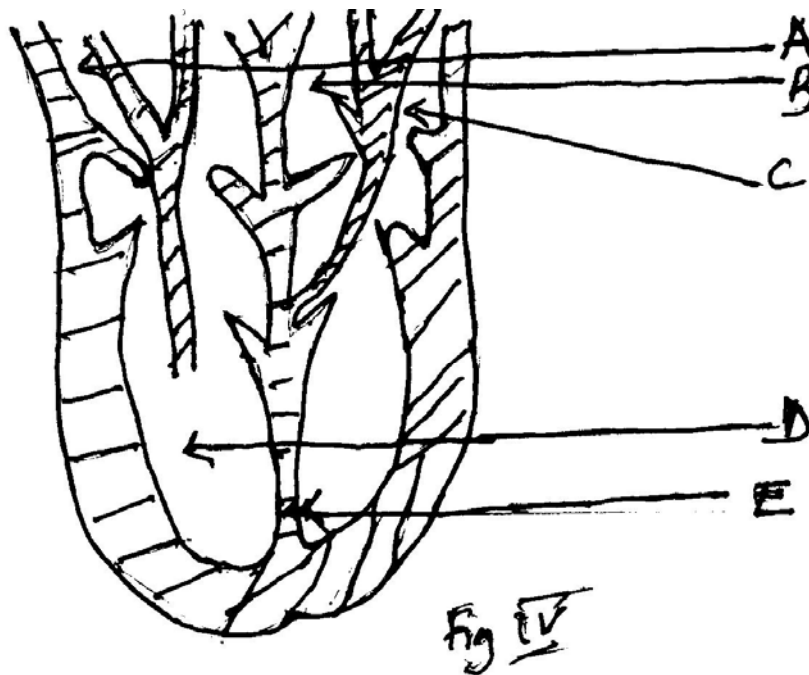

(i) Name the parts labelled A-E

(5 marks)

.....
.....
.....
.....
.....
.....

(ii) State two differences between blood vessel A and B.

.....
.....
..... (2 marks)

(iii) What is the biological importance of E in the mammalian heart during the blood circulation?

.....
.....
..... (1 mark)

(b)(i) State two diseases associated with the circulatory system.

.....
.....
..... (2 marks)

(ii) How is the mammalian heart adapted to its function?

.....
.....
.....
..... (3 marks)

34.

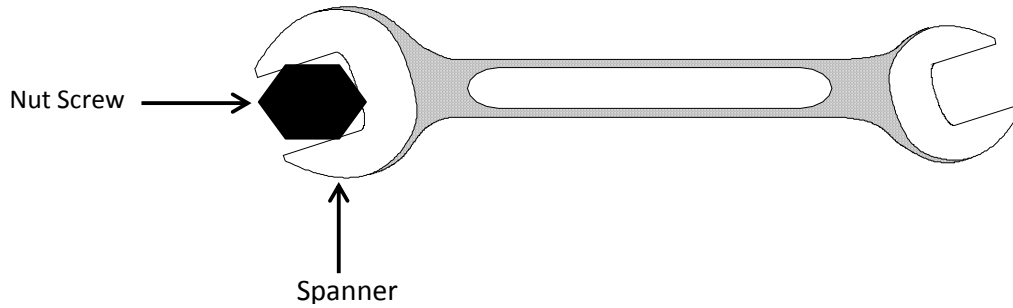

(a) On the diagram,

- (i) Label the position of the pivot.....[2 mark]
- (ii) The force applied to the spanner with an F.....[1 mark]
- (iii) If the force applied to the spanner is not enough to remove it. Suggest one way by which the force applied to the spanner could be increased. [3 mark]

b) Name the organs responsible for the following functions in the digestive system

- 1) Digestion.....
- 2) Ingestion.....
- 3) Egestion.....
- 4) Absorption.....

[4 marks]

35. (a) (i) What two substances are needed to make iron rust.

.....
..... (2 marks)

(ii) Chemical name for rust. (2marks)

(iii) Chemical formula for rusting..... (1 mark)

(b) Suggest two ways by which you would prevent rusting, say of clean Iron nails.

.....
..... (2 marks)

(c) (i) Name the major gases in the atmosphere other than nitrogen.

.....
..... (2 marks)

(ii) Outline three properties of the nitrogen gas.

.....
.....
.....(3 marks)

36. The table below shows some essential substances in the man diet, the foods from which we get them and their functions. Complete the blank space in the table below:.

Substance.	Food.	Function in the body.
	Orange juice.	Making connective tissue.
Vitamin D		Making bones.
	Red meat	Making red blood cells

(3 marks)

(b) (i) define an enzyme.....

..... (1 mark)

(ii) Briefly describe how an enzyme acts on a named food substrate using the key and lock hypothesis. (Diagram necessary).

.....
.....
.....

..... [6 marks]

THE END



Republic of South Sudan
Ministry of General Education & Instruction
Secretariat of Examinations

044/2
GENERAL SCIENCE
PAPER TWO
TIME: 2 ½ HOURS.

SOUTH SUDAN CERTIFICATE OF SECONDARY EDUCATION (S.S.C.S.E)
EXAMINATIONS
Nov/Dec, 2011

INSTRUCTIONS.

NB: WRITE YOUR NAME, INDEX NUMBER CLEARLY IN CAPITAL LETTERS AND SIGN ON ALL BOOKLETS USED.

Read the instructions carefully before answering any question.

1. The paper consists of three sections A, B and C.
2. Candidates are required to answer a total of **five** questions, choosing at least one from each of section A, B and C.
3. All questions in each section carry equal marks.
4. Answers to these questions must be written on separate sheets of paper provided.
5. Unnecessary crossings and illegible handwriting may lead to loss of marks.

TURN OVER

SECTION A.

1. (a) Give the meaning of the following terms used to describe flowers:

- I. Bisexual. (2 marks)
- II. Corolla. (2 marks)
- III. Pistil. (2 marks)
- IV. Androecium. (2 marks)

(b) (i) Draw a well labelled diagram of a flower. (5 marks)

(ii) State at least 5 characteristics of flowers pollinated by bees. (5 marks.)

(iii) After fertilisation, which parts of a flower develop into seeds and fruits? (2 marks).

2. (a) (i) Aids and gonorrhoea are sexually transmitted diseases. Complete the table below giving the type of microbes which cause each disease and how the disease may be treated to destroy the microbe.

Disease.	Type of microbe.	Treatment.
Aids.		
gonorrhoea		

(ii). Differentiate between HIV and aids. (4 marks)

(iii). Explain at least four ways in which the HIV virus can be transmitted from one person to another. (4 marks)

(b)(I) What are the main sexual practises that reduce the risk of contracting HIV/AIDS? (2 marks)

(ii) How can antiretroviral (ARV) drugs benefit a sex worker tested positive with the HIV virus. (3 marks)

(c) One of the myths about HIV/AIDS reads ‘HIV/AIDS is for the rich’. Outline 3 other myths about HIV/AIDS in your community. (3 marks)

3. (a) All living organisms have 7 basic life processes. List 6. (6 marks)

(b) (i) if 150 g of a cereal food contains 30g fibre. What is the percentage of the fibre in the cereal? (1 mark)

- (ii) Why must human beings include fibre in their meal food?
(1 marks)
- (iii) Name 3 diseases which may result if there is not enough fibre in human food.
(3 marks)
- (c) Describe how a mammalian lung is adapted for gaseous exchange. (Diagram not necessary)
(8 marks)

SECTION B.

4. (a) Give two harmful effects on the environment of limestone quarrying.
(2 marks).
- (b) The limestone (calcium carbonate) is heated in a kiln and changed into carbon dioxide and a white solid.
- (i) Write the equation for the reaction.
(2 marks)
- (ii) In the laboratory, how would you indentify carbon dioxide?
(2 marks)
- (iii) Calcium hydroxide which is made from limestone reacts with water to give an alkaline solution. What would you use to find the PH of the solution?
(1 mark)
- (c) Calcium hydroxide neutralises nitric acid. Give the formula of the salt produced in the reaction.
(3 marks)
- (d) (i) Describe how you would show by a chemical test that graphite is made of carbon atoms
(6 marks)
- (ii) State three properties f graphite.
(3 marks).
5. (a) Reduction is widely used in the manufacturing process. Ammonia is manufactured from nitrogen and hydrogen by Haber process.
- (i) Write a balanced symbol equation for the reaction.
(2 marks)
- (ii) Explain why the reaction is described as reduction.
(1 mark).

SECTION C:

7. (a) (i) what is meant by an electromagnetic field? (2 marks)

(ii) Describe briefly how to determine the poles of a strong magnet. (8 marks)

(b) The diagram below shows a simple electromagnet being used to pick up a drawing pin.

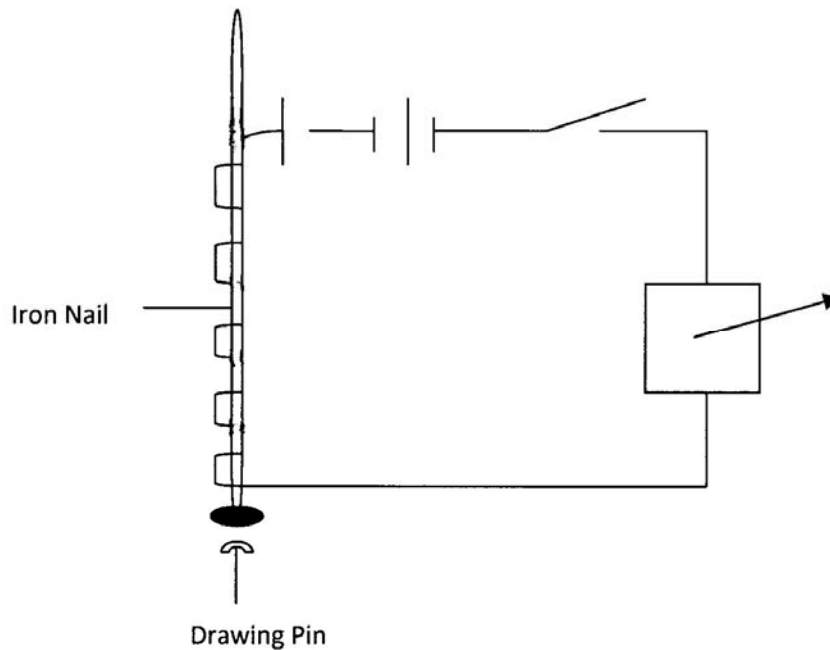

(i) Give two ways in which the strength of the electromagnet could be increased. (2 marks)

(ii) Explain briefly how a ferromagnetic material is magnetised by the single touch methods. (6 marks)

(iii) State the disadvantages if the method in (ii) above. (2 marks)

8. (a)

(i) State the laws of refraction. (2 marks)

- (ii) Complete the diagram to show the formation of a shadow on the screen.

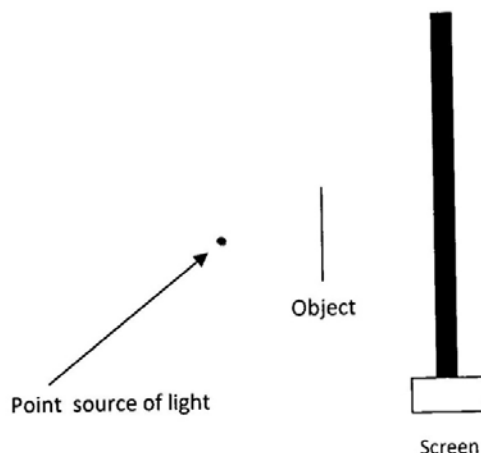

- (iii) How would the shadow be different if an extended source of light had been used? [3 marks]

(b) (i) Draw a well labelled diagram of the human eye, stating his function of each part. (6 marks)

(ii) Name the two eye defects of the human eye, stating how each of them is corrected. (2 marks)

(c) An object is put at a distance of 20cm in front of a converging mirror of focal length of 6cm. calculate the image size and state the nature of the image formed. (2 marks)

9. (a) Define the following:

- (i) Heat capacity. (1 mark)
(ii) Specific heat capacity. (2 marks)
(iii) Specific latent heat of fusion. (2 marks)

(b) Calculate the specific heat capacity of ice given at 420J is used to raise the temperature of 50 g of ice from -10°C to -5°C . (4 marks)

(c)(i) State four properties of a good thermometric liquid. (4 marks)

(ii) Describe how the lower and upper fixed points of a thermometer are obtained by a simple experiment. (4 marks)

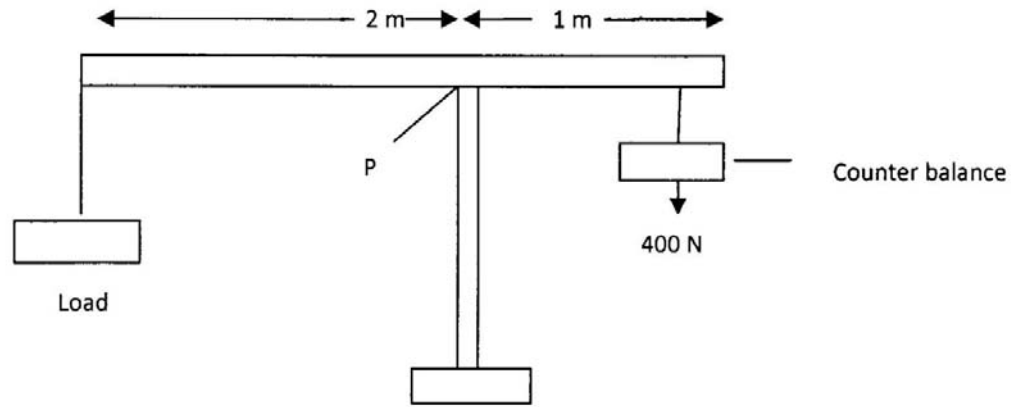

d) The diagram above shows a simple crane. The counterbalance can move left or right but not past pivot P.

- i. Calculate the maximum point of the counterbalance about the pivot P. [4 marks]
- ii. Calculate the maximum load that the crane can lift at the position shown. [4 marks]

THE END



Republic of South Sudan
Ministry of General Education & Instruction
Secretariat of Examinations

044/1
General Science
Paper 1
2 Hours.

SOUTH SUDAN CERTIFICATE OF SECONDARY EDUCATION (S.S.C.S.E)

EXAMINATIONS

NOV/DEC, 2012

GENERAL SCIENCE
PAPER ONE

2 HOURS

NAME (IN CAPITAL LETTERS):

INDEX NUMBER: **Signature:**

INSTRUCTIONS:

1. This paper consists of two sections, A and B. Section A consists of 30 multiple choice questions (30 marks) and section B consists of 6 structured questions (70 marks).
2. All questions are compulsory.
3. Answers to questions in section A are to be written in the boxes provided on the right hand side of each question and those to section B to be written in the spaces provided in the question paper.
4. You will lose marks for untidy work and use additional writing paper besides this.

SECTION A

1. Pressure in liquids acts;

A. in all directions

B. horizontally

C. upwards

D. downwards

2. The following are the mechanisms that affect the internal environment of the body of a mammal **except**;

A. Temperature control

B. Water and ionic control

C. Gaseous exchange and associated breathing mechanisms

D. Balancing the diet

3. Calculate the mass of copper deposited at the cathode by a steady current of 0.25A passed through copper (II) Sulphate solution for 40 minutes.

A. 0.1 g

B. 0.2 g

C. 0.3 g

D. 0.4 g

4. Friction in fluids is known as;

A. Malleability

B. Ductility

C. Viscosity

D. Elasticity

5. Which of the following can spread HIV virus?

A. Shaking hands

B. Insect bites

C. Sharing rooms

D. Body fluid exchange

6. The greatest disadvantage of using carbon based fuels to our environment is;

A. Reducing number of trees surrounding us

B. Reducing amount of rainfalls received in an area

C. Causing air pollution and thus global warming

D. Exposing ground surface leading to soil erosion

7. Like poles of a magnet;

A. attract each other

B. produce a current

C. neutralise each other

D. repel each other

8. The organism that does not carry oxygen using blood in its body is;

A. Fish

B. Cockroach

C. Eagle

D. Snake

9. Which of the following is a deliquescent substance?

A. Concentrated sulphuric acid

B. Sodium hydroxide pellets

C. Copper (II) sulphate

D. Calcium sulphate

10. The instrument for measuring the degree of hotness or coldness of a body is called?

A. Kelvin scale

B. Barometer

C. Manometer

D. Thermometer

11. The following are significant in the detecting and responding of organisms in an environment:

(i) Avoiding unfavourable conditions

(ii) Escape from danger

(iii) Elimination of waste

(iv) Enabling growth to occur

Which of the following are correct statements?

A. (i), (ii) and (iii)

B. (ii), (iii) and (iv)

C. (iii) and (iv)

D. (i), (ii) and (iv)

12. Soap and detergents have harmful effects on aquatic plants and animals because;

- A. They make water surface dirty
- B. Their long carbon chains do not degrade quickly and encourage rapid growth of water plants
- C. The chemicals they have kill aquatic plants and animals
- D. They prevent atmospheric oxygen from entering the water

13. What is the p.d across a resistor of 10Ω when a current of 0.5 A flows through

- A. 10 volts
- B. 15 volts
- C. 10.5 volts
- D. 5 volts

14. Figure 1 below shows a bird's egg. What is the main function of part marked R?

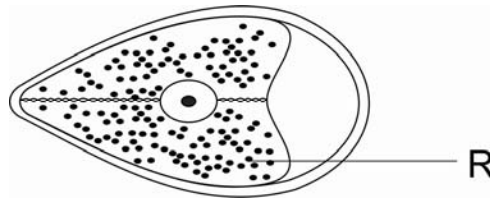

FIGURE 1

- A. Provide food and oxygen
- B. Store excretory product
- C. Protect embryo
- D. Provide food and water

15. Which pair of substances is amorphous carbon only?

- A. Diamond and Wood charcoal
- B. Lamp black and sugar charcoal
- C. Diamond and graphite
- D. Graphite and Lamp black

16. When a ray of light is incident on a rough surface, it is reflected. This type of reflection is known as;

- A. Total internal reflection
- B. Regular reflection
- C. Diffuse reflection
- D. Partial reflection

17. Which of the following are functions of the blood circulatory system in mammals?

- i. Transportation of enzyme
- ii. Transportation of hormone
- iii. Removal of excess amino acids from the body
- iv. Distribution of heat

- A. (iii) and (iv)
- B. (i) and (ii)
- C. (i) and (iii)
- D. (ii) and (iv)

18. In the test for water using cobalt (ii) chloride paper, the colour changes from;

- A. Pink to blue
- B. White to blue
- C. Blue to colourless
- D. Blue to pink

19. What is the water pressure on a submarine 50m below the surface of a sea-water of density 1.04 g/cm^3 ?

A. 520 kpa

B. 250 kpa

C. 50 kpa

D. 600 kpa

20. The sensitive part of the tooth is in;

A. Root

B. Pulp

C. Dentine

D. Enamel

21. In what state does lead II bromide conduct electricity?

A. Aqueous state

B. Solid state

C. Molten state

D. Gaseous state

22. Heat energy from the sun reaches the earth surface by;

A. Conduction

B. Radiation

C. Evaporation

D. Convection

23. Under what conditions will a shoot show the highest transpiration rate?

A. Cold, dry and windy

B. Warm, dry and windy

C. Warm, dry and still air

D. Warm, damp and windy

24. Which one of the following is used as a source of fuel in iron extraction?

A. Calcium oxide

B. Coke (carbon)

C. Carbon monoxide

D. Silica

25. The SI units for length, mass and time are;

A. Metre, grams and seconds

B. Kilometre, grams and seconds

C. Metre, kilogram and seconds

D. Centimetre, grams and minutes

26. The following are characteristics of dicotyledonous plants **except**;

A. Tap root systems

B. Parallel veined leaves

C. Net-veined leaves

D. Fruits

27. Which one of the following reasons explains why diamond is used for making necklaces?

- A. It is a hard substance
- B. It has no free mobile electrons
- C. It is tetrahedral in structure
- D. It has a high refractive index

28. What method of magnetism is shown in figure 2 below?



FIGURE 2

- A. Mutual induction
- B. Electrical method
- C. Triple induction
- D. Magnetic induction

29. Which hormone is likely to be released into the blood stream of an athlete at a beginning of a race?

- A. Anti-diuretic hormone (ADH)
- B. Adrenaline
- C. Thyroxine
- D. Insulin

30. The process through which liver breaks down excess amino acids is called?

A. Detoxification

B. Oxidation

C. Emulsification

D. Deamination

SECTION B

31. (a) State the laws of refraction of light. (2 marks)

- (i)
- (ii)

(b) Mention any two characteristics of images formed by a converging lens. (2 marks)

- (i)
- (ii)

(c) In an experiment to separate component colours through a glass prism, a screen was used to focus the different colours as shown in the figure 3 below.

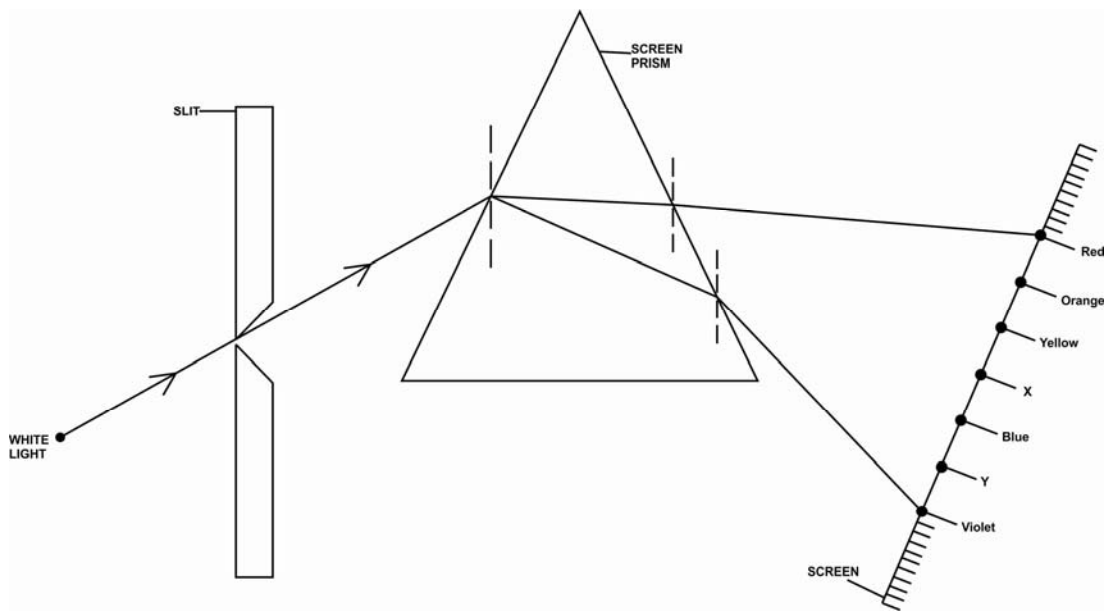

FIGURE 3

(i) Name the colours indicated X and Y. (2 marks)

- X.....
- Y.....

(ii) State the role of the slit in the above experiment? (1 mark)

-
-

(ii) Briefly explain why violet colour is deviated more than red. (3 marks)

.....
.....

32. (a) write the following in full;

(i) HIV.....

.....

(ii) AIDS.....

.....

(b) State the major effect of HIV in the human body

.....
.....

(c) Mention three modes of transmission of HIV in human body.

(i).....

(ii).....

(iii).....

(d) List some four ways in which people with HIV/AIDS infection can prolong their lives by making positive choices to care for their own mental and physical health

(1).....

(2).....

(3).....

(4).....

33. Crude oil consists of a mixture of many hydrocarbons.

(a) (i) What is a hydrocarbon? (2 marks)

.....
.....

(ii) Name any three fractions of crude oil. (3 marks)

1.....

2.....

3.....

(iii) What is the method use for separating crude oil into simpler mixtures? (2 marks)

.....

(b) Explain why it is possible to effect the separation of crude oil by the method in a(iii) above. (2 marks)

.....
.....

(c) State the danger of over burning of the fractions of crude oil to the environment. (1 mark)

.....
.....

34. (a) Define the following terms.

(i) heat (2 marks)

.....
.....

(ii) Vapour pressure (2 marks)

.....
.....

(b) State any two factors which affect the rate of evaporation. (2 marks)

(i).....

(ii).....

(c) A clinical thermometer is made with special features to measure body temperature. Mention two of these features. (2 marks)

(i).....

(ii).....

(c) Give three advantages of using mercury as a liquid in a thermometer. (3 marks)

(i).....

(ii).....

(iii).....

35. (a) What is excretion?

.....
.....
.....

(b) Name two products excreted by each of the following;

(i) Flowering plant

1.....
.....
2.....
.....

(ii) Mammals

1.....
.....
2.....
.....

(c) Figure 4 below shows a cross section of a human kidney. Use it to answer the questions which follow.

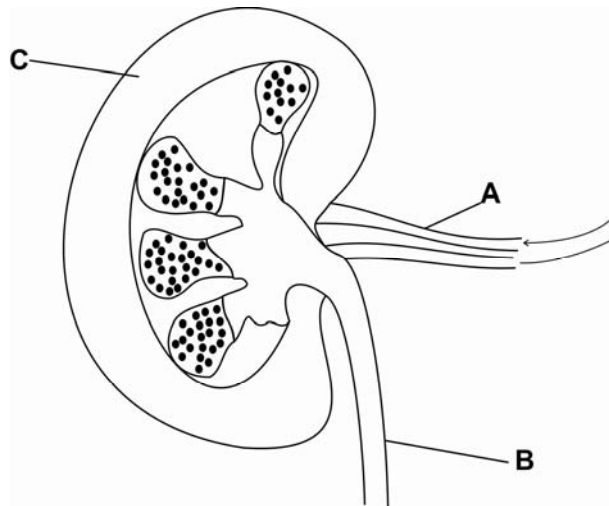

FIGURE 4

(i) Name the parts labelled A, B and C in the figure above

A.....
B.....
C.....

(ii) State the function of part A

.....
.....

(iii) Name the fluid which is transported through B

.....
.....

36 (a) (i) What is meant by an acid salt?

.....
.....

(ii) Give two (2) examples of acid salts

.....
.....

(b) In the preparation of lead II Nitrate, lead II carbonate was added a little at a time to dilute nitric acid in a beaker.

(i) State what was observed

.....
.....

(iii) Write the equation for the reaction

.....
.....

(iv) Name other two salts which can be prepared by the same method

.....
.....

THE END



Republic of South Sudan
Ministry of General Education & Instruction
Secretariat of Examinations

044/2
GENERAL SCIENCE
PAPER TWO
TIME: 2 ½ HOURS.

SOUTH SUDAN CERTIFICATE OF SECONDARY EDUCATION (S.S.C.S.E)

EXAMINATIONS

NOV/DEC, 2012

GENERAL SCIENCE
PAPER TWO

2 ½ HOURS

INSTRUCTIONS:

1. The paper consists of three sections A, B and C.
2. A candidate is required to answer a total of **five** questions, choosing at least one from each of section A, B and C.
3. All questions carry equal marks.
4. Answers to these questions must be written on the answer booklet provided.
5. Unnecessary crossings and illegible handwriting may lead to loss of marks.
6. Where necessary the following constants may be used.
 - i. Acceleration due to gravity, $g = 10\text{ms}^{-2}$
 - ii. Density of water = 1000 kg/m^3
 - iii. Density of paraffin = 800kg/m^3
 - iv. Speed of light = $3.0 \times 10^8 \text{ ms}^{-1}$
 - v. Atomic masses

Cu = 64	Na = 23
C = 12	N = 14
Cl = 35.5	Si = 28
S = 32	Pb = 207
H = 1	Al = 27

SECTION A.

- (a) Food moves through the alimentary canal by a number of processes including ingestion, peristalsis and egestion. Briefly explain each of the three processes mentioned above. (6 marks)

(b) (i) Name the three (3) products of digested food. (3 marks)

(ii) Briefly explain how excess digested food is stored in the body. (5 marks)

(c) Describe the role of the liver in the general body metabolism. (6 marks)
- (a) Figure 1 below shows the structure of a bean's seed.

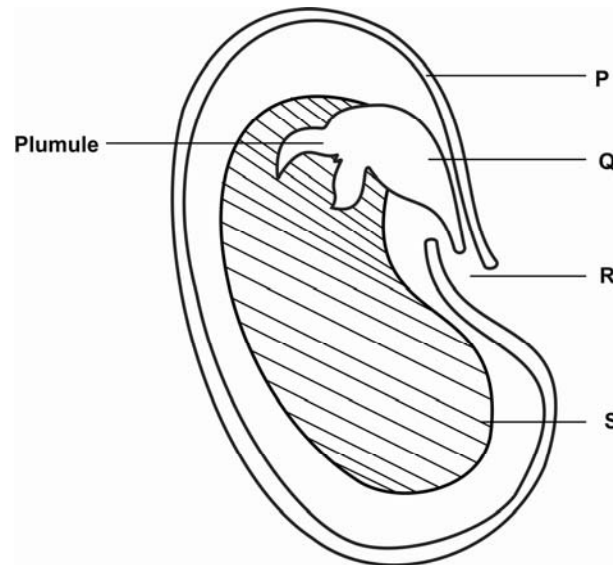

FIGURE 1

- (i) Name the parts labelled P, Q, R and S. (4 marks)

(ii) Explain the use of the part labelled S during germination. (2 marks)
- (b) List the constituents of soil. (6 marks)

(c) Briefly explain six (6) causes of soil erosion. (6 marks)

(d) What is meant by the term 'crop rotation'? (2 marks)

3. (a) Differentiate between HIV and aids. (4 marks)
- (b) Explain at least four ways in which the HIV virus can be transmitted from one person to another. (4 marks)
- (c) Explain six (6) signs and symptoms of HIV/AIDS. (6 marks)
- (c) Mention and briefly explain three (3) cultural practices which increase the spread of HIV/AIDS in your society. (3 marks)
- (d) One of the myths about HIV/AIDS reads 'HIV/AIDS is for the rich'. Outline 3 other myths about HIV/AIDS in your community. (3 marks)

SECTION B

- 4 (a) State two (2) ores of iron. (4 marks)
- (b) Explain how iron III oxide is formed from one of the ores name in 4 (a) above. (5 marks)
- (c) During the extraction of iron in the blast furnace, limestone is used. Explain what happens to the limestone and the impurity in the ore. (5 marks)
- (d) (i) State two (2) properties of iron. (2 marks)
- (iii) Name one (1) alloy of iron and state its use. (2 marks)
- (e) Mention any two metals which are below iron in the reactivity series. (2 marks)
- (5) (a) State any three (3) different forms of carbon. (3 marks)
- (b) Explain any three (3) uses of carbon. (3 marks)
- (c) Explain what is observed when a coke (carbon) is burnt in;
- (i) plenty of air (3 marks)
- (ii) low supply of air. (3 marks)
- (d) (i) Briefly explain two (2) processes through which carbondioxide is added to the atmosphere. (4 marks)

- (ii) Briefly explain two (2) processes through which carbon dioxide is removed from the atmosphere. (4 marks)
- (6) (a) Explain the formation of crude oil and natural gas. (3 marks)
- (b) State the products formed in the compartments of fractional distillation of crude oil. (5 marks)
- (c) Petrol is made from gas oil by cracking process. Using equations, briefly explain the cracking process. (4 marks)
- (d) (i) What is a detergent? (1 mark)
- (ii) State the two kinds of detergents (2 marks)
- (iii) Briefly explain how detergents clean. (5 marks)

SECTION C

7. (a) (i) What is meant by Refractive Index of a medium? (1 mark)
- (ii) Briefly explain why a straight stick placed in a cup full of water appears to be bent. (4 marks)
- (b) State the characteristics of an image formed by a converging lens for an object placed:
- (i) at the principal focus, F. (2 marks)
- (ii) Between the principal focus, F and the centre of curvature, 2F. (3 marks)
- (c) Describe an experiment to determine the focal length of a convex lens. (5 marks)
- (d) Define the term 'magnification' as used in optics. (1 mark)
- (e) An object is 20cm from a converging lens whose focal length is 10cm. Find
- (i) the distance of the image formed from the lens. (3 marks)
- (ii) the magnification of the object. (1 mark)
- (8) (a) (i) state the Ohm's law. (2 marks)
- (ii) State a condition under which Ohm's law is obeyed. (1 mark)

(b) Figure 2 below shows the graph of current (I) against potential difference (V) in a circuit:

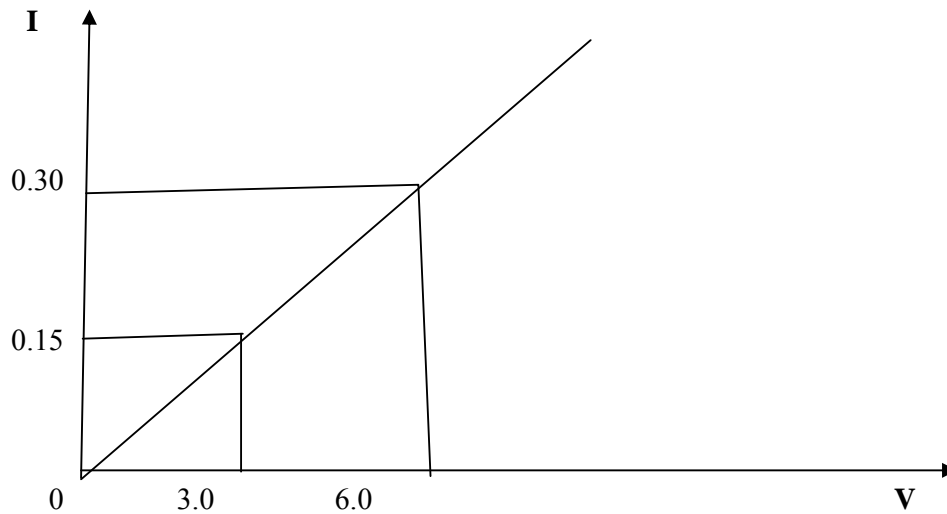
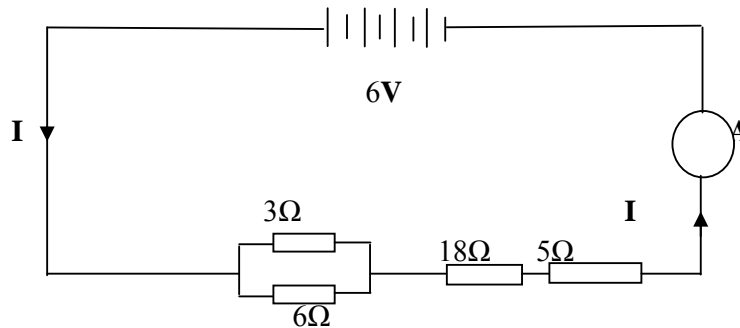

Fig. 2

- (i) Find the gradient of the graph. (2 marks)
- (ii) What does the gradient of the graph represent? (1 mark)
- (iii) Four batteries, four resistors and an ammeter (A) are connected as shown below.



Find the current flowing through the ammeter (A) in the circuit above. (3 marks)

- (c) (i) A wire of resistance 25 ohms is to be used to make a heating coil. How much power will the coil have if a current of 12.5 amperes is used? (3 marks)
- (ii) What would be the cost of running the heater in C (i) above for 3 hours if a kilowatt costs 0.35 SSP? (2 marks)
- (iii) Briefly describe how a d.c motor works. (6 marks)

- (9) (a) (i) Define the term 'frictional force'. (1 mark)
- (ii) State two (2) advantages and two (2) disadvantages of friction. (4 marks)
- (iii) Mention two ways of reducing friction. (2 marks)
- (b) Briefly explain how heat is transferred through solids. (3 marks)
- (c) Describe an experiment to demonstrate expansion of liquids. (3 marks)
- (d) Briefly explain how a thermostat works. (3 marks)
- (e) Explain the following terms related to heat transfer;
- (i) Convection (2 marks)
- (ii) Radiation (2 marks)

THE END



**GOVERNMENT OF SOUTHERN SUDAN
MINISTRY OF EDUCATION
EXAMINATIONS SECRETARIAT**



**SOUTHERN SUDAN CERTIFICATE OF SECONDARY EDUCATION (S.S.C.S.E)
EXAMINATIONS**

Nov./Dec. 2010

**045/1 AGRICULTURE
PAPER ONE
2 HOURS**

NAME (CAPITAL LETTERS):

INDEX NUMBER **SIGNATURE**.....

INSTRUCTIONS

Read these instructions carefully before attempting the questions.

1. This paper consists of 30 multiple choice questions and 5 structured questions, all compulsory (80 marks).
2. Answers to the multiple choice questions must be written in the boxes provided on the right hand side corresponding to each question; and that of the structured questions in the spaces provided on the question paper.
3. No extra sheet of papers shall be provided.

FOR EXAMINERS USE ONLY		
	EXAMINER	TEAM LEADER
SECTION A		
SECTION B		
TOTAL MARKS		

1. The following three species are suitable for agro forestry except.

- A. Eucalyptus
- B. Teak
- C. Albizia
- D. Leucaena

2. Which one of the following is the normal range of body temperature for cattle?

- A. 38.5°C - 40°C
- B. 37.5°C - 39.5°C
- C. 35.5°C - 40.5°C
- D. 38°C - 40°C

3. The process of transferring people from densely populated areas to sparsely populated areas is called

- A. Immigration.
- B. Migration.
- C. Settlement.
- D. Resettlement.

4. The following are associated with land reclamation except

- A. Deforestation.
- B. Desertification.
- C. Irrigation.
- D. Afforestation.

5. Which of the following is **not** classified as a risk in farming?

- A. Price fluctuation.
- B. Farmers health.
- C. Pest and disease outbreak.
- D. Weather changes.

6. Hot water treatment is given to banana suckers before planting in order to

- A. stimulate root development.
- B. control banana weevils.
- C. control banana nematodes.
- D. encourage the development of fresh suckers.

7. Cassava mosaic is caused by

- A. bacteria.
- B. virus.
- C. fungus.
- D. insects.

8. Which one of the following livestock equipments is used for testing for mastitis?

- A. Drenching gun.
- B. Strip cup.
- C. Syringe.
- D. Strainer element.

9. Which one of the following is the difference between cheese and ghee?

- A. Cheese is a solid while ghee is a liquid at room temperature.
- B. Cheese is made from whole milk while ghee is made from butter.
- C. Cheese is obtained from pasteurised milk while ghee is made from unpasteurized milk.
- D. Cheese has a lower human nutritive value than ghee.

10. In ruminants, the digestion of carbohydrates begins in the

- A. abomasum.
- B. mouth.
- C. Rumen.
- D. Reticulum.

11. In a production function the marginal product is zero at a point when

- A. the additional input does not produce any more additional outputs.
- B. additional input to produces more outputs.
- C. additional input produces negative returns.
- D. additional input declines.

12. Which one of the following may be used to raise the pH of the soil?

- A. Sulphate of ammonia.
- B. Lime.
- C. N P K.
- D. Farm yard manure.

13. Which one of the following soil conservation measures may be used effectively to control sheet erosion?

- A. Bench terracing.
- B. Crop rotation.
- C. Contour ploughing.
- D. Mulching.

14. The following factors influence the supply of a commodity in the market except.

- A. Price of related goods.
- B. Number of sellers in the market.
- C. Number of buyers in the market.
- D. The price of the commodity.

15. Which one of the following is the best site for a fish pond?

- A. Where water flows gently from the source.
- B. Where the land is flat and swampy.
- C. Where the soils are sandy.
- D. Near a lake.

16. In a business transaction, an invoice is

- A. a document issued when goods are delivered on cash payment.
- B. a request to a firm to supply specified goods.
- C. a record kept by the seller to track the goods sold off.
- D. a document issued on goods sold on credit.

17. The following are the reasons for treating farm water except

- A. to destroy pathogens.
- B. to increase its mineral content.
- C. to remove unacceptable smells.
- D. to remove sediments.

18. Which one of the following features is not true of vegetative propagation crops?

- A. They are less affected by pests and diseases than their parents.
- B. Their yields are similar to that of their parents.
- C. They mature earlier than those propagated by seed.
- D. They are less drought resistant than those by seeding.

19. Continuous cultivation of land is not recommended because it destroys the soil.

- A. profile.
- B. structure.
- C. texture.
- D. drainage.

20. Which one of the following is not an advantage of the deep liter system of keeping poultry?

- A. More birds can be kept in a given area.
- B. Vices can be easily controlled.
- C. Birds are protected from bad weather conditions.
- D. It is easy to monitor the performance of the birds.

21. Milk let down refers to

- A. the removal of milk from the milk secretory cells to the lower part of the udder.
- B. the removal of milk through the teats into a container.
- C. interruption on the milking process by the secretion of adrenergetic hormone.
- D. failure of milk secretion because of inadequate production of the oxytocin hormone.

22. The Gross margins for various enterprises in the farm can be determined by

- A. Subtracting the total variable costs from the total revenue.
- B. Subtracting the total fixed costs from the total revenue.
- C. Subtracting the total costs from the total revenue.
- D. Subtracting revenue from one enterprise from the total revenue of the farm.

23. Which one of the following is a remedy for price fluctuations of agricultural products?

- A. Trade liberalization.
- B. Diversification.
- C. Specialization.
- D. Large scale production.

24. In cattle a disease that causes sudden death with a blown up stomach, and blood coming out of the body openings is likely to be

- A. Brucellosis.
- B. Contagious Bovine pleuro Pneumonia.
- C. Anthrax.
- D. Tuberculosis.

25. Which one of the following statements is true of mitosis?

- A. The number of chromosomes remains the same in each cell after cell division.
- B. The number of chromosomes is halved in each cell after cell division.
- C. It occurs during the production of reproductive cells.
- D. Mitosis results in the production of four daughter cells.

26. Which one of the following is the correct distinction between hybrid maize and composite maize seeds?

- A. Hybrid maize seeds are smaller than composite maize seeds.
- B. Fresh hybrid maize seeds have to be planted every growing season while composite maize seeds can be taken from the previous crop.
- C. Hybrid maize seeds generally yield lower than composite maize seeds.
- D. Hybrid maize is more tolerant to drought than composite maize.

27. A burdizzo is an implement used for

- A. Putting identification marks on cattle.
- B. Administering oral drugs to cattle.
- C. Castrating bulls.
- D. Restraining animals.

28. Which one of the following statements is true of predators?

- A. They attack more than one host.
- B. They live inside their hosts.
- C. They cause diseases that kill their host.
- D. They are well adapted to the host environment.

29. Opportunity cost may be defined as of the cost of establishing as:

- A. The cost of establishing a new business.
- B. The value of resources given up as a result of choosing its next best alternative.
- C. Hidden costs in a production process.
- D. Costs must be met irrespective of the level of production.

30. A mould board plough is the most suitable implement to use in.

- A. hard soils with many stores.
- B. Heavy soils.
- C. Sandy soils.
- D. Swampy soils.

SECTION B

31. (a) Outline the importance of forests.

5 marks

- (i) _____
- (ii) _____
- (iii) _____
- (iv) _____
- (v) _____

(b) Suggest 5 indicators to show that a natural pasture is in need of improvement.

5 marks

- (i) _____
- (ii) _____
- (iii) _____
- (iv) _____
- (v) _____

32. (a) Give 5 precautions to be taken to ensure effectiveness of herbicide application. **5 marks**

- (i) _____
- (ii) _____
- (iii) _____
- (iv) _____
- (v) _____

(b) Give 4 reasons why weeds often out compete planted crops. **5 marks**

- (i) _____
- (ii) _____
- (iii) _____
- (iv) _____

33. (a) Outline 5 ways in which infectious diseases can spread within a livestock herd. **5 marks**

- (i) _____
- (ii) _____
- (iii) _____
- (iv) _____
- (v) _____

(b) State 5 abnormalities that occur in eggs of poultry. **5 marks**

- (i) _____
- (ii) _____
- (iii) _____
- (iv) _____
- (v) _____

34. (a) Give 5 limitations of using live fencing on farmland. 5 marks

(i) _____

(ii) _____

(iii) _____

(iv) _____

(v) _____

(b) Outline 5 qualities of a good animal. 5 marks

(i) _____

(ii) _____

(iii) _____

(iv) _____

(v) _____

35. (a) Give 5 measures that could be taken to reduce the effect of price fluctuations on the farmer. 5 marks

(i) _____

(ii) _____

(iii) _____

(iv) _____

(v) _____

(b) State 5 sources of agricultural credit in Southern Sudan. 5 marks

(i) _____

(ii) _____

(iii) _____

(iv) _____

(v) _____

END



Republic of South Sudan
Ministry of General Education & Instruction
Secretariat of Examinations

045/1
AGRICULTURE
PAPER ONE
2 hours

SOUTH SUDAN CERTIFICATE OF SECONDARY EDUCATION(SSCES) EXAMINATIONS

Nov/Dec, 2011

AGRICULTURE
PAPER ONE

TIME: 2 HOURS

INSTRUCTIONS

Read the instructions carefully before answering any question

1. *This paper consists of 30 multiple choice questions and 5 structured questions. All are compulsory.*
2. *Answers to the multiple choice questions must be written in the boxes provided on the right hand side corresponding to each question; and that of the structured questions in the spaces provided on the question paper.*
3. *No extra sheets of papers shall be provided.*

FOR EXAMINERS USE ONLY		
	EXAMINER	TEAM LEADER
SECTION A		
SECTION B		
TOTAL MARKS		

© Ministry of General Education & Instruction, SSCSE, 2011

SECTION A

1. Which of the following part of ruminant digestion is responsible for breaking food particles into small bits?
- A. Abomasum.
 - B. Rumen.
 - C. Reticulum.
 - D. Omasum.
-
2. The control of rhizomatous weeds is best achieved by use of
- A. Spraying with non selective herbicides.
 - B. Digging up the rhizomes.
 - C. Using systemic herbicides.
 - D. Burning the weed.
-
3. Soil structure refers to
- A. The relative amounts of the different soil particle sizes.
 - B. The binding of soil particles.
 - C. How resistant soil is to soil erosion.
 - D. The amount of soil particles compared to other components in the soil.
-
4. The following factors encourage cannibalism in poultry
- A. Amount of light in the poultry house.
 - B. Amount of space per bird in the poultry house.
 - C. Absence of exercise in the poultry house.
 - D. The breed of poultry.
-
5. Overhead irrigation is preferred in areas with
- A. Irregular landscape.
 - B. Gentle slopes.
 - C. Irrigation water is scarce.
 - D. Soils are heavy.
-
6. Administration of liquid drugs through the mouth is best done by using
- A. Hypodermic needle.
 - B. Drenching gun.
 - C. Stir-up pump.
 - D. Bolus gun.
-

7. Nitrogen fertilizers are not normally applied to a grass-legume mixed pasture because

- A. Grass may grow to suppress the legumes.
- B. Legumes fix sufficient nitrogen for the pasture.
- C. Nitrogen may become toxic to the legumes.
- D. Nitrogen suppresses the uptake of essential nutrients for the pasture.

8. Poultry manure is preferred to other types of manure because it

- A. is cheap and easily available.
- B. is easy to apply.
- C. has higher Nitrogen content.
- D. contains no harmful bacteria.

9. The term opportunity cost refers to

- A. Revenue forgone as a result of producing one product in the place of a competitive product.
- B. The cost of producing a product compared to the revenue got from it.
- C. Unforeseen costs resulting from the production of a new commodity.
- D. Additional revenue as a result of producing one product in the place of another product.

10. Which of the following best describes cross breeding?

- A. Crossing of two unbred lines.
- B. Mating of off springs from different families.
- C. Crossing of animals within the same breed.
- D. Mating animals with different characteristics

11. Which one of the following statements is true of meiosis?

- A. The number of chromosomes remain the same in each cell after cell division.
- B. The number of chromosomes is halved in each cell after cell division.
- C. It occurs in somatic cells only.
- D. It results in the production of two identical daughter cells.

12. Which one of the following is true of the diesel engine?

- A. They have a carburettor.
- B. There is a spark plug.
- C. They have injector pumps.
- D. Air and fuel mixture is fed into the cylinder for combustion.

13. The pH of soil may be lowered by application of.

- A. Lime.
- B. Farm yard manure.
- C. Sulphate of Ammonia.
- D. Single superphosphate.

14. The following are advantage of trickle irrigation except.

- A. Loss of water through evaporation is minimized.
- B. Weed growth is discouraged.
- C. There are more chances of salt accumulation with root zone.
- D. It requires little attention after installation.

15. In ruminant, digestion of protein begins in the.

- A. Rumen.
- B. Omasum.
- C. Reticulum.
- D. Abomasums.

16. During the induction stroke of a 4 stroke engine, the piston moves,

- A. downwards and both valves are closed.
- B. upwards and the outlet valve is open.
- C. downwards and the inlet valve is open.
- D. upwards and both valves are closed.

17. The late blight of tomatoes is caused by

- A. virus.
- B. bacteria.
- C. too much rain.
- D. fungus.

18. The following is true of parasites except

- A. They require more than one host.
- B. They are host specific.
- C. They are well adapted to the host environment.
- D. Their life cycle is longer than that of their host.

19. Which one of the following determines the price of a commodity in the open market?

- A. The cost of production.
- B. Supply and demand.
- C. Number of buyers in the market.
- D. Cost of transport.

20. Which one of the following is true of supplementary products?

- A. Increase in the production of one does not affect the production of the other.
- B. Production of one product decreases by the production of the other.
- C. Increase in the production of one automatically increases the production of the other.
- D. They require the same resources.

21. The shell of an egg is produced in the

- A. Magnum.
- B. Uterus.
- C. Isthmus.
- D. Infundibulum.

22. Anthrax is caused by

- A. Bacteria.
- B. Virus.
- C. Protozoan.
- D. Nematodes.

23. A cow that shows high fever, excessive production of saliva, dullness and swelling of lymph glands is likely to be suffering from

- A. Brucellosis.
- B. Mastitis.
- C. Rinderpest.
- D. East Coast fever.

24. The following are advantages of rotovators except
- A. They break the soil hard pan.
 - B. Prepare a fine filth ready for planting in one operation .
 - C. Incorporate surface trash into the soil.
 - D. Break up large clods.
25. Synthetic crop varieties are preferred for most farmers in the Sudan because
- A. They produce higher yields than other varieties.
 - B. They are less affected by pests and diseases.
 - C. The are more drought resistant.
 - D. Seeds produced by farmers can be replanted.
26. Stocking rate refers to the number of
- A. animals per unit of pasture.
 - B. days a pasture is rested before regrazing.
 - C. paddocks available for grazing.
 - D. animals on the farm.
27. Which one of the following hormones suppresses milk let-down in lactating cows?
- A. Oestrogen.
 - B. Prolactin.
 - C. Adrenalin.
 - D. Oxytocin.
28. In production, the cost of feed is
- A. fixed cost.
 - B. marginal cost.
 - C. implicit cost.
 - D. variable cost.
29. Which one of the following is classified as an uncertainty in a production process?
- A. Price fluctuation.
 - B. Weather changes.
 - C. Pest and Disease outbreak.
 - D. Accidents to Employees.
30. Small seeds are planted at a shallower depth because
- A. they need some light in order to germinate.
 - B. their food reserves may be exhausted before germination.
 - C. plant nutrients are concentrated on the soil surface.
 - D. it is easier to monitor their viability at a shallow depth.

SECTION B

31 (a) Give 5 benefits of drainage in agricultural production

- (i) _____
- (ii) _____
- (iii) _____
- (iv) _____
- (v) _____

(b) State 2 advantages and 3 disadvantages of sub-surface drainage

Advantages

- (i) _____
- (ii) _____

Disadvantages

- (i) _____
- (ii) _____
- (iii) _____

32 (a) Give 5 reasons for tilling land before planting

- (i) _____
- (ii) _____
- (iii) _____
- (iv) _____
- (v) _____

(b) State 5 characteristics of a good site for the construction of nursery seedbed

(i) _____

(ii) _____

(iii) _____

(iv) _____

(v) _____

33 (a) Distinguish between Farmyard manure and compost manure.

(b) Give 5 contribution of organic matter in soil productivity.

(i) _____

(ii) _____

(iii) _____

(iv) _____

(v) _____

34. (a) Give 3 advantages and 2 disadvantages of the deep litter system of poultry rearing.

Advantages

(i) _____

(ii) _____

(iii) _____

Disadvantages

(i) _____

(ii) _____

(b) State 5 methods of preventing vices in poultry houses

- (i) _____
- (ii) _____
- (iii) _____
- (iv) _____
- (v) _____

35 (a) State 5 functions of marketing.

- (i) _____
- (ii) _____
- (iii) _____
- (iv) _____
- (v) _____

(b) Give 5 characteristics of perfect competition in a market situation.

- (i) _____
- (ii) _____
- (iii) _____
- (iv) _____
- (v) _____

END



Republic of South Sudan
Ministry of General Education & Instruction
Secretariat of Examinations

045/2
AGRICULTURE
PAPER TWO
3 hours

SOUTH SUDAN CERTIFICATE OF SECONDARY EDUCATION(SSCES) EXAMINATIONS

Nov/Dec, 2011

AGRICULTURE
PAPER TWO

TIME: 3 HOURS

INSTRUCTIONS

Read the instructions carefully before answering any question

1. *Write your name, index number clearly in capital letters and sign on ALL answer booklets used.*
2. *This paper consists of five(5) Sections A, B, C, D and E*
3. *Answer question 1 in Section A and any four questions selecting one from each of the sections B,C, D and E.*

FOR EXAMINERS USE ONLY		
	EXAMINER	TEAM LEADER
SECTION A		
SECTION B		
SECTION C		
SECTION D		
SECTION E		
TOTAL MARKS		

© Ministry of General Education & Instruction, SSCSE, 2011

SECTION A:

1. The table below shows the response of maize yield to fertilizer application.

Fertilizer (bags)	Yield (Total Product)	Marginal Product
1	3	
2	7	
3	12	
4	16	
5	19	
6	21	
7	22	
8	22	
9	21	
10	18	
11	13	

- Complete the table by calculating the Marginal product.
- Draw a graph to show the relationship between maize yield and the amount of fertilizer applied.
- Explain the shape of your graph.
- Mark and name the most profitable zone of production on the graph.
- Give a reason for your answer in (c) above.
- Explain the changes in value of the Marginal Product you calculated in (a) above.

SECTION B:

CROP PRODUCTION

- Explain the value of Horticulture in the economy of South Sudan.
 - Suggest how the production of horticultural crops can be improved in South Sudan.
- Explain with reasons the cultural practices involved in the growing of a tomato crop.

SECTION C:

ANIMAL PRODUCTION

4. (a) Why is the keeping of indigenous cattle breeds still preferred by most cattle keepers in South Sudan.
(b) Suggest ways in which the livestock industry in South Sudan could be improved.
5. (a) Give reasons why an animal must be fed.
(b) Explain how you would feed a calf from birth to weaning.

SECTION D:

AGRICULTURAL MECHANIZATION

6. Using appropriate illustrations describe the functioning of a 4-stroke petrol engine.
7. (a) Explain the factors to consider while constructing an animal house on the farm.
(b) Give reasons for the popularity of wood as construction material.

SECTION E:

AGRICULTURAL ECONOMICS

8. (a) Using appropriate illustrations, explain how price is determined in a free market.
(b) What are the factors that affect?
 - (i) the price of a commodity.
 - (ii) the demand of a commodity.
9. (a) Explain the problems involved in the marketing of agricultural products.
(b) How can farmers in South Sudan benefit from co-operatives?

END



**Republic of South Sudan
Ministry of General Education & Instruction
Secretariat of Examinations**

045/1
AGRICULTURE
PAPER ONE
1¹/₂ hours

SOUTH SUDAN CERTIFICATE OF SECONDARY EDUCATION (SSCES) EXAMINATIONS

Nov/Dec, 2012

045/1

AGRICULTURE

PAPER ONE

TIME: 1¹/₂ HOURS

INSTRUCTIONS

Read the instructions carefully before answering any question

- 1. This paper consists of 30 multiple choice questions and 5 structured questions. All are compulsory.*
- 2. Answers to the multiple choice questions must be written in the boxes provided on the right hand side corresponding to each question; and that of the structured questions in the spaces provided on the question paper.*
- 3. No extra sheets of papers shall be provided.*

FOR EXAMINERS USE ONLY		
	EXAMINER	TEAM LEADER
SECTION A		
SECTION B		
TOTAL MARKS		

SECTION A

1. Which of the following is **not** a branch of agriculture?

- a) Crop production
- b) Economics
- c) Agricultural mechanization and Engineering
- d) Animal production

2. The following are problems facing agriculture in South Sudan **except**

- a) Tools
- b) Climate
- c) Transport
- d) Land

3. The system of farming where short term crops are grown is known as

- a) Arable farming
- b) Plantation
- c) Small scale farming
- d) Mixed farming

4. Which of the following is a biotic factor?

- a) Pests
- b) Market
- c) Wind
- d) Soil PH

5. The process by which soil loses its fertility in to the air is known as

- a) Leaching
- b) Burning
- c) Volatilization
- d) Soil Erosion

6. Which pair of words suits the best methods of conserving soil and water in a hilly area

- a) Contour farming and terrace
- b) Contour farming and bunds
- c) Terrace and bunds
- d) Mulching and terrace

7. The main cause of physical weathering is

- a) Contraction and farming
- b) Digging and expansion
- c) Contraction and expansion
- d) Digging and contraction

8. The liquid substance in the center of a spirit level is known as

- a) Water
- b) Oil
- c) Mercury
- d) Alcohol

9. Which of the following is **not** a primary cultivation equipment?

- a) Disc plough
- b) Disc Harrow
- c) Rotary cultivation
- d) Ox mouldboard plough

10. The most appropriate depth of planting maize and bean seeds is

- a) 2.5 cm – 10 cm
- b) 1.5 cm – 2.5 cm
- c) 3.5 cm – 4.5 cm
- d) 0.5 cm – 1.5 cm

11. Which of the following crops is a leguminous plant?

- a) Oats
- b) Simsim
- c) Cow peas
- d) Tomatoes

12. The most expensive method of controlling pests and diseases in the farm is known as

- a) Chemical method
- b) Physical method
- c) Biological method
- d) Cultural method

13. Which of the following is an advantage of weeds?

- a) Competition with crops
- b) Poisonous to both man and animals
- c) Source of food to both man and animals
- d) Reduce crop yields

14. What is the meaning of the word 'stock rate'?

- a) Number of animal per land
- b) Number of animal per capital
- c) Number of animal per labour
- d) Number of animal per unit area

15. The process by which a farmer introduces a new variety of crop that takes short time to mature is called?

- a) Selection
- b) Hybridization
- c) Cross breeding
- d) In breeding

16. Which of the following practices aims at reducing excess plant population in the field?

- a) Rogueing
- b) Earthing
- c) Gapping
- d) Pruning

17. Which one of the following is a remarkable difference between the two and four stroke engine?

- a) Two stroke engine has valves
- b) Four stroke engine has no valves
- c) The four stroke events are completed in one cycle for a four stroke engine
- d) Two stroke engine are used for light jobs/works

18. The sharp edge used for cutting the furrow slice found in both tractor and ox-drawn implements is known as

- a) Beam
- b) Share
- c) Frog
- d) Hake

19. The main reason for water treatment is to

- a) Add flavor
- b) Destroy pathogen
- c) Add germs
- d) Add smell

20. The two main methods of drainage are

- a) Surface and over head
- b) Sub-surface and over head
- c) Surface and sub-surface
- d) Channel and over head

21. The type of irrigation where water is supplied through pipes mounted with sprinklers is called?

- a) Surface irrigation
- b) Sub-surface irrigation
- c) Drip irrigation
- d) Over head irrigation

22. The elements below can be used customary to guarantee the safety of water **except**?

- a) Chlorine
- b) Chlorinated lime
- c) Sodium hypochloride
- d) Copper

23. Which one of the following is not a factor of production?

- a) Land
- b) Management
- c) Labour
- d) Transport

24. Which of the following affects efficiency standards?

- a) Prices
- b) Capital
- c) Input
- d) Output

25. Which one is true about the law of demand and supply?

- a) Increase in supply causes decline in price
- b) Increase demand causes decline in price
- c) Increase in supply causes increase in price
- d) Increase in demand causes no price

26. The following are essential methods of land reform **except**

- a) Improving land tenure legislation
- b) Land fragmentation
- c) Consolidation of land holdings
- d) Tenancy reform

27. Which of the following is a source of capital?

- a) Labour
- b) Trade unions
- c) Bank
- d) Credit

28. The book of account that shows the order of record of accounting transaction is referred to as

- a) Cash book
- b) Ledger
- c) Journal
- d) Inventory

29. Which of the following is not a nitrogenous fertilizer?

- a) CAN
- b) ASN
- c) Urea
- d) SSP

30. The term aquaculture means

- a) Fish farming
- b) Bee keeping
- c) White ants keeping
- d) Flies keeping

SECTION B

31. Mention five qualities of a good stock person.

- (i)
- (ii)
- (iii)
- (iv)
- (v)

32. What are the advantages and disadvantages of a forest to a man?

(A) Advantages

- (i)
- (ii)
- (iii)
- (iv)
- (v)
- (vi)

(B) Disadvantages

- (i)
- (ii)
- (iii)
- (iv)

33. (a) State the common problems associated with storage of farm products

- (i)
- (ii)
- (iii)
- (iv)
- (v)

(b) What are the desirable features of a store?

- (i)

- (ii)
- (iii)
- (iv)
- (v)

34. (a) Identify the problems hindering adaptation of mechanization in Africa

- (i)
- (ii)
- (iii)
- (iv)
- (v)

(b) Suggest solutions to the problems mentioned in 32 (a) above.

- (i)
- (ii)
- (iii)
- (iv)
- (v)

35. Describe five types of record that a farmer can keep in a farm.

- (i)
.....
- (ii)
.....
- (iii)
.....
- (iv)
.....
- (v)
.....

END



Republic of South Sudan
Ministry of General Education & Instruction
Secretariat of Examinations

045/2
AGRICULTURE
PAPER TWO
2 ½ Hours

SOUTH SUDAN CERTIFICATE OF SECONDARY EDUCATION (SSCES) EXAMINATIONS

Nov/Dec, 2012

045/2

**AGRICULTURE
PAPER TWO**

TIME: 2 ½ Hours

INSTRUCTIONS

Read the instructions carefully before answering any question

1. *This paper consists of five(5) Sections A, B, C, D and E*
2. *Answer question 1 in Section A and any four questions selecting one from each of the sections B, C, D and E.*

FOR EXAMINERS USE ONLY		
	EXAMINER	TEAM LEADER
SECTION A		
SECTION B		
SECTION C		
SECTION D		
SECTION E		
TOTAL MARKS		

SECTION A: (COMPULSARY)

1. (a) Explain five (5) differences between organic and inorganic fertilizers (10 Marks)
- (b) Mention and explain ten (10) general methods of applying artificial fertilizers (10 Marks)

SECTION B: (CROP PRODUCTION)

2. (a) Using Groundnuts, Maize, Cotton, Cassava and one fallow period, plan and design a five (05) year's crop rotation programme indicating which crop comes first, second, third, fourth and fifth. (05 Marks)
 - (b) For each crop chosen in first, second, third, fourth and fifth positions, give a reason for your choice. (05 Marks)
 - (c) Explain the importance of crop rotation. (10 Marks)
3. (a) Differentiate between hay and silage. (04 Marks)
 - (b) Describe the procedure of making hay. (04 Marks)
 - (c) What factors influence the quality of hay? (06 Marks)
 - (d) State the limitations faced in making silage in the farm. (06 Marks)

SECTION C: (ANIMAL PRODUCTION)

4. (a) Explain the basic factors that a livestock farmer should consider before mixing animal feeds (10 Marks)
 - (b) A farmer who owns a poultry enterprise has maize containing 16% protein and fish meal containing 86% protein. As a student, help the farmer to compute the proportion of the two ingredients to make a meal of mixture of 45% protein. Use the Pearson's square method and support your procedure or steps with an explanation. (10 Marks)
5. (a) Describe the management practices in keeping of pigs. (10 Marks)
 - (b) What are the problems associated with keeping of pigs. (10 Marks)

Section D: (MECHANIZATION AND ENGINEERING)

6. Describe the sources of farm power that are commonly used by farms. (20 Marks)
7. Describe the methods of agro-forestry tree harvesting (20 marks)

Section E: (AGRICULTURAL ECONOMIES)

8. Define the following terms as applied to farming and give four examples of each.

(i) Risks

(ii) Uncertainties

(06 Marks)

(b) What measures should a farmer adopt to safeguard against risks and uncertainties?

(14 Marks)

9. (a) Explain what is meant by the following;

(i) Balance sheet.

(ii) Profit and loss account. (08 Marks)

(b) Mr. Zachariah is a farmer who practices mixed farming. Help him to prepare a balance sheet using the information below that he has at hand as from 30th June 2012.

Items	Value (SSP)
-Cash at hand	500
-Feed in the store	200
-Debt payable	350
-Cash in the bank	750
-Loan from the bank	650
-Debt receivable	1000
-Prepared expenses	750

-Value of machine	250
-Livestock value	800
-Depreciation of machines	700
-Bank overdraft	300
-Value of buildings	400

(12 Marks)

THE END



Republic of South Sudan
Ministry of General Education & Instruction
Secretariat of Examinations

045/3
AGRICULTURE
PAPER THREE (PRACTICAL)
2 HRS

SOUTH SUDAN CERTIFICATE OF SECONDARY EDUCATION (SSCSE)
EXAMINATIONS
NOV/ DEC 2012
045/3
AGRICULTURE
PAPER THREE (PRACTICAL)
2 HRS

NAME:.....

INDEX NUMBER: **SIGNATURE**

INSTRUCTIONS:

1. Answer **ALL** Questions.
2. Write your answers in the spaces provided.

FOR EXAMINERS USE ONLY			
Q1			
Q2			
Q3			
Q4			
Q5			
TOTAL			

Q1. You are provided with specimens A1, A2 and A3 which are soil samples. Conduct an experiment and enter your results in the spaces provided.

Procedures

- i. Obtain a sample of soil.
- ii. Moisten the sample of soil and squeeze out the water until it acquires a plastic quality.
- iii. Roll the sample between the palms of your hands until it attains a cylindrical shape.
- iv. Try to bend it into a shape of a ring. The degree of success in these operations will tell you something about the soil texture.

a. Observation on analysis of soil during the experiment

A1.....
.....
.....

A2.....
.....
.....

A3.....
.....
.....

b. Classify the soils and write down the identity of each one of them

A1.....

A2.....

A3.....

c. Which one of the soil types is suitable for agricultural production?

.....

D. Explain three characteristics of the soil type mentioned in 1 (c) above.

- i.....
- ii.....
- iii.....

Q2. You are provided with specimens B1, B2, B3, B4 and B5.

a. Examine and identify the specimens

- B1.....
- B2.....
- B3.....
- B4.....
- B5.....

b. State a function of each specimen

- B1.....
- B2.....
- B3.....
- B4.....
- B5.....

c. Identify one defect on each specimen which may limit its efficient use.

- B1.....
- B2.....
- B3.....
- B4.....
- B5.....

d. Explain how the defect on each of the specimen may affect its efficient use.

B1.....

B2.....

B3.....

B4.....

B5.....

(½ mark for each correct answer =10 marks maximum)

Q3 Specimens C1, C2, C3, and C4 are materials that can be used for sugar cane production.

(a) Give one comment in each case on the suitability of each specimen for planting.

C1.....

C2.....

C3.....

C4.....

(b) Identify one of the specimens that can be improved for planting.

.....

(c) Suggest how the specimen mentioned in 3 (b) above can be improved.

.....

(d) Describe how you would plant the specimen in 3(b) above, after improvement.

(i).....

.....

(ii).....

.....

(iii).....

.....

(iv).....
.....

(Each correct answer is 1 mark=10 marks maximum)

Q.4 You are provided with the reproductive system of poultry, examine it carefully and answer the questions that follow

(a) Identify the parts labelled

D1

D2

D3.....

D4

D5

(b)List the main function of each of the parts.

D1

D2

D3.....

D4

D5

Q.5 You are provided with parts of the internal combustion engine labelled E1, E2, E3, E4, E5, E6, E7, E8, E9 and E10. Study carefully and use them to answer the questions that follow.

Fill in the below table with correct information

Specimen	Identity of specimen	Summarize the functions of the specimen
E1		
E2		
E3		
E4		
E5		
E6		
E7		
E8		
E9		
E10		

Each correct answer is ½ marks maximum marks 10 marks

The End